

Principles of Train working and need for signalling

1

Chapter

All over the world Railway transportation is increasingly used, as this mode of transport is more energy efficient and environmentally friendly than road transportation. Trains move on steel rail tracks and wheels of the railway vehicle are also flanged Steel wheels. Hence least friction occurs at the point of contact between the track & wheels.

Therefore trains carry more loads resulting in higher traffic capacity since trains move on specific tracks called rails, their path is to be fully guided and there is no arrangement of steering. Clear of obstruction as available with road transportation, so there is a need to provide control on the movement of trains in the form of Railway signals which indicate to the drivers to stop or move and also the speed at which they can pass a signal.

Since the load carried by the trains and the speed which the trains can attain are high, they need more braking distance before coming to the stop from full speed. Without signal to be available on the route to constantly guide the driver accidents will take place due to collisions.

There are basically two purposes achieved by railway signalling.

1. To safety receive and despatch trains at a station.
2. To control the movements of trains from one station to another after ensuring that the track on which this train will move to reach the next station is free from movement of another train either in the same or opposite direction. This Control is called block working. Preventing the movement from opposite direction is necessary in single line track as movements in both directions will be on the same track.

Apart from meeting the basic requirement of necessary safety in train operation, modern railway signalling plays an important role in determining the capacity of a section .The capacity decides the number of trains that can run on a single day. By proper signalling the capacity can be increased to a considerable extent without resorting to costlier alternatives.

The essential components of railway signalling:

The fixed signals provided by the side of the railway track with indication in the form of colour lights are the actual authority to a driver to get in to the portion of the track beyond the signal. At stations the trains may be received on any one of the platform lines. To take the train to any specific track, points are provided. The purpose of the point on the track is to divert the train from one track to adjacent one. Hence the signal has to be connected to the points in an arrangement called interlocking. This Interlocking arrangement only ensures that a point is correctly set for the particular route or a track and the signal conveys this information to the driver.

Basic Track Structure

- Point & Crossing

Trains run on dedicated line .A line consists of two rails running parallel to each other. This is also called 'Track '. The width of the track is 5'6" in Broad gauge (B.G)

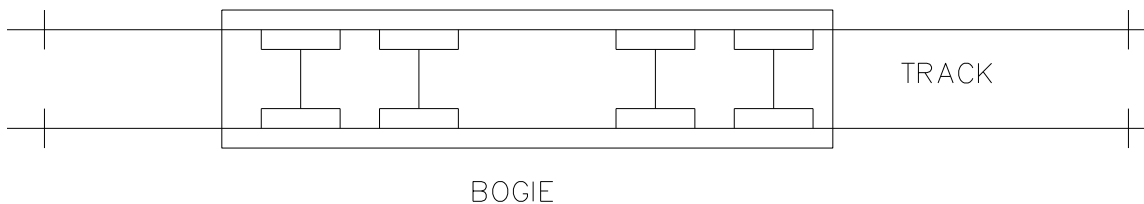

The track is represented in Signalling plans by a single line as shown below.



In station yards there will be more than one track for receiving and dispatching trains.

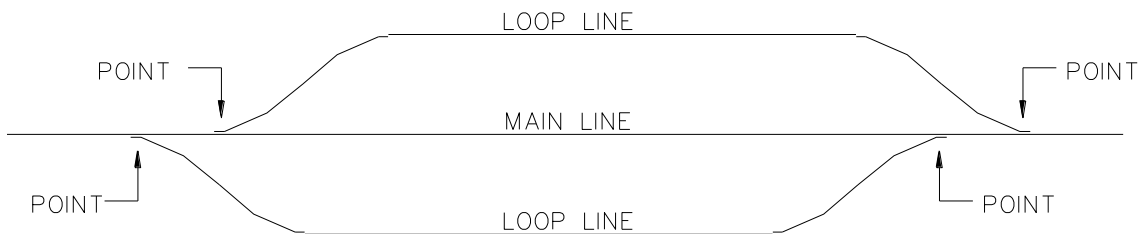

Points are provided to divert the running trains from one track to another. The points have movable switches which can be operated electrically by a **point machine**.

A point can be single-ended point or double-ended point depending on whether the movable switches are provided at one end or two ends of the point,

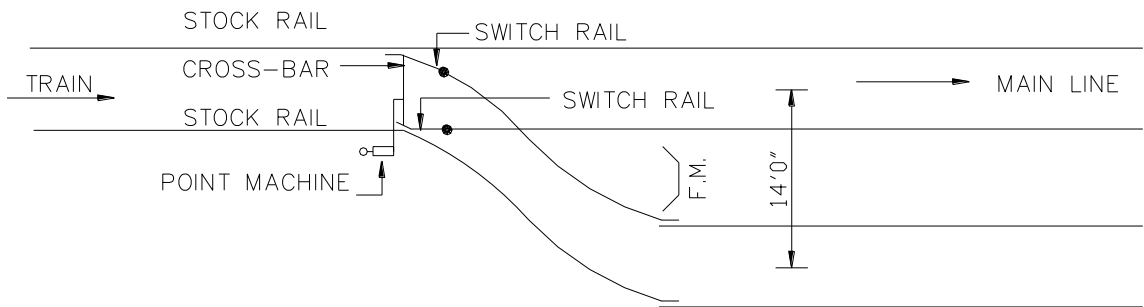
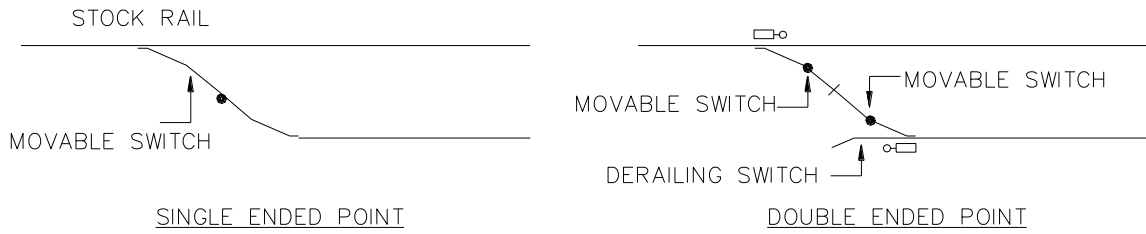

The two switch rails of the point are rigidly connected together by a cross bar so that they can be moved from one position to the other position together by the point machine. If the position of the switches is such that the train is moved on to the main line as shown above, then the point is said to be in its normal (N) position.

If the switch rails are moved to the other position as shown below so that the train is diverted to the loop line, then the point is said to be in its REVERSE (R) position.

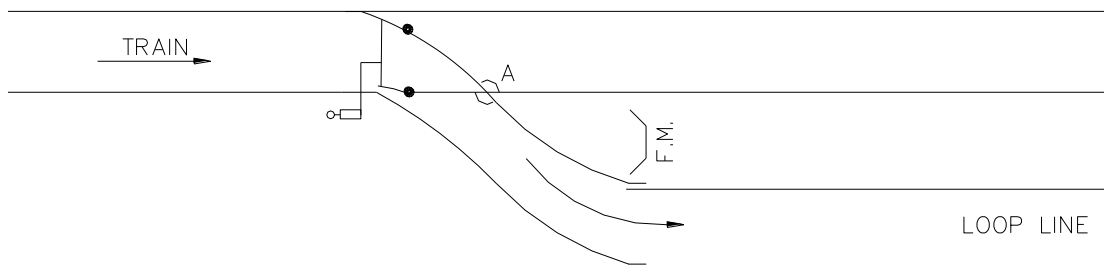

You may see that in both the above cases, when one switch rail is closed with its stock rail, the other switch is open. In either case, the opening shall be $4\frac{1}{2}$ ". Between the closed switch and its stock rail not more than $\frac{1}{8}$ " gap, is permitted.

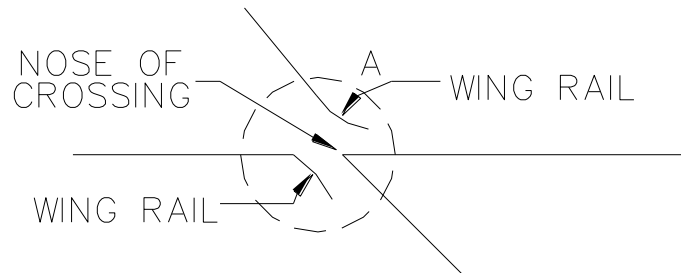

The centre to centre distance between the adjacent tracks (between main line to the adjacent loop line or between one loop line and other adjacent loop line) shall not be less than 14'0". Where cross-over points are provided between adjacent tracks, this distance gets reduced. At the place where it is less than 14', one track may foul the other track. At this point a 'fouling Bar' (a cement slab of about 5' length with inscription "FOULING MARK") is provided.

When a train drawn on a track, it should stand clear of the FOULING MARK as otherwise, the train may foul the movement of train on the adjacent track, thereby causing a side-collision.

Clearance of track:

Since a train can not be received on the portion of track where another train is standing on same portion of the track, the signal before it is cleared for the movement of a train has to ensure the track clearance. There are equipments used in Railway signaling to achieve the above safety condition.

Types of Signals

Signal:

Signal is a medium to convey a particular pre-determined meaning in non-verbal form.

Multiple Aspect Color Light Signal (MACLS):

Multiple means more than 2 indications .They may have 3 or 4 different aspects or indications to be given to the driver. These signals have longer range of visibility and Improved reliability.

Classification of CLS:

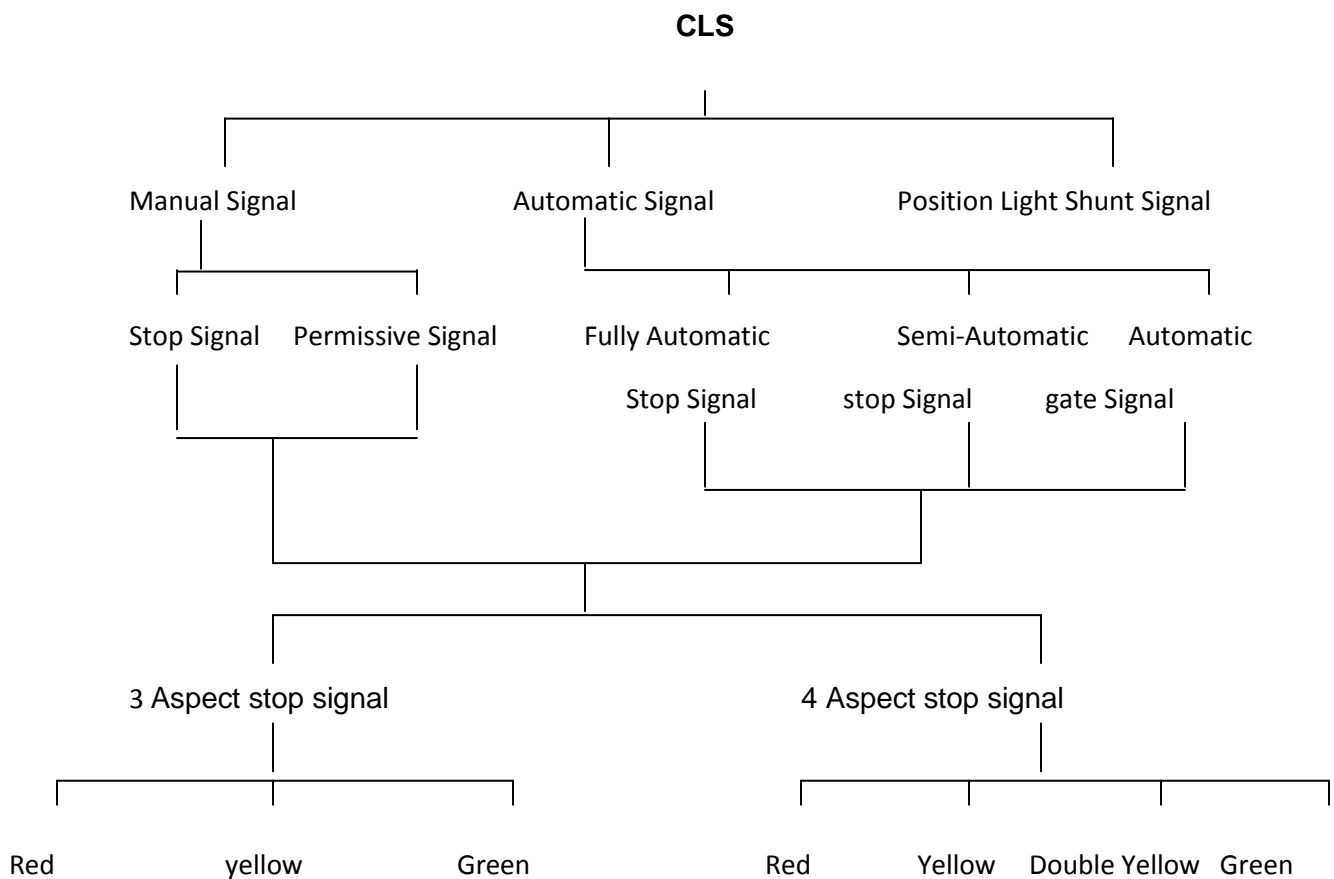

Manual Stop Signal :

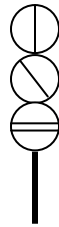

Each aspect of the signal is represented by a circle. A horizontal line inside the circle indicates Red aspect, an inclined line the yellow aspect and vertical line the Green aspect. The normal aspect of the signal is shown by double line.

Aspect	Meaning	Indication to the driver
Red	Stop	Stop dead
Yellow	Caution	Proceed & be prepared to stop at the next stop signal
Green	Proceed	Proceed

Permissive Signal (Distant Signal) :

Shall be located at an adequate distance in rear of the stop signal, the aspect of which it pre- warns.

The normal aspect of permissive signal is 'Single Yellow'

where 2 distant signals are provided to pre- warn the stop signal, the outer most signal, to be located at an adequate distance from the first stop signal, shall be called the distant signal and the other called the inner distant signal, with the distant capable of displaying 'attention' or 'proceed' aspect only .

To distinguish between stop signal and permissive signal ' P 'marker board (letter in black on white board) is fixed to the permissive signal.

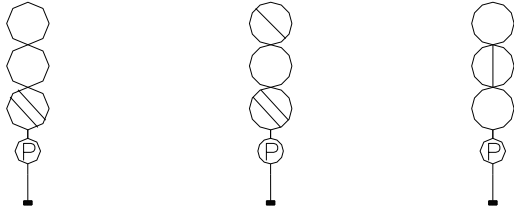

Aspect	Meaning	Indication to the driver
Yellow	Caution	Proceed and be prepared to stop at next stop signal
Double yellow	Attention	Proceed and be prepared to pass next signal at such a restricted speed as may be prescribed
Green	Proceed	Proceed

Automatic Stop Signal :

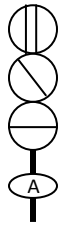

The normal aspect of an automatic signal is green and is indicated by the double vertical line, unlike the manual signal where the normal aspect is red and indicated by double horizontal lines.

An automatic signal has an 'A' marker plate fixed to the signal post to distinguish it as an automatic signal. Letter 'A' in black on white circular disc.

Semi-automatic Stop Signal :

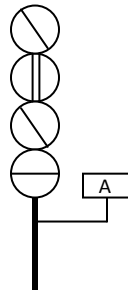

An illuminated 'A' marker distinguishes a semi – automatic signal from a fully automatic signal. Letter 'A' against black back ground is illuminated when working as an automatic stop signal and letter 'A' extinguished when working as a manual stop signal .

Gate Signal :

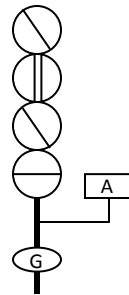

The Gate stop signal shall be provided with 'G' marker. Letter 'G' in black on a yellow circular disc.

A semi-automatic stop signal interlocked with a level-crossing gate shall be provided with 'G' marker disc and an illuminated 'A' marker. The 'A' marker shall be lit only when the gates are closed and locked against road traffic.

Routing Indicator :

Where two or more lines diverge, information is to be given to driver that he is being received on diverge line. Hence route indicators are provided.

Route indicators are fixed on the first stop signal and starters.

If the route indicator on a signal is not in working order, the relevant signal shall also to be treated as defective signal.

Route indicator is denoted as (UG).

Route indicator are of three types.

Junction type route indicator :

Used where the speed is above 15KMPH

It is having a provision of indicating six diversions and a straight line.

When taken off it shows a row of five white lines.

Multi lamp route indicator :

Used where the speed is less than 15 KMPH.

It can exhibit nine numerals and alphabets.

Stencil type route indicator :

Normally fixed on starter signal.

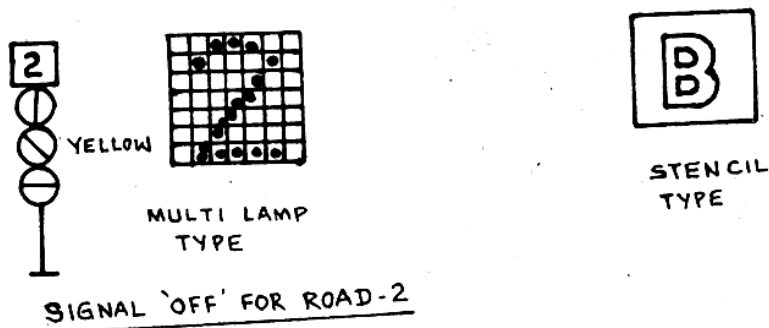
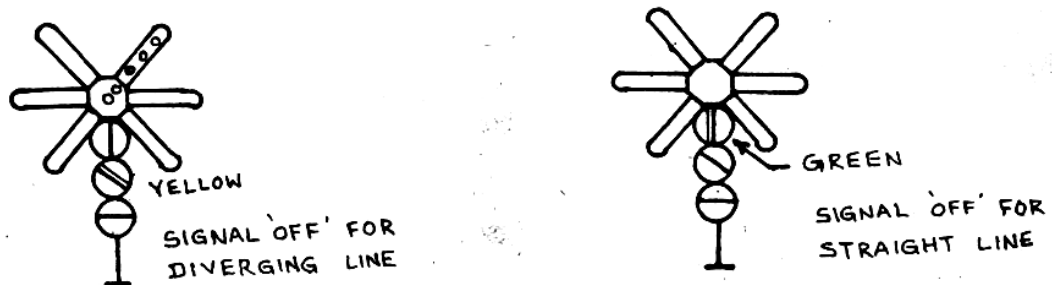

FIG. 1.7.15 (a) ROUTE INDICATORS MULTILAMP OR STENCIL TYPE



Subsidiary Signals

Signals are used for reception of trains in to a station and despatch of trains out of station. Signals used for movement of trains with in the station section at restricted speed and for special purpose are called Subsidiary signals.

In MACL signalling Shunt signals and Calling-on signals come under subsidiary signals

Shunt signal :

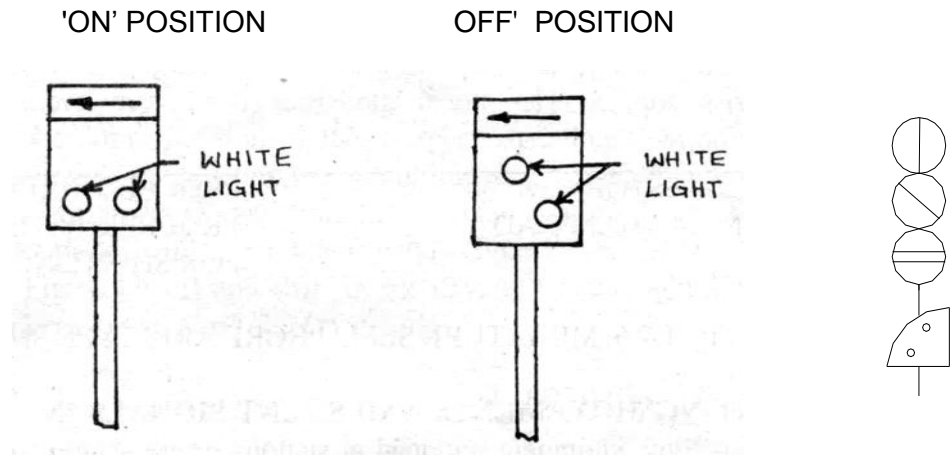

Aspect	Stop	proceed slow-
Indication	Stop dead	proceed with caution for shunting

Fig. Position light shunt signal

It is of position light type, The lights shall be white in colour. Shunt signals control shunting movements.

A shunt signal may be placed on a post by itself or below a stop signal other than the first stop signal of a station.

When a shunt signal is taken 'OFF', it authorizes the driver to draw ahead with caution for shunting purposes although stop signal, if any, above it is at 'ON'.

When a shunt signal is placed below a stop signal, it shall show no light in the 'ON' position.

Calling-on signal :



A Calling-on signal has no independent location and displays no aspect in 'ON' position. A calling-on signal where provided, shall be fixed below a stop signal governing the approach of a train with 'C' marker board fixed to the signal post. A calling-on signal when taken 'OFF' it displays a miniature yellow light.

Under approved special instructions, a calling-on signal may be provided below any other stop signal except the last stop signal.

When placed below a stop signal, it shall show no light in the 'ON' position. A calling-on signal under main signal above it cannot display "OFF" aspect at same time.

Markers & boards:

Warning Board: Provided to warn the driver that he is approaching a stop signal. To draw attention of the driver in the night, self-reflecting sheets are fixed. It is located not less than 1.5 Kms. in rear of FSS. Where double distant is provided, warning board is dispensed with.

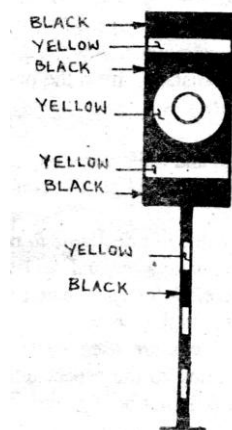

Shunting Limit Board: Provided on single line sections where shunting in the face of approaching train is permitted. Placed at a distance not less than 180 Mts. from the opposing First stop signal.

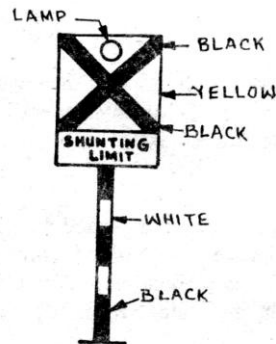

(a) SHUNTING LIMIT BOARD

Block Section Limit Board: Provided on double section where there are no facing points or the outer most points at the approaching end are trailing. It shall be placed at a distance not less than 180 Mts. from the first stop signal.

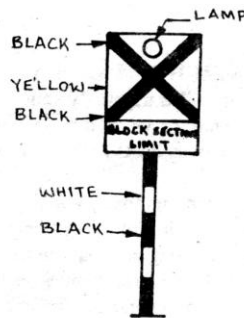

(b) BLOCK SECTION LIMIT BOARD

Outlying Siding: Where an intermediate siding taking 'OFF' in the facing direction in passenger running line outside station limits is provided with 'S' marker board to indicate that a siding is taking 'OFF' from main line.

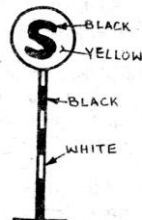

(c) S MARKER BOARD FOR OUTLYING SIDING

Concept of Overlap and Isolation

Every stop signal by its indication to the driver controls the movement of train upto the next stop signal as the next stop signal will control the movement beyond it. Hence the track between the stop signal and the next has to be clear and the points have to be correctly set and locked before a movement is permitted by it. However due to any unforeseen reasons like with sudden brake inadequacy the driver may not be able to stop at the next stop signal. So an extra safety margin of the track beyond the next stop signal is also to be kept free so that if the train overshoots the next signal, he will be able to bring the train to stop within that margin. This safety margin is called “overlap”.

Similarly we have to ensure that when a train moves on the track the other rail vehicles from the adjoining track should not roll down and infringe with the movement. To prevent this “isolation” between adjoining lines is required.

Overlaps

Overlaps are referred to as ADEQUATE distance. Overlaps are of two types:

- 1) Block Over Lap (BOL)
- 2) Signal Over Lap (SOL)

Block over lap : It is the extra length of track in advance of the FSS (First Stop Signal) of a station, which must be kept clear, before Line clear can be given to the station in rear.

BOL in MACLS sections shall not be less than 180 Mts.

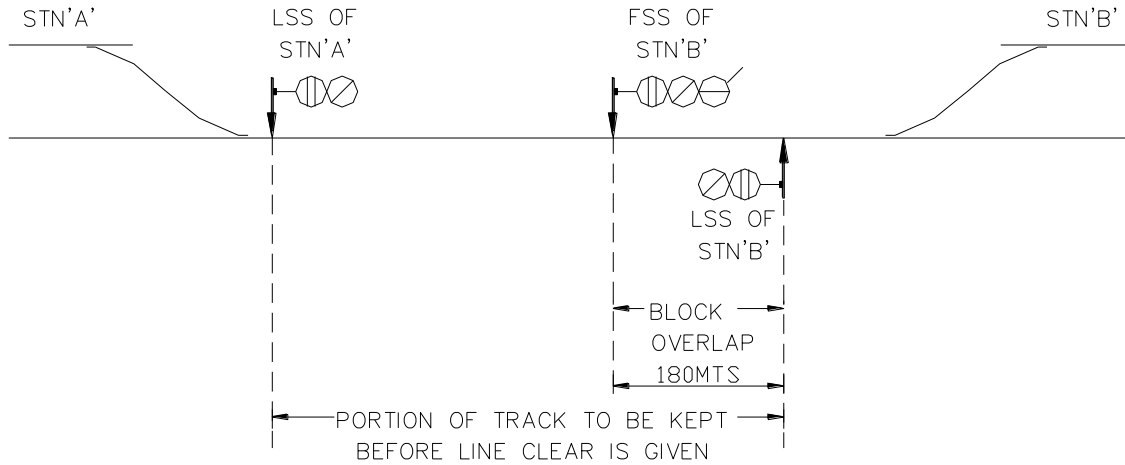

Signal over lap : The length of track in advance of a stop signal of station, which must be kept clear, before the signal next in rear could be taken 'OFF'.

SOL in MACLS sections shall not be less than 120 Mts.

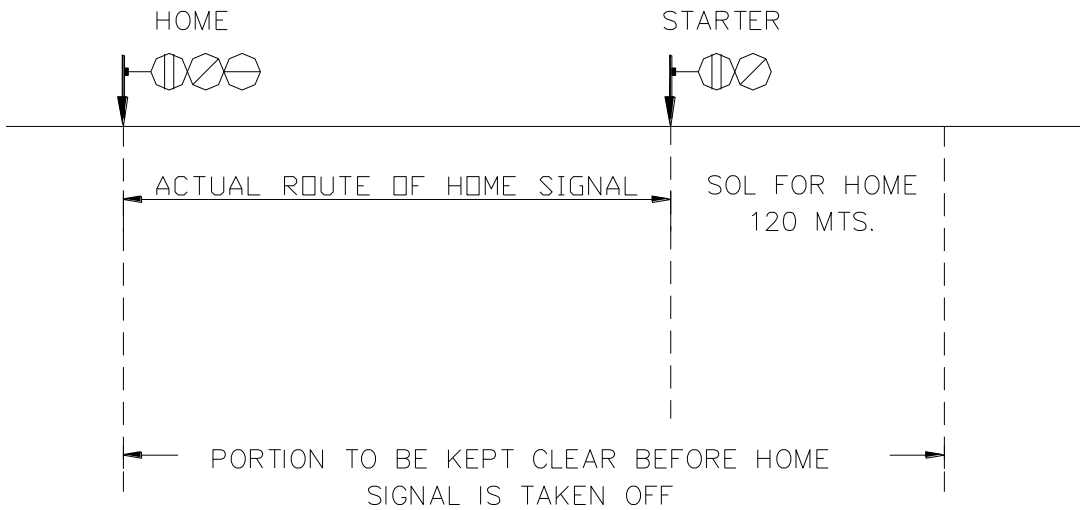

Incase of Automatic signals the adequate distance is 120 Mts. minimum.

Isolation

The term isolation denotes the condition in which line for a particular movement of a train is separated from all adjoining lines connected to it in such a manner that it cannot be fouled or interfered with by any movement taking place on the adjoining lines .

Rules regarding isolation:

- A line, on which train movements at speeds higher than 50 KMPH are permitted, should be isolated from all connected lines.
- Passenger lines should be isolated from all connected goods lines and sidings, whatever the speed may be.
- Isolation of goods reception lines from sidings is considered desirable.
- To maintain safety in through running, points and trap sidings should be not be inserted in the main or through line except with the permission of CRS.
- Where other means cannot be adopted to permit simultaneous reception on a single line.
- To trap vehicles running away from a station.
- To avoid trains entering from block section due to heavy falling gradient

Methods of Isolation :

- 1) Connecting to another line or a siding.

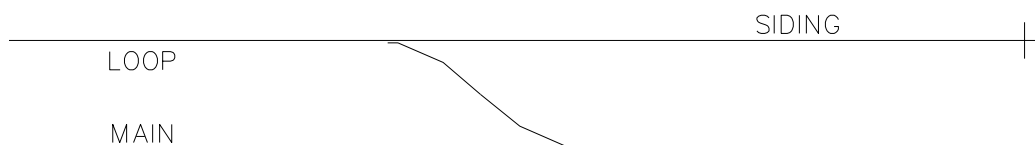

- 2) Provision of short dead end siding
(Vehicles not to be stabled on siding)

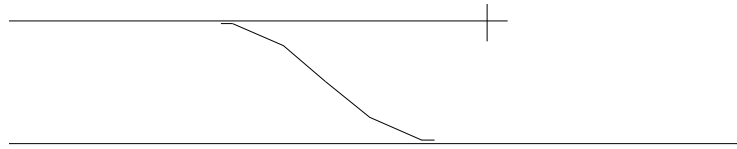

- 3) Provision of traps derailing switches

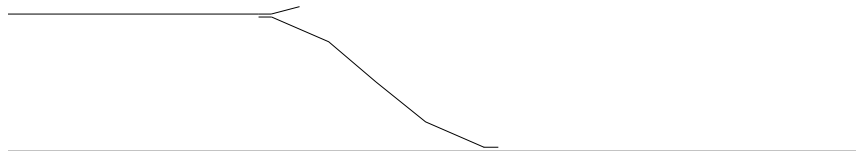

- 4) Provision of double derailing switch with lead rails without crossing.
5) Long dead end siding with trap (vehicles can be stabled on this siding).

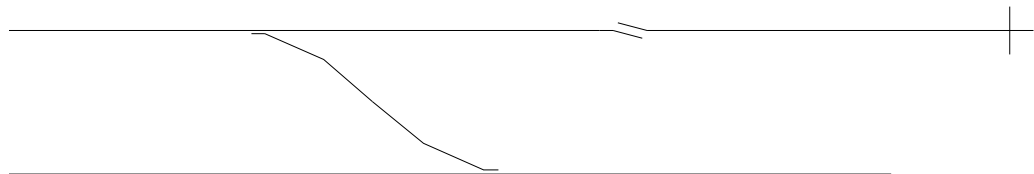

- 6) Provision of sand humps.

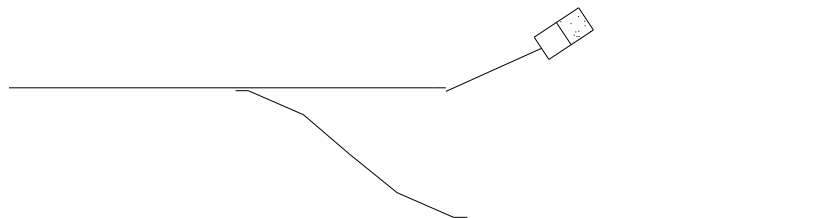

Slip Siding & Catch Siding:

On Indian Railways for all gauges the maximum gradient permitted is 1:400, where as 1:1200 is usually allowed within the station yard. No station yard should be steeper than 1:260, except due to geographic conditions. Where such gradient cannot be avoided within the station yard, condition of CRS is to be obtained for providing 'SLIP SIDING'. Slip siding will prevent vehicles entering block section.

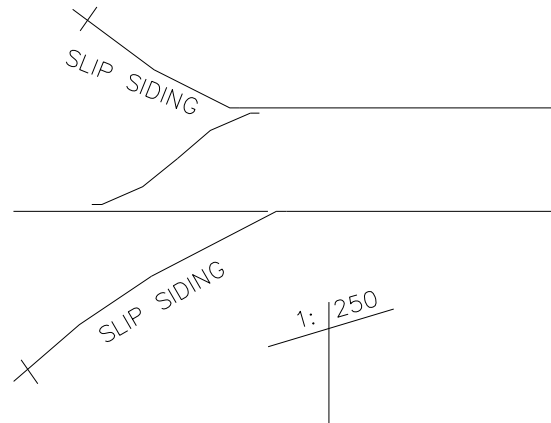

Where gradients are steeper than 1:80 falling towards the station, to prevent vehicles entering station section from block section. This arrangement is known as 'CATCH SIDING'. Catch siding will prevent vehicles entering into block section.

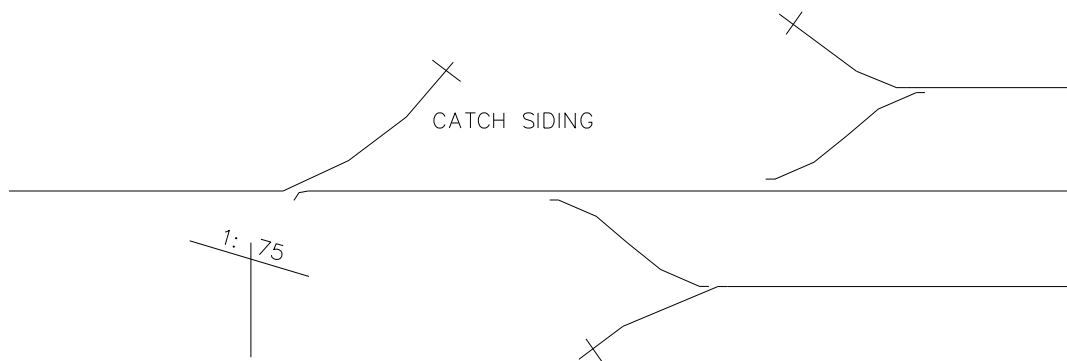

Slip sidings and 'Catch sidings' points must be interlocked with block instruments and these sidings should not be used for shunting or stabling purposes.

Location of Signals

Home Signal : On single line, shall be placed at not less than 300 Mts. in rear of the first facing point. On double line may be located at a distance of not less than 180 Mts. in rear of the facing points or BSLB.

Distant Signal : On single line or double line shall be placed at an adequate distance of normal braking distance which shall not be less than 1 KM from the stop signal. If the second distant is used, the inner distant is to be 1 KM in rear of home signal (first stop signal) and outer distant is to be 1 KM in rear of inner distant.

Routing Signal : Shall be placed just in rear of the facing points to it protects.

Starter Signal : Placed in rear of the facing point or fouling mark of the converging lines such that they should protect the adjacent running line.

Advanced Starter : Shall be placed outside all the connections on the line to which it applies, and shall not be less than 120 Mts. from the outer most point on single line. On double line this distance is from the starter signal and in special case upto a distance of full train length beyond outer most point where frequent shunting is involved the main line.







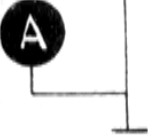

APPEARANCE	PROVIDED ON	DESCRIPTION
	Automatic stop Signal	Letter 'A' in black on white circular disc.
	Semi-automatic stop signal	White illuminated letter 'A' against black background when working as an automatic stop signal, and letter 'A' extinguished when working as a manual stop signal
	Colour light Distant or Warner signal on a post by itself.	Letter 'P' in black on white circular disc.
	Intermediate block stop signal	Letter 'B' in black on white circular disc.
	Calling on Signal	Letter 'C' in black on white circular disc.
	Repeating signal in Semaphore signalling territory	Letter 'R' in black on white circular disc.
	Repeating signal in colour light Signalling territory.	White illuminated letter 'R' against black background.
	Gate stop signal	Letter 'G' in black on yellow circular disc.
	Gate stop signal in automatic block territory.	Letter 'G' in black on yellow circular disc. And white illuminated letter 'A' against black background.
	Gate stop signal in semi-automatic territory when interlocked with points also.	White illuminated letter 'A' and 'AG' against black background.

FIG. MARKERS PROVIDED ON SIGNAL POSTS

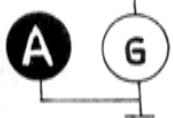
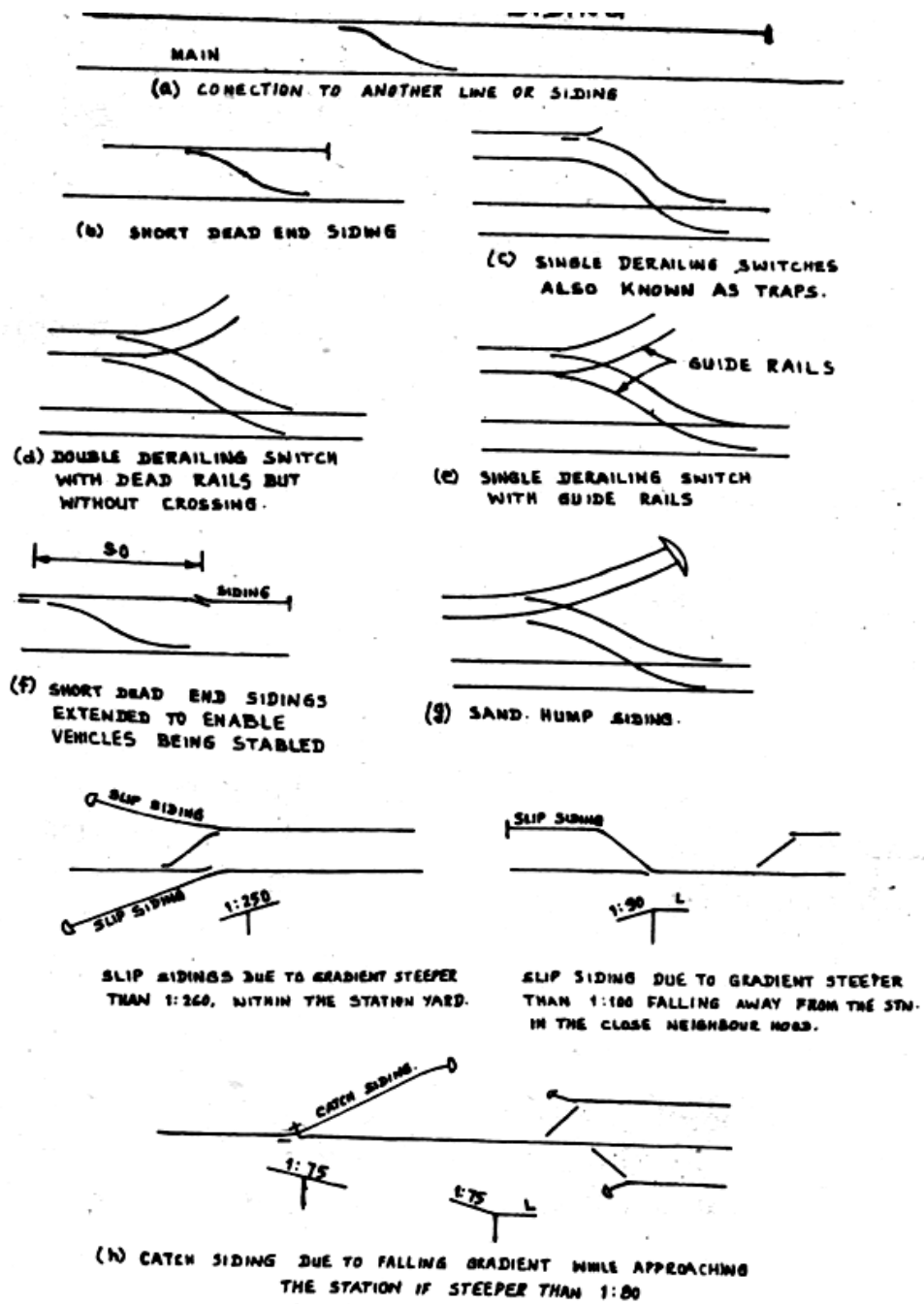

Fig. METHODS OF ISOLATION

Signalling Plan

4

Chapter

For any station whether a wayside or a junction, the Engineering department prepares a plan depicting all the lines, points, Level Crossings if any, Foot-over Bridge (FOB), Sub-way if any coming within the station section, Bridges if any, gradient etc. This plan is called as the "P-way Plan". This plan is studied by the Signal Engineers and based on this a Signalling Plan is prepared indicating the following:

- All gradients with in the station limit on either side upto 2.5 Kms.
- Kilometer and class of level crossing gate within the station limits, whether interlocked or not.
- Up & Dn direction, Name of important junction and immediate station on either side.
- Location of signals, with reference to point and level crossing gate.
- Marking of signals, points and level crossing gates.
- Inter signal distances and distance between warning boards & signals
- Type of Block working with adjacent station and location of Block instrument.
- Type of turnouts.
- Description of siding.
- Restriction on dead end sidings.
- Crank handle details.
- Details of Axle counters / Track circuits.
- Signalling Over lap.
- Holding capacity of all running lines and sidings.
- Note regarding telephone communication provided between ASM and Level crossing with in and out of station section.
- Reference to approved engineering plan on which the signalling plan is based.
- CRS's dispensation for deviation from G&SR / SEM, if any.
- Aspect sequence chart for CLS.

- Name of the station, Standard of station.
- Class of station, Centre line with kilometers, North point.
- Names of the stations with distance on either end of the station.
- Panel position / SM's control, with spare knobs / slides.
- Detection table.

A typical signaling plan can be seen. All signals and points are given a number, as per certain standard conventions.

First the civil Engineers who lay the track structure on the ground prepare a plan called permanent way plan or Engineering scale plan. Based on this plan signaling plan is made by signal engineers for catering to the train operation requirements.

One of the unique features of Railways working is the level crossing gate where a road and the rail track cross each other at the same level. The level crossing gates are of following types.

1. Manned and interlocked with signals.
2. Manned and not interlocked with signals.
3. Unmanned Level crossing.

When the standards of Interlocking are discussed. Interlocking of level crossings with signal will also be covered. If the interlocked gate is within the station limits, the station signals will protect the movement of trains over the gate. If the interlocked gate is in the block section, independent signals will be provided on either side of the gate and will be controlled by the Railway. Staff manning the gate.

Drawing

Drawing

Signalling Equipments

5



Chapter

Meaning of alphabets used to denote Signalling Information

A	Approach, Automatic. Near end point.
B	Block positive energy, Far-end point.
C	CONTACT. Center, Check.
D	CLEAR, GREEN
E	EARTH, LAMP
F	FRONT, FUSE
G	SIGNAL, GATE
H	CAUTION YELLOW.
HH	ATTENTION, DOUBLE YELLOW
I	CURRENT,
J	TIME DELAYED ACTION
K	INDICATION
L	LOCKING
M	MOTOR, MARKER
N	NORMAL, NEGATIVE
P	PUSH, REPEATER, POWER.

Q	SECONDARY, COIL.
R	RELAY, RED, RIGHT, REVERSE.
S	STICK
T	TRACK, TIME, TERMINAL
U	ROUTE, UNIT.
W	POINT, SWITCH
X	BELL, BUZZER, CROSSING, INTERLOCKING
Y	SLOT, RELEASE
Z	USES FOR ANY SPL TERM.

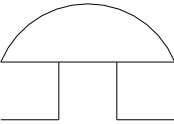
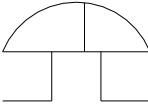
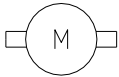
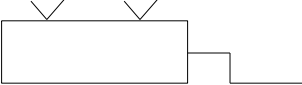
Symbols used in railway signalling.

DC Bell	
Block Bell	
Motor	
Motor Crank Handle	
Electrical Point Machine	

Fuse

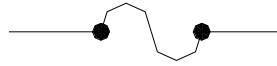

Cell

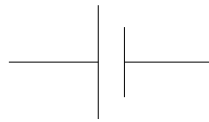

Battery

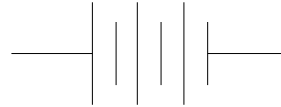

Normal Detection Contact

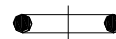

Reverse Detection Contact



Push Button Contact

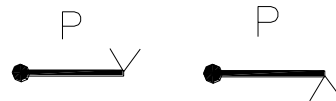

Earth

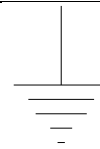

Cabin

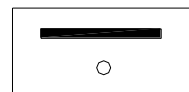

Relay



Relay with slow release feature



Slow to pickup feature relay



AC immunized Relay



Contact of Neutral armature

Independent Front contact



Independent Back contact



Dependent contact

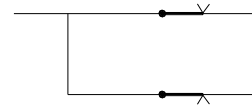

Track Circuit portion



Fedover Track Circuit

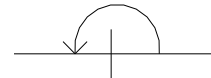

Terminal Block

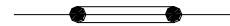

Half wave rectifier

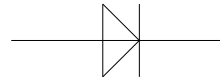

Full wave Bridge Rectifier

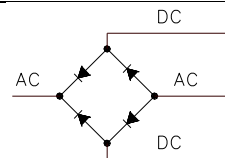

Trap Indicator

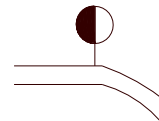

Un manned Level crossing

Interlocked Level crossing

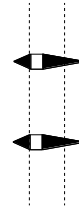

Worked from Panel

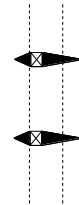

SMS Slide Control



EKT

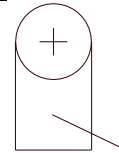

Axle Counter

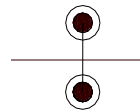

Block Instrument

Single Line Token instrument

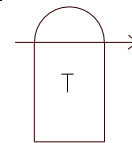

Single Line Token less instrument

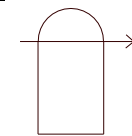

Double line instrument

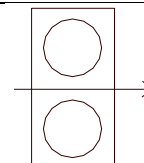

Cables

Cable is a unit, which contains more than one insulated conductor bunched in to a compact form by providing mechanical protection and electrical insulation.

PVC insulated, PVC sheathed and armoured signalling cables are used for carrying signalling circuits. Conductors are of copper and of approved size. Cables are classified as 'INDOOR' cables and 'OUTDOOR' cables.

Indoor cables:

Used for internal wiring of signalling circuits with copper conductor, PVC insulated without armour.

Indoor cables are normally in size 60 core, 40 core, 24 core, 20 core with conductor size 0.6 mm dia. or 60 core , 40 core , 24 core & 16 core of 1.0 mm conductor dia. size.

Outdoor cable:

These are classified as Main cable, Tail cable, Power cable and Quad cable as per circuit connection requirement.

Main and Tail cables are available in 4 core , 6 core , 8 core , 12 core , 20 core , 24 core and 30 core, with conductor size 1.5 sq. mm area.

1.5 sq mm (Copper conductor) 2 core size cable are used for track circuits (Feed end & Relay end) Numbering is generally started from outer most layer i.e., Starting from Blue and ends with Yellow.

Power cable:

Used as BUS BAR for power supply from relay room to location boxes.

Sizes are 10 sq mm Aluminum single strand 2 core cable. 25 sq mm Aluminum single strand / multi- strand 2 core.

Quad cable:

Used for Axle counter circuits, Block line circuits. There are of 6 or 4 quad cable (1 quad = 4 conductors arranged in 2 pairs)

Testing of signalling cables:

Periodicity of Main cable Once in year, Tail cable Once in six months, Life of signalling cable 30 years, 500 volts DC Megger to be used for testing of cable.

The insulation resistance should not be less than 5 Meg ohms / Km in dry weather. (For 500 Mts. 10 Meg ohms, 250 Mts. 20 Meg ohms)

Electrical Key Transmitter

Electrical key transmitter is used for the purpose of controlling a signal apparatus such as points, LC gates & signals etc by SM by retaining key of the controlled apparatus (which is normally locked) and issuing the same key for releasing the apparatus when required.

Under this system, the working of fixed equipment is locked by means of mechanical key which is electrically locked in the EKT.

For extracting the key from the EKT, a pair of EKTS is required to be connected in series, one at the function end and other at controlling end and requires physical co-operation from both end operators.

The EKT keys are so designed that they enter only the instrument meant for the specific key and can not enter any other instrument of its kind.

The EKTs keys are provided with provision of sealing

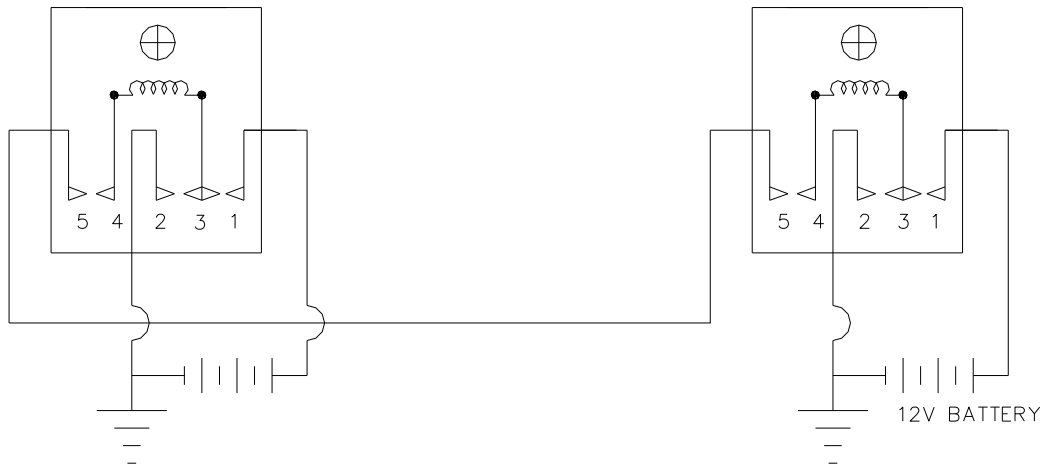

Keys out :	All contacts open
Key in & pressed to right side :	Contacts 5 & 4; 3 & 1 make
Key in :	Contacts 5 & 4; 3& 2 make

Electrical parameters:

Resistance of coil	- 12.5 ohms to 15 ohms
Rated voltage	- 12 V DC
Working current	150 mA to 200 Ma
Minimum Voltage	6V DC

Relays

Relay is an electromagnetic device which is used to convey message electrically from one circuit to another circuit through a set of contacts (back or front contacts) and works on the principle of electromagnetism.

Relays are classified as :

- According to source of power applied - DC Relays & AC Relays.
- According to mounting - Shelf type & plug in type.
- According to application. - Line relays & track relays.
- According to polarity on coils - Neutral relays, polarized relays and Biased relays

- According to contact material - Metal to carbon contact relays (non proved)
- Metal to Metal contact relays (proved)

- According to importance of circuit - Vital relay & non vital relays.
- According to immunization - AC immunized DC relays, Non AC immunized D.C .Relays

Shelf type Relays

- These relays are classified as neutral line and track relays. Both can be of AC Immunized or non AC immunized.
- Contact elements of front contact are carbon and metal for both back & movable contacts.
- Contact resistance for front contact is 0.2 ohms and back contacts are 0.5 ohms.
- Continuous contact current capacity is 3 Amps.

Comparisons of line relay & track relay

Function	line relay	Track relay
Working voltage	Normal 12 V DC	Minimum 125% & Maximum 250% of rated pickup voltage of relay.
Coil resistance	Two coil 500 ohm each	Two coils of each 4.5ohm Parallel connected 2.25ohm. series connected 9.0ohm.
Standard contact Arrangement	4F/B &6F/B (All are dependent)	2F/B ;2F-2F/B
Usage	other than tracks	connected to track only
Sensitivity	LOW	HIGH
Periodic Overhaul	15 years	10 years
Working	More voltage	less voltage
Minimum% release (Drop away /Pickup)	50% class "B" 60% class "A"	68%
Principle of working	Without any current De-energiser	Reduction in current causes relay to drop.

Plug- in type relays

Basic Constructional Features:

- Common plug board for all relays.
- Plug & socket kind of interconnection between plug board and relay.
- Retaining clip to hold the relay firmly.
- Connectors positively locked in the plugboard can be withdrawn by a special tool.
- Terminating wires on the connectors is both by crimping and soldering.
- Registration device with specified code combination to prevent interchanging of relays.
- Relay filled with gasket for moisture protection.
- Maximum numbers of contact are 16 independent metal to carbon type.
- Continuous current carrying of contact: 3 amps.
- Switching capacity : 2 Amps.

Type/style of plug-in Relays with metal to carbon type contacts.

Sl. No	style	description	contact arrangement	Application/where used
1	QN1	Neutral line relay	12F/4B,8F/8B, 8F/4B,6F/6B	for indoor and out door circuits in non-RE area
2	QNN1	Neutral line twin relay	6F/2B RH ; 6F/2B LH	Twin relays are used where minimum contacts are required.
3	QNA1	AC IMMUNISED DC Neutral relay.Immunity value 250v AC	12F/4B;8F/8B8F/4B	For external circuits in RE (Railway Electrified) area
4	QL1	Magnetically latched relay	8F/6B	For point Control
5	QJ1	Thermal time relay	2F/1B	For time delay circuits.
6	QBCA	Biased relay with AC immunity	2F(HD)/4B	Heavy duty point contactor relays to drive point machine
7	QT2	track relay	2F/2B	used in Non-RE area
8	QTA2	AC Immunized track relay	2F/2B	used in RE area
9	QSPAI	Slow to pick up AC immunized	8F/4B	used as reparative relay for QT2,QTA2 in RE area
10	QECXS1	Lamp proving	4F/4B	ON aspect lamp proving
11	QECXS2	Lamp proving	4F/2B	OFF aspect lamp proving.

Metal to metal contact plug-in type relays

These relays fall under the category of proved type relays. Since metal to metal contact can cause fusion or welding when current is interrupted due to circuit making or breaking, proving of back contact is necessary. Otherwise cutting the power to the relay can not be assumed to drop and break the front contacts (picked up contact due to exercitation of the relay)

Specification:

Coil resistance	-- 1260 to 1840 ohms
Rated voltage	-- 60V DC
Minimum number of contacts	-- 8 Nos.
Contacts combination	-- 4F/ 4B; 5F/3B; and 6F/2B.
Contact rating.	-- 5 Amps

Relays supplied can be of neutral relays, interlocked relays or lamp proving relays. Further these relays may be supplied as Mini group consists of two relays on a base plate pre-wired. Minor group with of 15 relays for route, signal functions. Major group with of 30 relays for point functions.

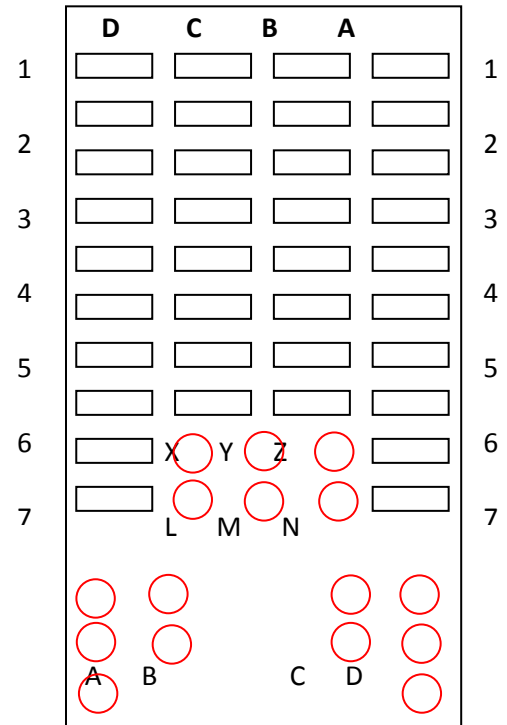
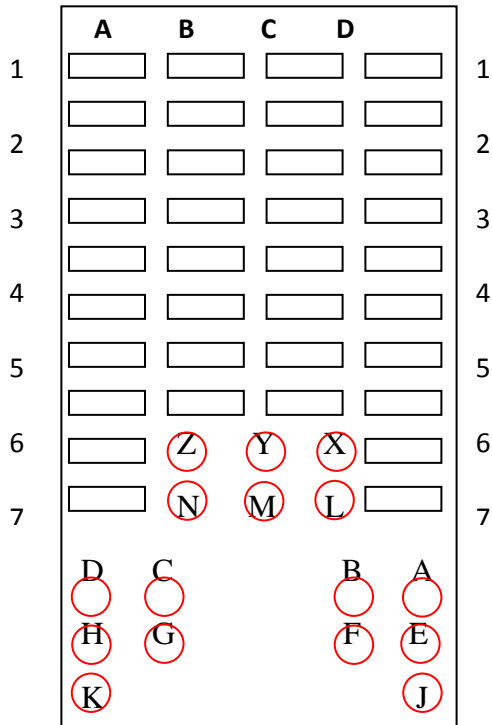

RELAY BASE VIEW

PLUG BOARD FRONT VIEW

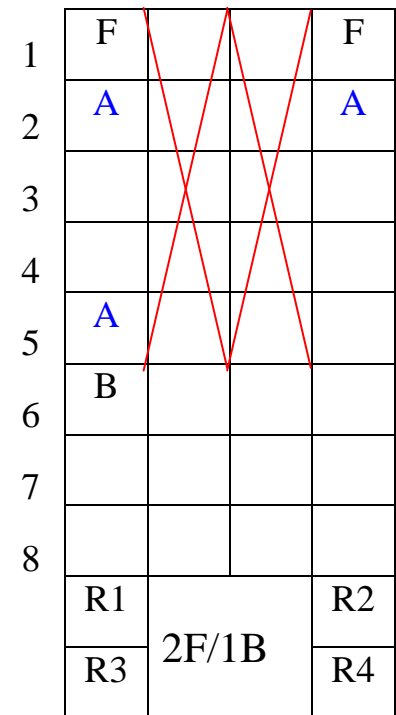
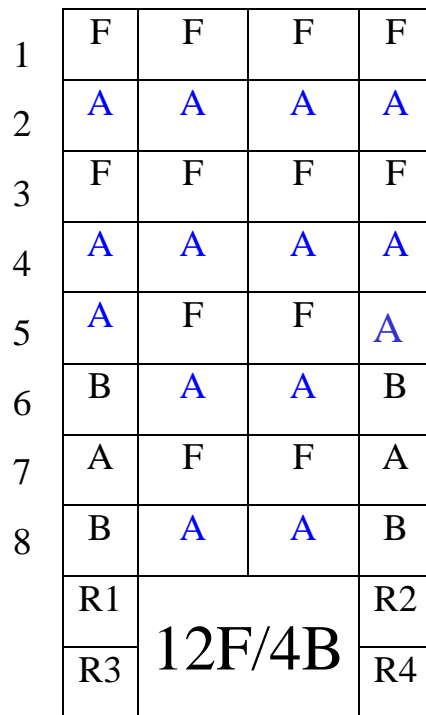
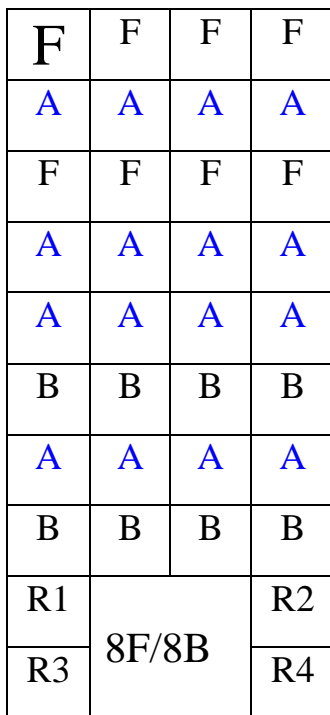

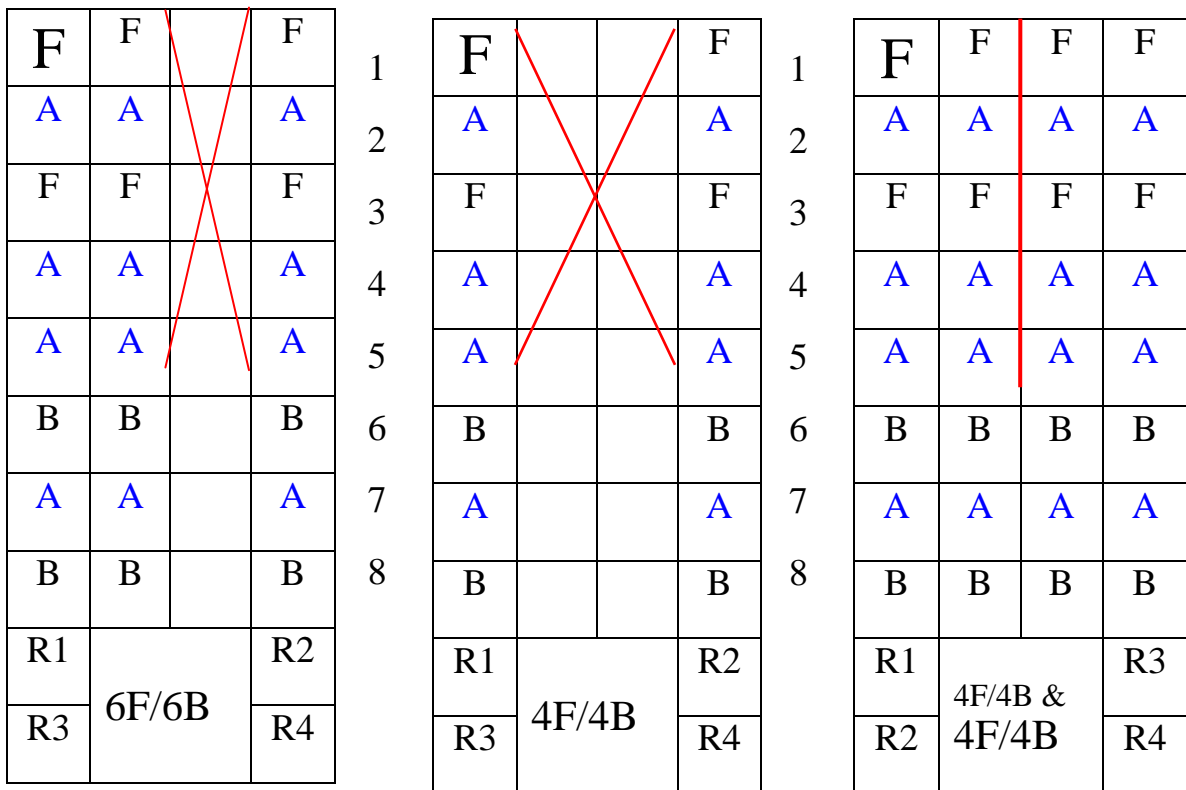

Electrical Detector

Electrical detector is an electromechanical device to check the position for correct setting and locking of points through making an electrical contact, which closes a circuit.

It has two sets of fixed contacts. In centre, bridging contact assembly on a roller cam shaft, which works in conjunction with the points and lock slides, makes the fixed contact as per the point setting.

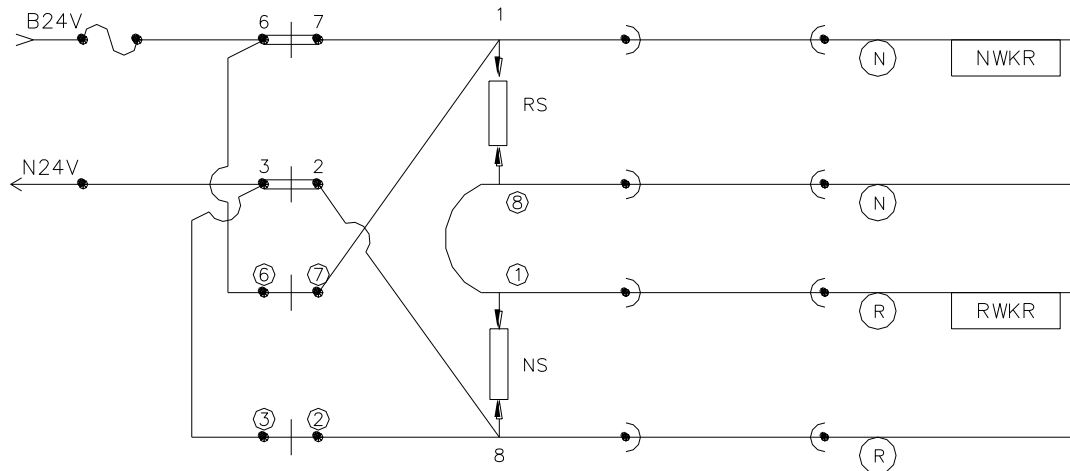

Point operating member (i.e., lever position) in the circuit ensures correspondence between lever position and point detection.. Normal shunt and reverse shunt contacts in the circuit ensure the conflicting relay is not energized from false or cross feed to ensure safety.

Shunt & Detection contact position during & after point operation.

Point position	normal detection	reverse detection	normal shunt	reverse shunt
Point normal & unlocked	open	open	made	open
Point normal & locked	made	open	made	open
Point reverse & unlocked	open	open	open	made
Points reverse & locked	open	made	open	made.

Track circuits

Track circuit is a vehicle detection device in which the running rails form part of an electrical circuit. The boundaries of track circuit are marked by insulation joints on the rail and rails are bonded at rail joints for better conductivity.

Uses of Track Circuits:

- For detecting the presence of vehicles or absence of vehicles within the limits of the track circuits.
- For locking the point when train is on the point.
- Trolley protection circuit for axle counter to ensure wheels of easily removable trolleys are not counted.

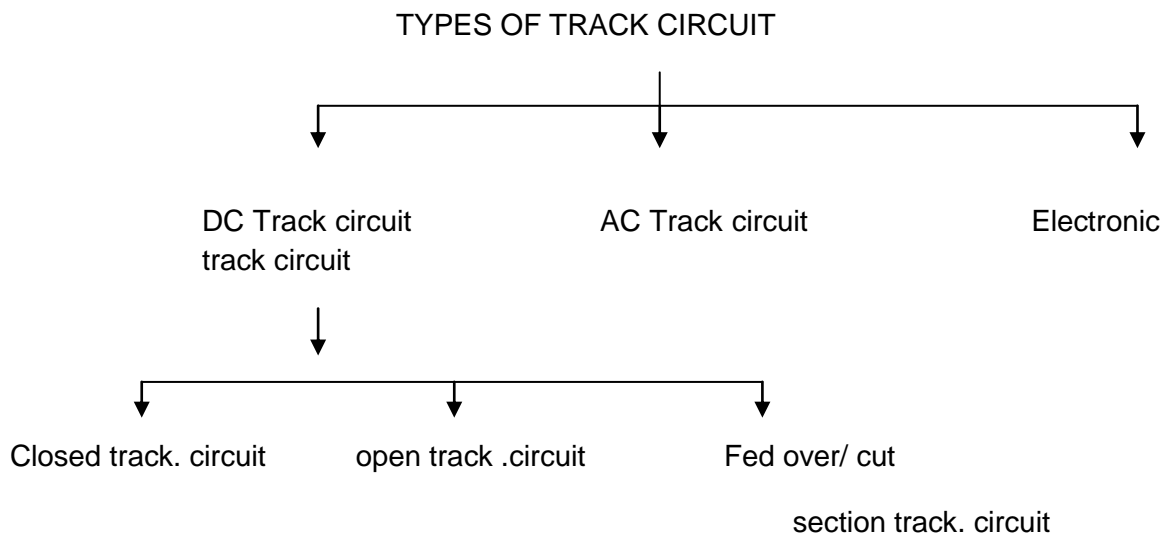

Closed TC : In this type current is always flowing through the relay. When train comes over the track, the supply to the relay is shunted and the relay de-energizes.

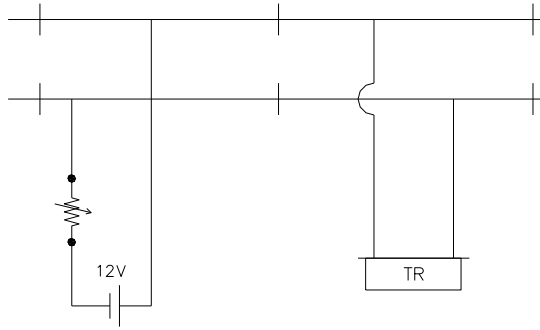

The smallest closed track circuit provided is of 26 meter length. The longest workable track circuit depends on the Ballast Resistance (i.e., Resistance across rails offered by the stone chips placed below the rail to support track), This ballast decides the leakage current. In other words ballast resistance appears across or in parallel with relay coil resistance.

Open Track Circuit:

Open track circuit is one in which the track relay is normally de-energized and picks up only when train comes on the track.

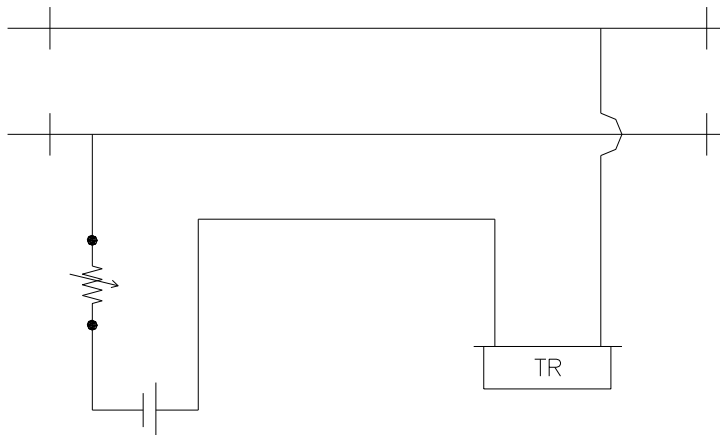

In this track circuit any disconnection with train on the track will drop the relay and failure on unsafe side will take place, as the relay will show track is clear under occupation. Hence this track circuit can be used for short length only i.e., 26 Mts. Now a days open track circuits are not used.

Fed over track circuit:

It is a sub division of track circuit. This is generally adopted when it is not possible to work a long track due to inability to maintain prescribed parameters like ballast resistance for fail safe working of track circuit.

Instead of dividing it in to independent track circuits, the first track circuit is fed by the usual battery and relay arrangement. The feed to the second track is taken through the front contact of the track relay which controls the first track and so on. The last track relay can serve to indicate occupancy or clearance of the portions of all track circuits.

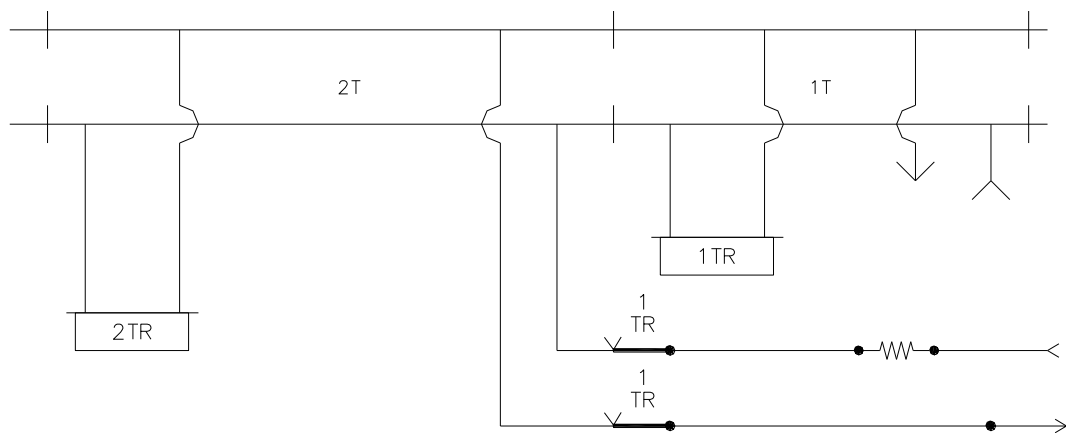

Triple pole lamps

Normally in the past signal lamps having 2 filaments as per following arrangement were used. The 2 filaments are Main (12 V 25 Watts) and Auxiliary (rated for higher than 12 V and wattage much less than 25W). Both filaments are in parallel connection by having the ends of the filaments brought on same 2 terminals. That is why these lamps are known as 2-pole 2-filament lamps. Due to the arrangement both filaments will glow together all the time. The hotspot that can develop at the place where they are close to each other is a source for fusing .If due to a higher voltage main filament may fuse, but auxiliary may not fuse due to its higher voltage rating, But output of auxiliary is less and lamp will be dim.

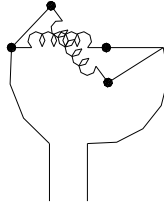

To overcome the above, CLS Triple lamps are nowadays used. There are two filaments of equal voltage and wattage. One filament (main) is lit normally and the second filament (auxiliary) is switched ON when main filament fuses.

Since both the filaments have same ratings and lumen output, the visibility of the CLS is not affected the two filament are provided in parallel configuration to avoid possibilities of hot-spot formation. One terminal of both filaments is common. While the other terminal is independent and hence 3 poles are used.

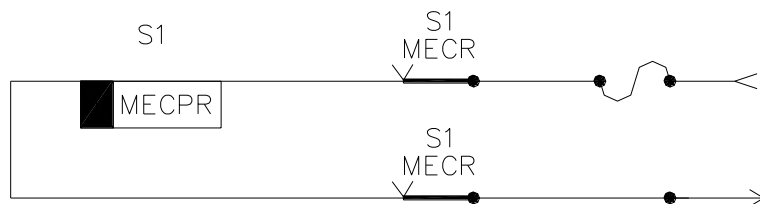
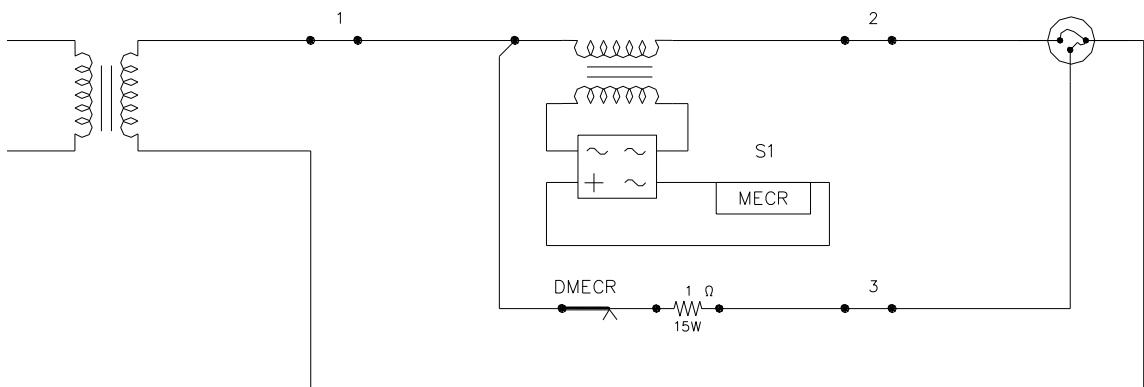

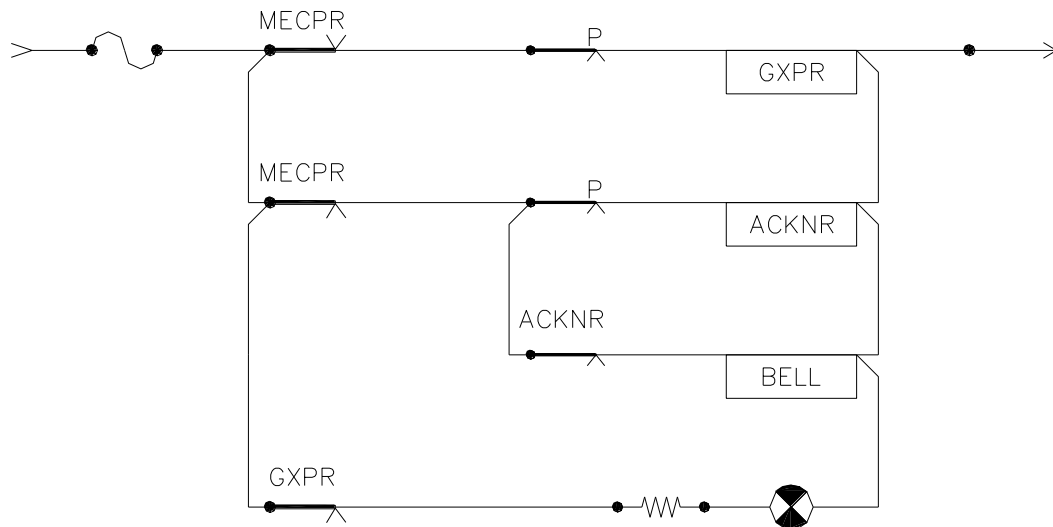

Led Signals

The salient features of LED Signals:

- No phantom effect.
- Pre-focused no need for periodical focusing.
- Wide voltage variation(90V -130Vv)
- Ac immunity value up to 300V. AC.
- Same kind of ECR s for ON & OFF Position.
- Minimum visibility in clear daylight weather is 600 Mts.
- Burning hours 1 lakh hours.

Led unit:

- It comprises clusters of LED in series and parallel combination.
- Main and calling on signal have two arrays.
- LED in each array ha electrically independent path.
- With failure of even single LED whole unit does not become blank and maintains uniform visibility.
- A few LEDs in the cluster are so arranged to ensure near visibility.
- Optical sensors are provided for each aspect.

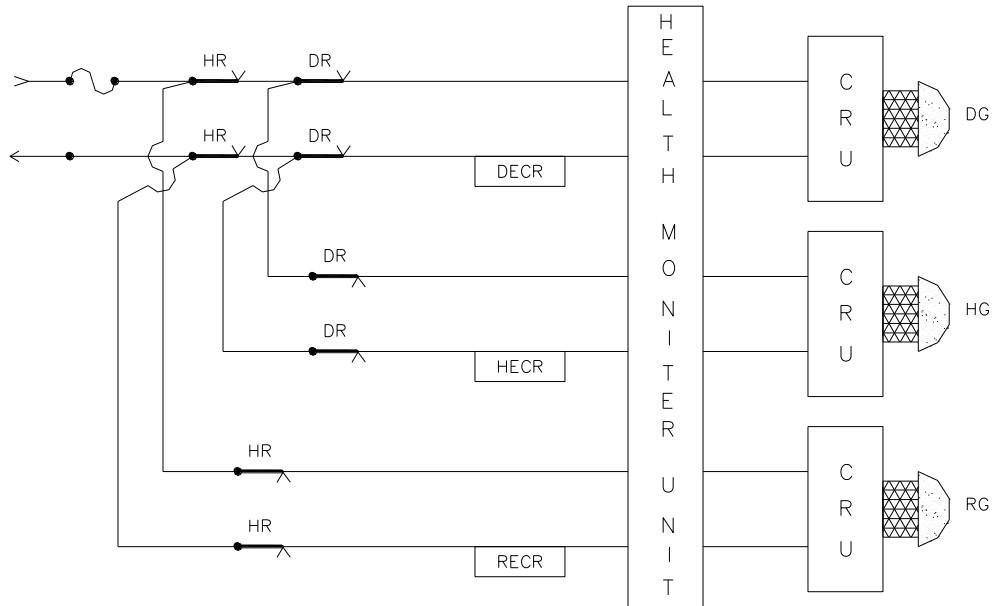

Current regulator

- Feeds constant current to LED signal unit.
- It detects the failure of 20 % to 25 % of LEDs.
- It limits or boosts the current, depending upon active LEDs and causes alarms.
- If optical sensor detects that the signal ahead has gone blank. or is dim ,it reduces the current to 300 mili amp and causes dropping of ECR and generates alarm.
- It has options for selecting blanking, non blanking and types of ECRs.
- Blanking facility is provided for “OFF“ aspects and non blanking is for ON aspect of main signal.

Health monitoring unit

It is provided for main signals at relay room.

- It monitors the performance of the LED Signal.
- It gives audible and visual alarms .When ,
 - Input current to regulator falls down below 50%
 - Illumination of LED unit ,falls below 50%
 - Current regulator is faulty.

Electrical Point Machine

An electrical point machine is an electrically driven motor used for operation of points in railway yards. The rotary motion of the motor is transmitted through the reduction gears and transmission assembly and converted through linear movement of a toothed rack through a pinion. The gear rack drives switch rails to unlock, change the position from N to R or R to N and lock the switch at the end of the stroke.

Sequence of point machine operation.

- Opening of the detection contacts.
- Unlock the points.
- Move the points to the desired position
- Lock the points.
- Close the detection contacts.

Depending up on the operating voltages

- Low voltage .DC supplies – 24 volt DC.
- High voltage DC supplies -110V DC.
- High voltage AC – 380 AC.

The point machines have split series field windings.

Electrical parameters of point machine

Rated voltage	110V DC.
Working current	4-6 Amps.
Obstruction (slipping current)	6-7 Amps.
Operating Time	3 sec.
Type of machine	Combined type. (Operation, locking and detection)
Field winding	Split field
Field connection	Series
Movement of locking	Rotary type
Friction clutch	Self adjustable

Main parts of point machine:

- DC series split field motor within built in reduction gear unit
- Transmission assembly
- Throw rod, lock slides and detection slides
- Detection and control contact switch assembly
- Hand crank.
- Spring loaded friction clutch.

Need for remote control of point machine:

1. To avoid voltage drop in cable cross section.
2. Contact of lever /knob/push button do not have the heavy duty current carrying capacity.
3. Track locking is to be provided to prevent point operation under wheels.
4. Point machine should be protected from over load.
5. Facility for sequential operation should be provided.

Two types of rely control units are standardized.

1. Siemens point contactor unit.
2. Point contactor unit with QBCA relays.

Note: In chapter 9.3 The point control circuits are explained.

Axle Counter

Comparison with track circuit.

- ❑ To detect the presence of vehicle within a prescribed distance is the role of track circuit.
- ❑ Dropping of track relay is due to shorting of rails by the axles of a vehicle train.

Disadvantages of track circuits:

- ❑ Either wooden or P.S.C. sleepers needed.
- ❑ Influence of B.R. and T.S.R. values (with weather).
- ❑ Controlled section length is limited.
- ❑ Insulation joints are compulsory or special type of track circuit is needed for joint less working.
- ❑ More maintenance due to varying track parameters..

Features of Axle counter:

- ❑ It works on magnetic flux variation on a ground device for counting the axles and electronic circuits to evaluate in-count and out-count. To detect the presence of wheel.

Advantages of using axle counter:

- ❑ It does not require wooden or PSC sleepers.
- ❑ It can cover very long sections up to 15 kms.
- ❑ It does not get affected either by flooding or poor maintenance of track.
- ❑ It does not require insulation joints and so the track can be long welded.

Application of axle counter:

- ❑ Monitoring of berthing tracks.
- ❑ Monitoring point zone tracks.
- ❑ For automatic signalling system.
- ❑ For Intermediate block signalling.
- ❑ Level crossing warning system.
- ❑ Proving block section clearance.
- ❑ At steel bridges in lieu of track circuits.

Various types of axle counter:

1. Analog axle counter (amplitude modulation),
2. Digital axle counter (phase modulation).

Analog axle counter:

1. Single entry-exit system (max. 2-D),
2. Multi entry-exit system (max. 4-D) (D = detection point)

Each detection point consists of a pair of TX/RX units.

1-D SYSTEM: common detection point for berthing tracks on terminal yards.

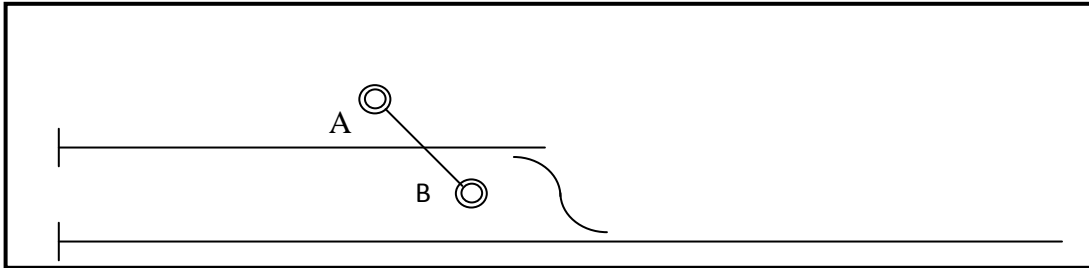

2D SYSTEM: berthing tracks, block sections, etc.

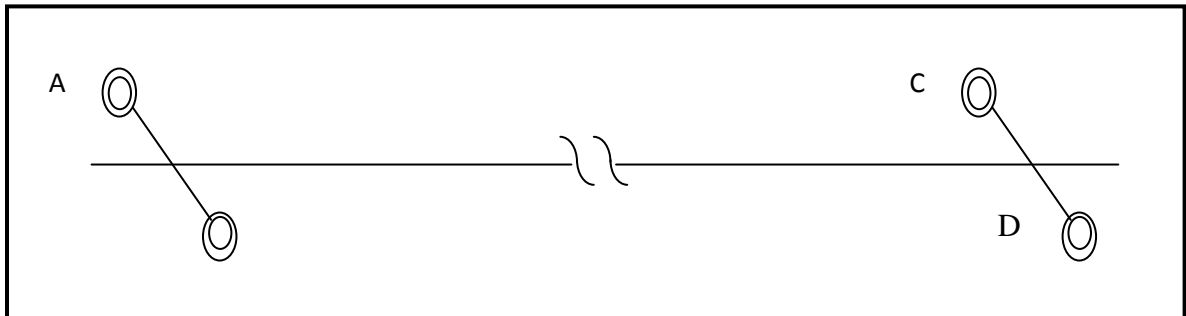

3-D SYSTEM: points, crossings, sidings, etc.

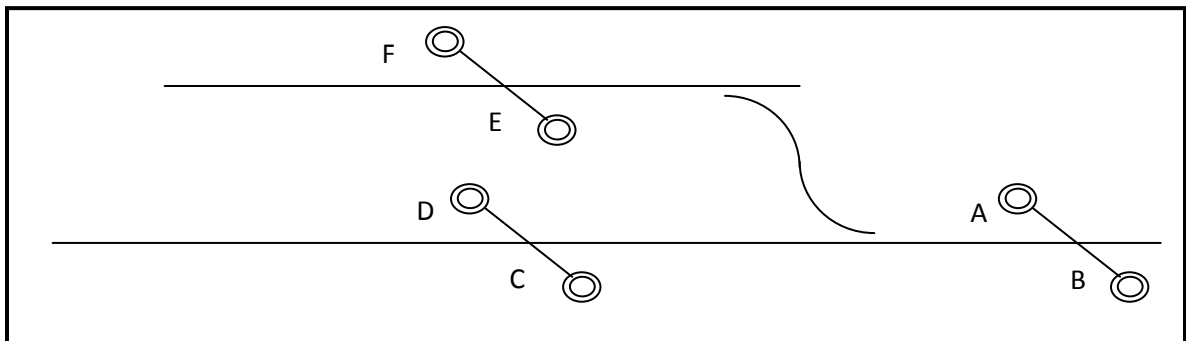

4-D SYSTEM: points, sidings, crossings and branch lines, etc.

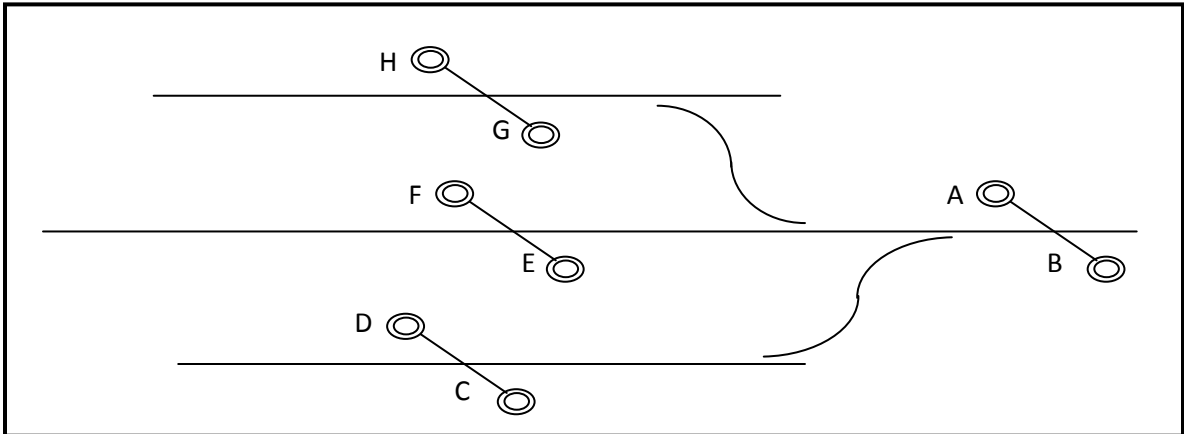

Operating Principle of Axle Counter

The tack equipment consists of 4 sets transducers (transmitter and receiver) fitted to the track at each detection point, The two sets at each end (detection point) fixed on same rail are staggered to discriminate the direction of traffic.

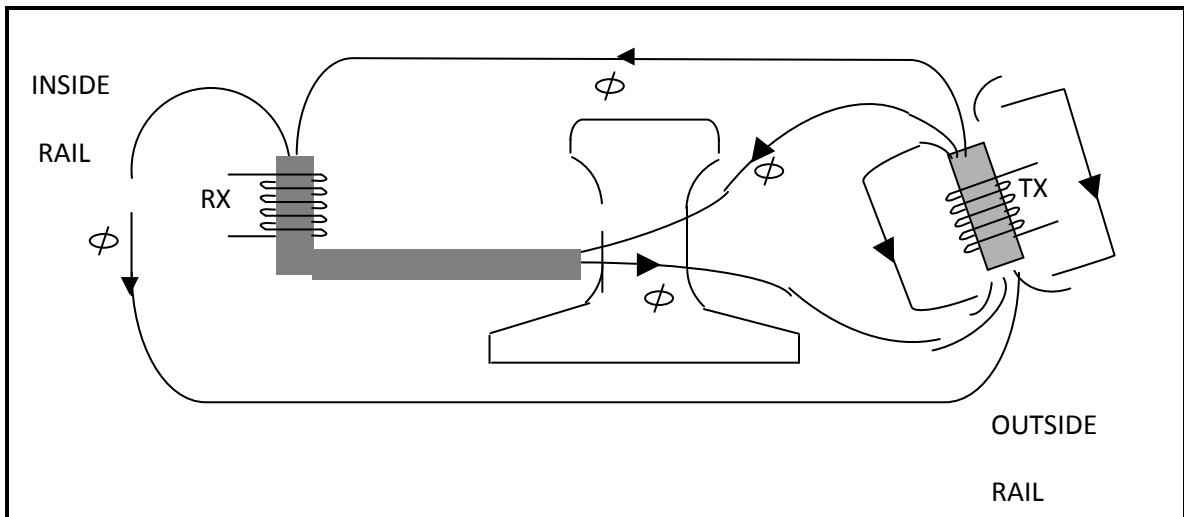

When power is given to Tx coil the magnetic flux is produced and it links with the Rx coil. The Tx and Rx coils are placed face to face. It produces a voltage in the Rx coil. When the wheel of train passes in between Tx and Rx coil, the magnetic flux linking them is cut and the voltage in Rx coil drops. This change in the level Rx coil is sensed as an amplitude or phase change. Depending upon the particular design, the out put of all the Rx coils (2 from one end of Axle counter section and 2 from the other end of Axle counter section) are taken to the evaluator located in the station, through Quad cable.

Then the 'IN' count and 'OUT' count are derived from the filed equipment and evaluated for comparison. If the in count and out count are equal the evaluator shows 'SECTION CLEAR'. If there is any discrepancy in the two counts, (it means some wagons / compartments are left in the section) and therefore the evaluator shows 'SECTION OCCUPIED'.

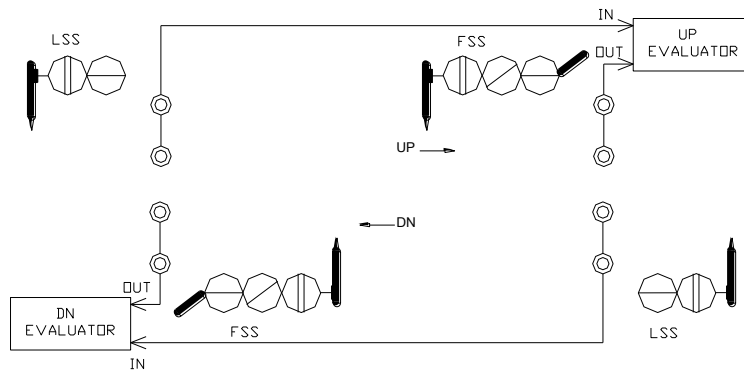

At the same detection point, if some axles enter into the section and then return, the system will show 'SECTION CLEAR', if the in and out count are equal.

Trolley-suppression Track circuit :

If a non- insulated push- trolley enters the track detections unit, the two axles will be stored as 2 in counts. The evaluator will show section occupied. The push-trolley can be physically lifted off the track and kept aside. Even though the section is clear the system will show section occupied. To avoid this, a short two rail length closed track circuit is provided at each diction point and the transducer equipment of the axle counter is fitted within the track circuit.



Only insulated push-trolleys are to be used, When the insulated push-trolley passes over the track relay will not drop. In which case, the evaluator will not register the counts . On the other hand, if a train axles passes, it shunts the track and the track relay de-energizes before the axles passes over the transducers in witch case the evaluator will register the count.

Principles of Interlocking and Standards

6

Chapter

Interlocking : Means an arrangement of signals , points and other appliances, operated from a panel or from lever frame, so interconnected by mechanical locking or electrical locking or both that their operation must take place in proper sequence to ensure safety.

Essentials of Interlocking :

- It shall not be possible to take “OFF” a running signal, unless all points including isolation are correctly set all facing points are locked and all interlocked level crossing gates are closed and locked against road traffic for the line on which the train will travel, including the overlap.
- After the signal has been taken “OFF” it shall not be possible to move any points or lock on the route including overlap and isolation, nor to release any interlocked LC gate until the signal is replaced to the “ON” position.
- It shall not be possible to take “OFF” at the same time any two fixed signals which can lead to any conflicting movements and
- Where feasible points shall be so interlocked as to avoid any conflicting movement.

ITEM	STD1®	STD 11®	STD111 ®	STD 1V ®
Allowable speed (kmph)	upto 50	upto 110	upto 140	upto 160
Isolation	Yes (not compulsory If the speed while Running through station)	yes	yes	yes
Multi aspect Signaling	MA	MA	MA	MA
Double distant	No	Yes	Yes	Yes
Point Operation	Mech	Mech/ Elec	Mech/ Elec	Elec
Point locking type	Key/ HPL/FPL	FPL/Pt m/c	FPL/ Pt m/c	Clamp
Point detection	Mech/ Elec	Mech/Elec	Mech/ Elec	elect
Locking diction	No	Yes	Yes	Yes
Interlocking	Key/ Mech	Mech/ Elec	Mech/ Elec	Elec / Elect
Track circuiting	No	for Mech inter	All Running lines Run through Lines (main line) For Elec/ Elect inter All running lines.	All Running lines
Block working	Token	Token / SGE	SGE/ T C	SGE/TC
Preventing signal Passing at danger	NO	NO	NO	YES

Electrical Lockings

Route locking:

After a route is set (that is, the points in the route are operated to the position as required for the route), it is electrically locked before the signal is cleared. By this we mean the points in the route are electrically locked and they cannot be operated for any other route till such time the route that is locked is released and the points become free for operation.

Route molding:

Once a route is set, locked and the signal is cleared for a train, it must be held till such time the train is received on the berthing track or the route is released by an emergency route release operation.

Track locking:

It is an electrical locking on a point which prevents the operation of the point when a train occupies the track circuit provided over the point.

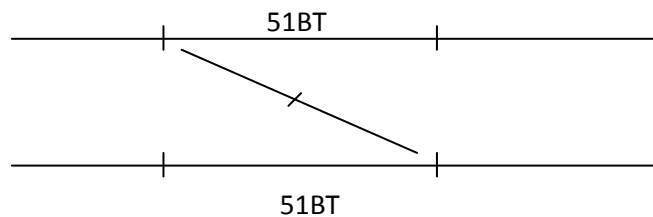

When a train is on 51 AT or 51BT, the respective track relay will be de-energized. Under this condition, it is not possible to operate the point either by route initiation or by individual operation. We say the point is track locked.

Indication locking:

It is an electrical locking so provided as to ensure that after the reception of the train on the berthing track the route is not released unless it is proved that the signal which was cleared for receiving the train has gone back to danger and all the signal control relays have de-energized.

Approach locking:

It is an electrical locking effective while a train is approaching a cleared signal and adopted to prevent releasing of the route when the train is within a “Pre-determined distance” from the signal.

For the purpose of providing approach locking on the signal, a track circuit called “Approach Track” (AT) needs to be provided to a length of 1-2 kms. (Braking distance of 1km + reaction distance of 200mts.) in rear of the signal as shown below

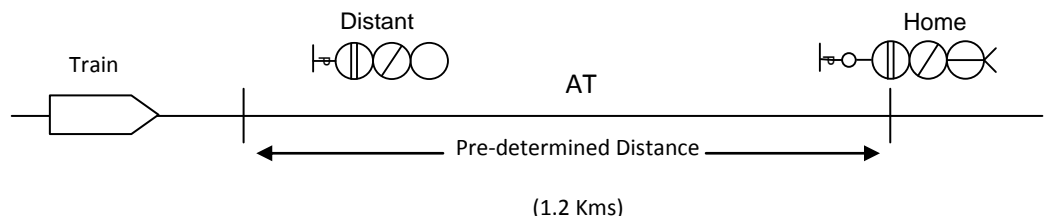

Case I : Train is beyond the pre-determined distance

Assume that the home signal is displaying the yellow aspect. The distant signal displays the green aspect. The train is beyond the pre-determined distance as shown above. And the driver has accepted the signal aspect.

If now the home signal is thrown back to danger (Red), the distant signal automatically changed its aspect from green to yellow. The driver of the approaching train on seeing the change of aspect in the distant signal will react, apply the brake and bring the train to a stop at the foot of the home signal. Therefore, immediately after throwing the home signal back to danger, the route can be released. The approach locking is not effective in this case and there is nothing unsafe also as the train is going to stop at the home signal.

Case II : Train is Within the pre-determined distance

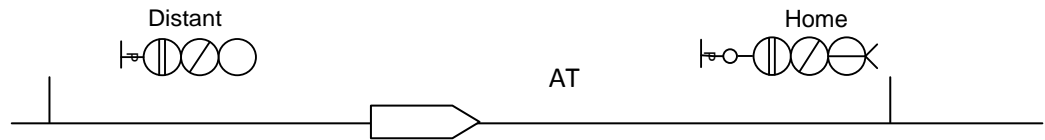

In this case, we assume that the train has come within the pre-determined distance at the time of throwing the signal back to danger. The approach track is occupied. The driver on seeing the change of aspect in the home signal to Red, immediately applies the brake. But, he may not be able to bring the train to a stop at the signal as the braking distance is not available. He may overshoot the signal. It is not safe to release the route. The approach locking becomes effective in this case and the route cannot be released.

Case II : Approach locking with time release.

Let us assume a condition when, at the time of throwing the home signal back to Red, the train has just come within the approach track. (Approach locking is effective and the route cannot be released. But, the driver is able to control the train and brings it to a stop. Now, it must be possible to release the route. Provided it is ensured that the train has stopped at the foot of the signal. Even though AT is occupied. But, how to ensure that the train has stopped? A physical verification is not possible. We depend upon a time factor to ensure this.

After putting back the signal to operator, the route release is attempted by the SM/Panel operator. The route will not be released; but a time-element relay will be switched on. After a time delay of 2 minutes, the route will be released automatically. Now, the route can be altered signal cleared and the train can be received on the altered route.

But, if the driver is not in a position to stop the train, he will pass the signal at Red. Once the train has passed the signal, the back or route locking becomes effective and the route cannot be released. The train has to be received on the route which is already set.

Dead approach locking:

It is seen that for providing approach locking, a track circuit for a length of 1,2kms. Need to be provided. Provision of such a long track circuit for the purpose of approach locking is a costly proposition. Therefore, the approach locking is provided without the approach locking becomes effective the moment the signal is cleared irrespective of the position of the train in the approach. Such an approach locking is known as “Dead approach locking”. In other words, once the signal is ‘OFF’ it gets approach locked and the route can be released (after putting back the signal to danger) only after a time delay of 2 minutes.

Back locking or route locking:

It is an electrical locking effective when a train has passed the signal and adopted to prevent releasing of the route while the train is “within the limits of the route entered”.

For any signal, the route is from the foot of the signal up to the next signal ahead. But, the limits of the route are from the foot of the signal up to and including the last point in the route. for example, for the home signal or the calling-on signal below it, the limits of the route for the purpose of back locking is from the signal up to the berthing track. The berthing track circuit shall not be included in the back locking.

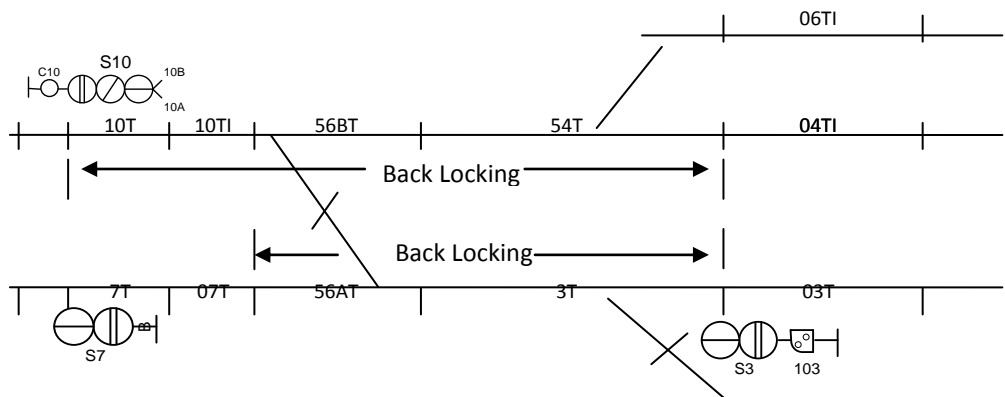

For S10 and C10, the back locking track circuits are 10T, 10T1, 56BT and 54T for both the routes 10A and 10B. So long as the train is moving over these track circuits the back locking will be effective and route cannot be released. After the train clears 54T the route will be released automatically.

For S3 and shunt 103, the back locking track circuits are 3T and 56AT.

Salient features of Relay based Interlocking

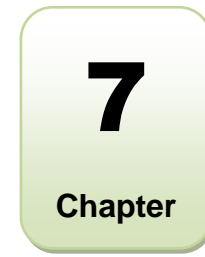

Relay Interlocking is a system of implementing principles of interlocking for safe train operations at a Station with the help of electrical circuits wired through electro-magnetic relay contacts and coils.

Difference between Route Setting Type and Non-Route Setting Type

- In Route setting type popularly known as RRI in Indian Railways (IR), no individual points need to be set. Only the route controlled by a Signal has to be initiated by pressing Entrance Button (or) Operating Entrance knob (located at the foot of the Signal on the Operating Panel) and pressing the Exit Button on the operating panel located on the track on which a Train will be received.
- In Non-route Setting type, the individual points have to be operated from the Panel by turning the Point Knob to Normal (or) Reverse as the case may be (or) pressing the Individual Point Button of the concerned Point and a Common Point Button. Then the Signal will have to be cleared by turning the Signal Knob (or) pressing the Signal Button and the Route Button.

What are the two major philosophies for Relay based interlocking used in Indian Railways?

First Type:

This uses metal to carbon contact plug in relays known popularly as Q-style relays.

Second Type:

The Second system uses metal to metal contact relays popularly known as K-50 relays. This practice is followed in many European countries. M/s. Siemens introduced this technology in Indian Railways.

What is the basic difference in the Design Approach of the two Systems i.e., one which uses Q-series Relays and another which uses K-50 relays?

- Since the relay contacts make or break current when they are closed or open, there is a possibility of metal to metal contacts getting fused or welded due to the arcing that takes place. When the make or break takes place, it is possible that even though the power supply to the coil of the relay is cut off and the relay is de-energized, due to the welding of contacts which were made during the energisation, de-energisation of the relay coil may not break the contacts. Hence, in the metal to metal contact relay design, every relay has to be proved for the back contact availability (De-energized Contact).

What is the basic difference in the Design Approach of the two Systems i.e., one which uses Q-series Relays and another which uses K-50 relays?

- Otherwise, the energized contact which is used for controlling vital operations like signalling gears may continue to be available, even though the conditions for that vital function to be operated are not fulfilled and power supply to the relay is cut off. In the metal to metal carbon contact relays because of the dissimilar material of the contacts, the possibility of fusing or welding is ruled out. Hence, this back contact proving is not required for every relay.

Parts of Sub-Systems of a Relay based Interlocking

- **Indication-cum Operation Panel:**

This panel shows the miniature lay out of the yard with controlling knobs/buttons for operating various functions mounted on the panel. This also gives indications about the status of the functions i.e., Points, Signals, Routes, Gate Control, Track Circuits, etc. This panel is operated by the Station Master who is in-charge of the Train Operations at that Station.

- **Relay Room :**

This consists of racks which are wired and on which the relays are mounted. This is the interlocking Centre of the Station. This relay room on one side is connected to the panel to receive commands from the panel for operation of the functions and also to give indication to the panel to show the status of the functions which are controlled by the interlocking. On the other side, this relay interlocking takes inputs from the field like position of signals, points, track circuits, etc., and gives output to outdoor functions to drive them.

- **Power Supply Room :**

This consists of Power Supply units as under:

- ✓ Batteries
- ✓ Battery Charges
- ✓ Voltage Stabilizers
- ✓ Transformers for Stepping down the voltages

- **Power Panel :**

This is for connecting the different sources of power i.e., Traction, Commercial Supply, Generator Supply, etc.

- **Outdoor Cable Terminations :**

Since controls originate from relay room and go to the outside functions like Points & Signals and their status are repeated to relay room, signalling cables are laid from the Relay Room to the functions.

Two-Hand Operations

1. To ensure that any Signalling gear is operated only by an authorized person, the panel has got a locking arrangement. The key is with the ASM on Duty. When he leaves the panel, he has to lock the panel and take the key with him. Once the key is out, no function can be disturbed by any outsider.

2. To ensure that only a deliberate action by the ASM operates a signal or a point and no inadvertent placing of hand on any button will lead to the operation of the function, the operation of the panel requires both the hands. In other words in the Push Button system where an accidental placing of one hand can operate the button for any function, i.e., signal or point, two buttons are to be pressed. The buttons are so placed that with a single hand, the two buttons will not be pressed.

Panel Diagram with Switches / Buttons

Conditions to be satisfied before a signal is cleared:

- a) The concerned buttons or knob has been operated by pressing or turning.
- b) The points required on the route, the overlap and isolation are set and locked correctly and route is locked.
- c) The track is clear on the Route and the Overlap.
- d) No conflicting movement is taking place or initiated already.
- e) Any level crossing gate interlocked with the signals of the Station is closed against the route traffic and locked.
- f) The crank handles controlling the points on the route, overlap and isolation are manually locked in the proper place and not available for taking to the site of the points.
- g) Any siding connected to the track on which the movement will take place is set to the correct position to facilitate the signal movement and locked.
- h) If it is the last stop signal, line clear is already obtained from next station.

Power Supply Requirements :

1. Battery for operating the relays in the relay room.
2. 24 V DC for Q-series relays.
3. 60 V DC for K-50 relays of Siemens.
4. Battery for extending feed to the outdoor relays.
5. 24 V battery for panel indications.
6. 110 V battery for operating the points.
7. 110 V AC (stabilized) for colour light / LED signals.
8. 110 V AC for feeding battery charger to track feed batteries for track circuits.
9. Transformers for stepping down 230 V AC to 110 V DC.

10. Battery chargers (230 V AC) for various battery banks.

OR

11. 110 V Battery with IPS (Integrated Power Supply)

Types Of Signalling Cables Used

1. **Outdoor Cables** : Multi core copper conductor with PVC insulation, PVC sheath and steel armouring.

Size of conductor : 1.5 or 1.6 sq. mm.

No. of Cores : 6, 8, 10, 12, 16, 20 and 30.

2. **Indoor Cables** : For the internal wiring of relay in locations and cabin.

The cable is with plain annealed copper conductor PVC insulated, unarmoured flame retarding type.

Flexible multi strand wire size 3 / 0.75 mm.

Flexible insulated wire size 16 / 0.20 mm.

Multi core each core of size 1 mm.

Multi core each core of size 0.6 mm.

(Multi core is either 40 or 60 cores)

Single core size - 1 mm.

Outdoor Equipments

1. Point Machines
2. Colour Light or LED Signals.
3. Relays, batteries, chargers, transformers located in location boxes.
4. Track circuits.
5. Axle Counter ground devices (the evaluator taking inputs from ground devices is located generally in the relay room or in a separate room in the building housing the relays. The ground devices are connected to the evaluator through quad copper cable with polythene insulation.)

Stages in Installation and Commissioning of Relay Interlocking System at a Station

1. Preparation of the permanent way plan by Civil Engineering Department showing the position of track, point, station building, distance of adjacent station, kilometer of the station etc.
2. P-Way plan is examined by the signal department for the suitability of the signalling and then approved.
3. Preparation of signalling plan showing the location of signals, numbering of points and signals, location of the panel room and relay room, interlocked gates within the station section etc.
4. Preparation of selection / control table showing the conditions to be fulfilled for each signal movement with the associated interlocking needed, track circuits to be proved etc.
5. Design of the circuits based on the selection / control table.
6. Preparation of wiring diagram based on the circuit diagram approved, contact analysis of relays and marking contact numbers, repeater relays etc.
7. Installation of relay racks and wiring of the racks as per approved wiring diagram.
8. Testing of the actual wiring done.
9. Installation of power supply equipment, completion of outdoor works like track circuits, signals, fixing of point machines etc.
10. Conducting simulation test.
11. Commissioning by connecting indoor equipment to outdoor equipment after final testing.

Button Description and Button Nomenclature

Individual Button Description

- GN - Signal Button Red
- UN - Exit or Route Button White or Grey
- WN - Individual Point Button Black
- NWWN - Common Normal Point Button Black with red dot

- RWWN - Common Reverse Point Button Black with red dot
- EWN - Emergency Point Operation Button Blue with red dot
- COGGN - Common Calling-on Signal Button Red with white dot
- EUYN - Emergency Route cancellation Button Red with white dot
- RRBUN - Super emergency route cancellation Button Red with White dot
- GBN - Group Slot Release Button Blue
- GRN - Group Slot restoration Button Blue
- EOVN - Emergency Overlap Release Button Red with white dot
- EGGN - Emergency Signal Cancellation Button RED
- G-31 N - Gate Button Brown
- RRBUSN - Emergency Route Release Signal Key to be operated by Signal Staff

Counters provided on the Panel

- COGGN - For recording Calling-on Signal operation
- EOVN - For recording Overlap Emergency Cancellation
- EWN - For recording Emergency operation of points under Track Circuit failure
- EGGN - For recording emergency cancellation of signal
- RRBUNR - For recording route cancellation under emergency with track circuit failure
- EUYN - For recording route cancellation under emergency without track circuit failure
- Emergency/Normal Crank Handle Counter For recording crank handle extraction

Buttons to be pressed for various operations

- To clear a Main or Shunt Signal: GN + UN
- To clear a Calling-on Signal: Calling-on GN + COGGN. Then leave COGGN, press UN
- To put any signal to ON: GN +EGGN
- To operate a point with no track circuit failure: Individual WN +{NWWN or RWWN}, depending on need to take it to N or R.
- To operate a point under track circuit failure: {NWWN or RWWN} + EWN. Then leave EWN and press individual WN.
- To give control to L.C. gate to open: Gate button + GBN
- To take control back from L.C.: Gate Button + GRN
- To release a route after putting the signal to 'ON' by pressing GN + EGGN if track circuits are functioning normal.
- GN + EUYN Then after 2 minutes ALSR will pick up. OVSR will pick up thro ALSR front contact. Thus Route and Overlap get released.
- To release a route that does not get unlocked after the train has arrived due to track circuit failure..
- Signal staff has to insert their key in the panel and turn. Then GN + RRBUN will be pressed by ASM. After 2 minutes ALSR will pick up. OVSR will pick up thro' ALSR front contact. Thus Route and Overlap get released.
- To release overlap manually, if does not get released after the arrival of the train.
- Press GN + EOVN. After 2 minutes overlap will be released.
- To release a crank handle for manual operation of point: Press concerned point CH N + GBN
- To take the control of crank handle: Press CH N + GRN

Audible Alarms

- Any Button stuck alarm.
- Any point or signal failure alarm.
- To stop the alarm, ASM has to press an Acknowledge button. But visual failure indication will continue, till failure is attended and cleared.

Indications on the Panel

- Point position indication i.e., Normal or Reverse.
- Signal aspect indication i.e., red or yellow or green or double yellow.
- Route set and locked indication.
- Track occupied indication.
- L.C.Gate indication i.e., closed or open.
- Crank handle position: in or out, free or not free.
- SM's Key in or out.
- Point locked or free.
- Which group button has got stuck? i.e., signal/point/common button

Block Indications

- Line clear
- Train passing Advanced starter
- Auto-TOL
- Block section clear

Sequence operation of relays for signal clearance (Refer Fig. 7.02).

- SM's Key is in and GN + UN buttons are pressed.

Relays that pickup

- SMR, GNR, UNR
- LR
- NWR or RWR
- NWPR or RWPR
- NWKR or RWKR
- UCR
- ALSR,OVSR,WLR

Relays that drop

- RWR or NWR
- RWKR or NWKR

Relays that pick up

- UHR,UECR
- HR
- HECR
- **Train passes signal**
- RECR,TSR1
- TSR2 etc., TSSLR
- Train clears last point and fully arrives on berth track.

Relays that drop

- RECR
- Track relay
- TSR,LR,UCR,HR,HECR

Sequence of relay operation

Relays that pick up

- TRs, ALSR
- With time delay OVSR
- TSR,WLR

Relays that drop

TSR1,TSR2 etc., TSSLR

SCHEMATIC DIAGRAM FOR RELAY INTERLOCKED STATION

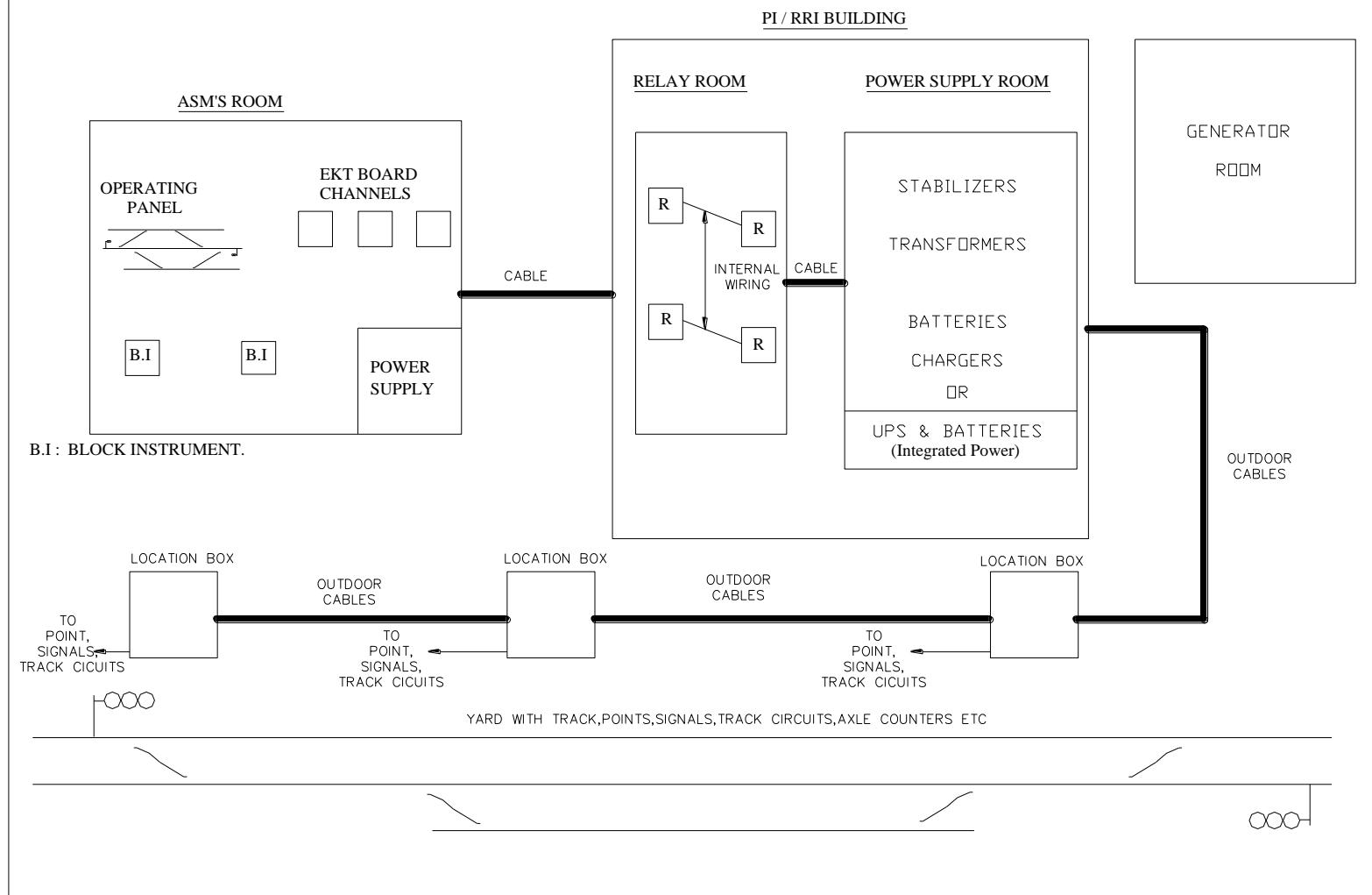

Fig – 7.01 – Schematic Diagram for Relay Interlocked Station

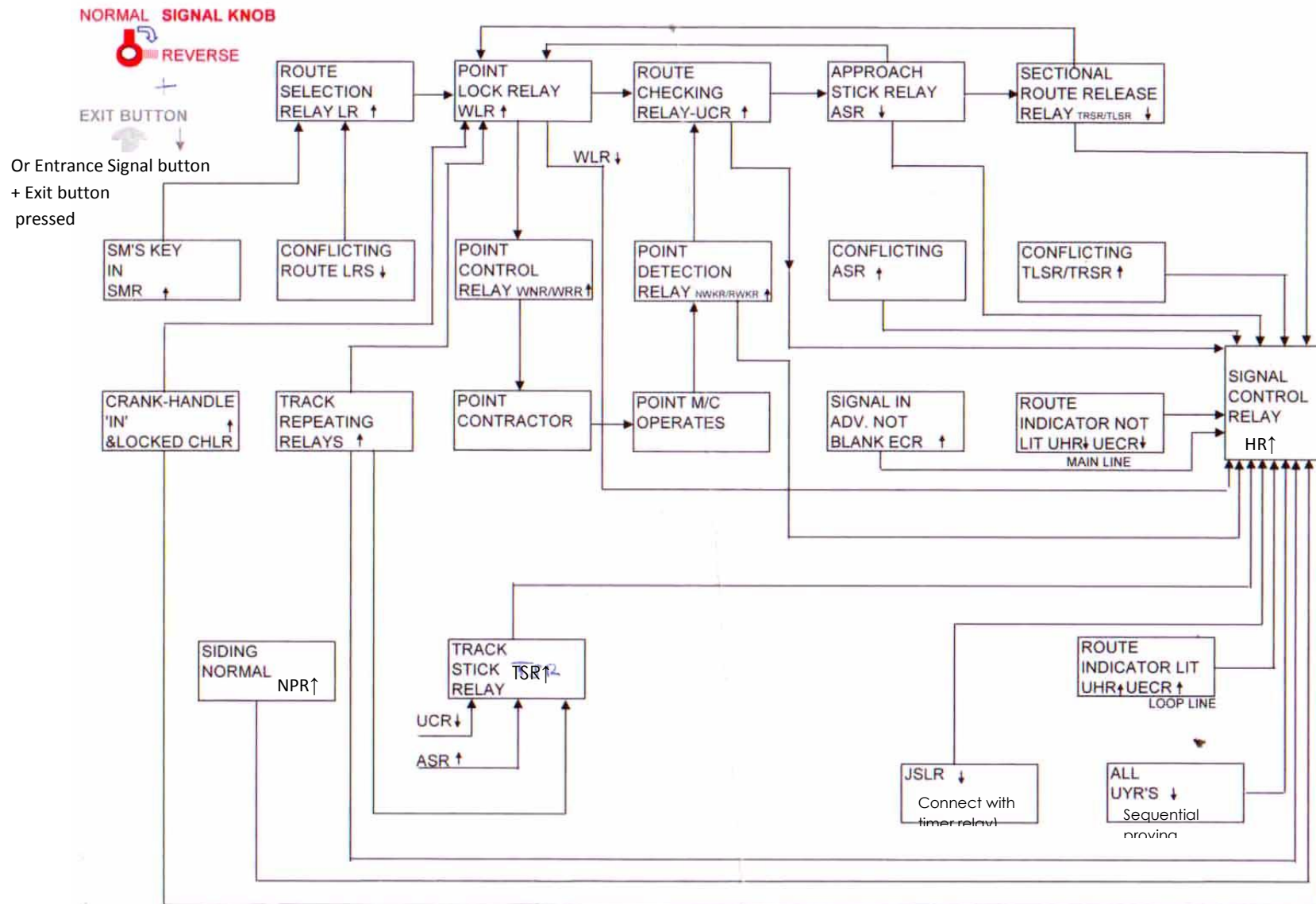
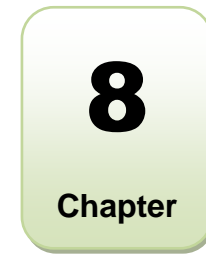

Fig – 7.02 – Relay Sequence Chart

Selection Table



In the relay interlocking systems, the safety of train movements in the yard has to be ensured in the various electrical signaling circuits that are prepared for the system. The circuits therefore have to be prepared care fully and meticulously and checked thoroughly from the point of view of safety .As it will be cumbersome to prepare the signaling circuits directly from the signal interlocking plan (SIP). The various safety aspects such as interlocking of conflicting routes, requirements of points for each route, the track circuit controls for the points, the route holding requirements such as approach locking and back or route locking and other controls such as crank handle controls, gate controls, block control and overlap release etc. are first put in a table called “**control table.**” Or “**selection table**” and this table is used in the preparation of circuits.

A 2 tier or even 3-tier checking of the control table is done for the correctness and approved by the approving authority before it is translated into circuits.

The control table is also very much useful at the time of testing the installation before commissioning.

The various columns of the control table are shown in the sheet attached.

In the preparation of the control table, the following points should be kept in view:

When a route is set and locked, it should lock all other conflicting route may be.

- A. **Directly conflicting route:** Route which require all its points in the same position as that of the route which is set and locked.
- B. **Indirectly conflicting route:** Route which require at least one of its points in a different setting from the points of the route which is set and locked.

1. The interlocking between indirectly conflicting route is automatically achieved through the points /points as the point set and locked in one position, say normal for the route set will not be available for the conflicting route which require the point in the reverse position, and therefore, the conflicting route can not be set. For directly conflicting routes, as all the points are required in the same position and are already set, the interlocking can not be achieved through the points. The interlocking has to be specifically provided in the circuits and the same has to be indicated in the control table under the column "Locks signal routes".

2. The following points has to be kept in mind for at the time of providing the interlockings:
 - a. A main signal shall lock the shunt signal ahead and vice-versa.
 - b. A main signal shall lock the shunt signal below it and vice versa.
 - c. A main signal shall lock the calling on signal below it and vice versa.
 - d. A calling on signal shall lock the main and shunt signal ahead and vice versa.
 - e. A calling on signal cleared from the main line shall lock the advanced starter of the same direction and vice versa.
 - f. Starter signal at either end of the berthing track shall lock each other.
 - g. Shunt signal at either end of the berthing track shall lock each other.
 - h. A Shunt signal and a main signal at either end if the berthing track shall lock each other.
 - i. Conditional locking shall be provided wherever necessary.All the above interlockings have to be shown in column "lock signal route "of the control table.

3. The requirements of points, normal or reverse as the case may be, for each route and their detection have to be shown in respective columns of the control table .The point control circuits have to be prepared as per the requirements of the points for the route and their detections have to be proved in the route checking and signal control circuits.

4. Before clearing a signal, the route should be clear of any obstruction including the overlap. This is achieved by proving the clearance of track circuits from the foot of the signal upto the next signal, and the overlap track circuits beyond it. All these track circuits have to be shown in the column “controlled by track circuits” and have to be proved in the signal control relay circuits.
5. Other controls such as “crank handle control” “siding point control “, ”gate control “ etc., have also to be shown in the respective columns of the control table and incorporated in the appropriate control circuits.
6. After the signal is cleared ensuring all the above said safety conditions, the route must be held when the train approaching the signal as well as when the train has passed the signal till such time is clears the last point in the route. The former is achieved by providing approach locking on the signal. For the home signal, as there will be no long approach track circuits for this purpose ,dead approach locking is provided..This is shown in the “Approach locked by track circuit column as “dead approach” or as “signal off” which means that the approach locking will be effective once the signal is taken off and can be released only after the time delay of 2 minutes. For other signals, this can be provided with the help of track circuits. Already available in the rear of the signal or dead approach can be provided.
7. Once a train passes the signal, the route is held by providing back or route locking. The track circuits from the signal up to the last point in the route which are used for this purpose are shown in the column ”Back locked by track circuits “are proved in route release circuit. So long as the train is passing over these track circuits, the route cannot be released.
8. The overlap is released 2 minutes after the train has occupied the berthing track or after the overlap track circuits are cleared by a run-through train. These track circuits are shown in the control table under the column “overlap releases”

9. Once the train passes through the signal, the signal is immediately replaced to "ON" by occupation of the first track circuit after the signal. This comes under the column "signal replaced by track circuit occupied"
10. The selections for the calling on signal are the same as those of the signal above it except that the calling on signal will not be controlled by any track circuit other than the first track circuit after the signal as a calling-on signal can be cleared even if any track circuit in its route fails or the berthing track is occupied. The first track is included in the control only to put back the signal to "ON". It must be noted that for the calling on signal, no overlap is set and as much the overlap points will not figure in the points column. The fact that the calling on signal will clear only after 2 minutes of occupation of the calling on track in rear of the signal is indicated in the "Remarks" column. Even though overlap points positions and the overlap track circuits are not provided for clearing the calling-on signal, shunting or any other movement in the overlap portion is prohibited in the interest of safety.
11. For Shunt signal, the selection is the same as those of main signals. No overlap is required for shunt signal movements. Therefore, overlap point positions and detections are not shown against shunt signal routes.
12. There is no route as such for the last stop signal. It is controlled by the block instruments of the section which is shown in the "remarks" column. The short 2 rail length track circuit after the LSS is shown in the controlled by track circuits column.

Points control table

The route wise control table does not show the points controlled. Each point is controlled by the point track circuits for track locking so that if any train is moving over the points, the track locking will be effective and the points cannot be operated under the wheels. This aspect is illustrated separately in a points controlled table. This table includes columns showing the routes which lock the points in normal position and in the reverse and also the crank handle controls. This facilitates a cross-checking with that provided in the route wise control table and also used at the time of testing before commissioning. The point control table for the yard under study is placed.

Nayagon Mini Yard Plan

Nayagon Selection Table

Nayagon Selection Table

Nayagon Selection Table

Nayagon Selection Table

Nayagon Selection Table

Nayagon Selection Table

Points control table

Sl. No	Point No	Track locked by track circuits	Signal routes locking the points in		Overlaps locking the points in		CH Control
			Normal	Reverse	Normal	Reverse	
1	51	4T.51/53T	1A.1B.C1A.C1B, 4.6.104.106. 201.204	8.108.10C.201	4/6B/8	4/6B/8	CH1
2	52	4T.6T	4.104 (201W51N)	6.106. (201W51N)	4/6B/8.6A	4/6B/8	CH2
3	53	51/53T	1A.C1A.204. (201W51R)	1B.C1B.8.108. (201W51R)	-	4/6/8	CH3
4	54	54T	10A.C-10A.10C. C- 10C	10B.10B-ALT. C- 10B	-	-	CH4
5	J55	3T.5T	3.103.202	5.105.202.10C. C-10C	3/5B.5A	3/5B	CH5
6	56	56AT.56BT	10A.C+10A. 10B.10-ALT. C- 10B.3.5.103.105. 202.	10C.C-10C	3/5B	-	CH6

Explanation of Circuits

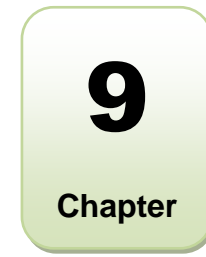

9.1 button relay circuits

We have studied in Chapter No.7, the various features provided in the “Control cum Indication Panel”. Every main and shunt signal has a button provided at the foot of the signal symbol on the panel. The route buttons are provided in the middle of the track configuration for each route. These buttons are also known as exit buttons or destinations buttons. Point buttons are provided at the point configuration. The various common buttons such as WWN, EWN, EGGN etc. are fixed on the top of the panel. All these buttons are differently colored for easy distinction.

Each button has a button relay. Whenever a button is pressed, the button relay is energized and remains energized till the button is released and restored back to its normal position. In case the pressing of the button is prolonged or the button fails to restore, a failure indication will appear on the panel. The various buttons are grouped as follows and the button relay circuits are provided accordingly:

- 1 Signal button relays
- 2 Route button relays
- 3 Point button relays
- 4 Common button relays

9.1.1 Design Principles

- 1 The button relays circuits are so designed that only one button relay of that kind can energize at a time. This simplifies the interlocking.
- 2 Each button relay circuits will have a “common buttons normal checking relay (NCR)” which is normally energized proving the back contacts of all the button relays of that group.

- 3 The Station Master Control (SMR) is provided on all the groups excepting the signal button relays group-. This is so to enable putting back the signal back to danger in case of emergency by any person in the absence of the SM.

9.1.2 Signal button relay Circuits (Drg.No.9.1.01)

It may see that whenever any signal button is pressed, the concerned button relay picks up. The circuit is so designed that any button relay picks up only if all other button relays are de energized.

The common signal buttons normal checking relay (GNCR) is normally energized proving the back contacts of all the signal button relays. It is a slow to release relay by about 5 to 7 seconds so that during normal operation of the button and its release, the GNCR does not drop and give any false indication of failure. In case the panel operator prolongs the operation of the button beyond this time, this relay drops and gives a bell warning forcing the operator to release the button. In case the button fails to restore or the button relay fails to de-energize, GNCR drops and gives a visual failure indication as well as a bell warning to attract the attention of the panel operator to the failure. The bell warning is stopped by pressing an ACK. Button, while the visual indication persists till the failure is rectified.

The relay is made slow to release with the help of the 3000MFD capacitor and a 100 Ω protective resistance connected across the relay.

It may be seen that in this circuit the SMR control is not provided for the reason already mentioned.

9.1.3 Route button relay circuits (Drg.No.9.1.02)

The circuit is similar to GNR circuits. Any route button relay can be operated only by an authorized person namely Station Master or Panel Operator. The buttons normal checking relay in this case is UNCR, which is a slow to release relay as GNCR and its function is the same as that of GNCR.

9.1.4 Point button relay circuits (Drg.No.9.1.03)

The design of the circuit is similar to route button relay circuits. Here also the authorized operation is ensured by SMR relay. The button normal checking relay is called as WNCR which does the same function as that of GNCR and UNCR. The crank-handle button relays are also grouped and their circuits designed on similar lines. The NWWN, RWWN and EWN button relays are also shown and the circuits are self explanatory.

9.1.5 Common button relay circuit (Drg.No.9.1.04)

The following common buttons for the entire station are grouped in this circuit.

- a) CO GGN - Calling on signal button
- b) EUYN - Emergency Route Release button.
- c) RRBUN - Super Emergency Route Release Button
- d) GRN - Common (General) Slot Return button.
- e) GBN - Common (General) Slot button
- f) EOVN - Emergency overlap Release button.

Here again only one button relay can energize at a time and can be operated only by an authorized person (SMR)

The emergency signal cancellation button (EGGN) is a press to break contact unlike the other buttons which are press to make type. Through the normally closed (NC) contact of the button, EGGNR remains normally energized. There is no SM's control of this relay as this relay is required to throw the signal to danger in case of emergency by any person.

With the "SM's Key-in", SMR relay is normally energized, enabling the various operations on the panel. The super emergency route is release done by the SM, only with the cooperation of the signal staff. For this purpose, an RRBU lock is provided on the panel and the key for this lock will be in the custody of the signal staff of the station. Whenever super emergency route release is to be performed, the signal staff has to put his key in RRBU lock and turn it. The RRBUSNR relay picks up and if the SM presses the RRBUN button, RRBUNR picks up through the front contact of RRBUSNR and enables the route to be released.

Fig. 9.1-01

(A3 Size)

Fig. 9.1-02

(A3 Size)

Fig. 9.1-03

(A3 Size)

Fig. 9.1-04

(A3 Size)

9.2 Route Selection

The energisation of GNR & UNR energizes the route selection relay (LR), provided that no conflicting route is set. Thus the basic interlocking is ensured at this first stage itself.

- LR is designated after the signal number & with route alphabet, if the signal has more than one route.
- LR is normally down & picks up when an operation to clear a signal is performed & when the interlocking permits.
- LR picks up only when the conflicting LR's are not energized.
- Energization of LR operates the points to the desired position..
- LR front contact is used in route checking (UCR) & signal control (HR) circuits.

Now let us consider energization of 10ALR. Refer Fig. No. 9.2-01

B24, fuse, 10/C-10TSR↑ C-10ALR↓ C-10BLR↓ C-10CLR↓ C-10ALSR↑ 56WLP1↑
10-CLR↓ 10-BLR↓ 201ALR↓ 201BLR↓ 201CLR↓ 201DLR↓ 201ALSPR1↑ 51WLR↑
8LR↓ 104LR↓ 106LR↓ 108LR↓ 204LR↓ 104/106ALSR↑ 10B-ALTLR↓ 6LR↓ 54WLR↑
52WLR↑ 10GNR↑ D-4UNR↑ 10ALR EGGNR↑ N24

Once 10ALR picks up it sticks through its own front contact by passing the front contacts of 10GNR and D-4UNR as these relays will drop when the buttons are released. 10ALR should remain energized till such time the train passes the home signal 10 and occupies the first track circuit 10T when 10/C-10 TSR drops and cuts off the feed to 10ALR.

After setting the route and clearing the signal, if it is desired to cancel the signal by pressing 10GN and EGGN, 10 GNR picks up and EGGNR drops with the result N24 is cut off from 1ALR and the relay drops and is normalized.

After 1ALR picks up, it sets the route. Points 51, 52, 54 and 56 are set in their normal position and their WLRs de-energize and lock the points in the route. The front contact of the WLR of these points proved in the circuit will cause de-energization of the 1ALR relay. To avoid this contingency, the WLR front contacts of these points are by passed with the front contact of the respective NWKRs and the feed of 1ALR is maintained through these contacts.

The circuits of 10BLR and 10B-ALT, LR are also given in this drawing to study and understand the principles involved in the design of these circuits.

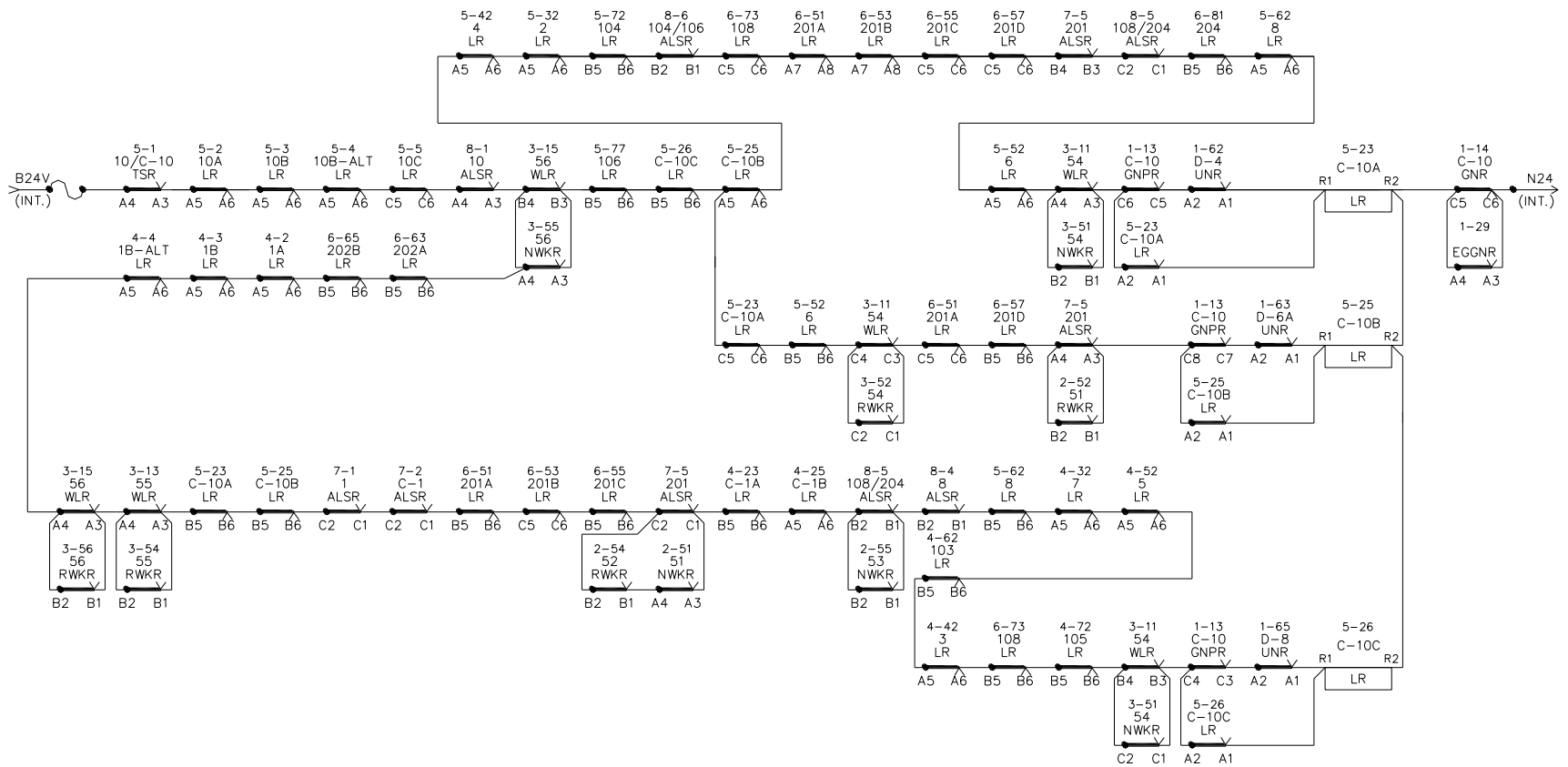

Fig – 9.2.01 – Calling-on Signal LR Circuit

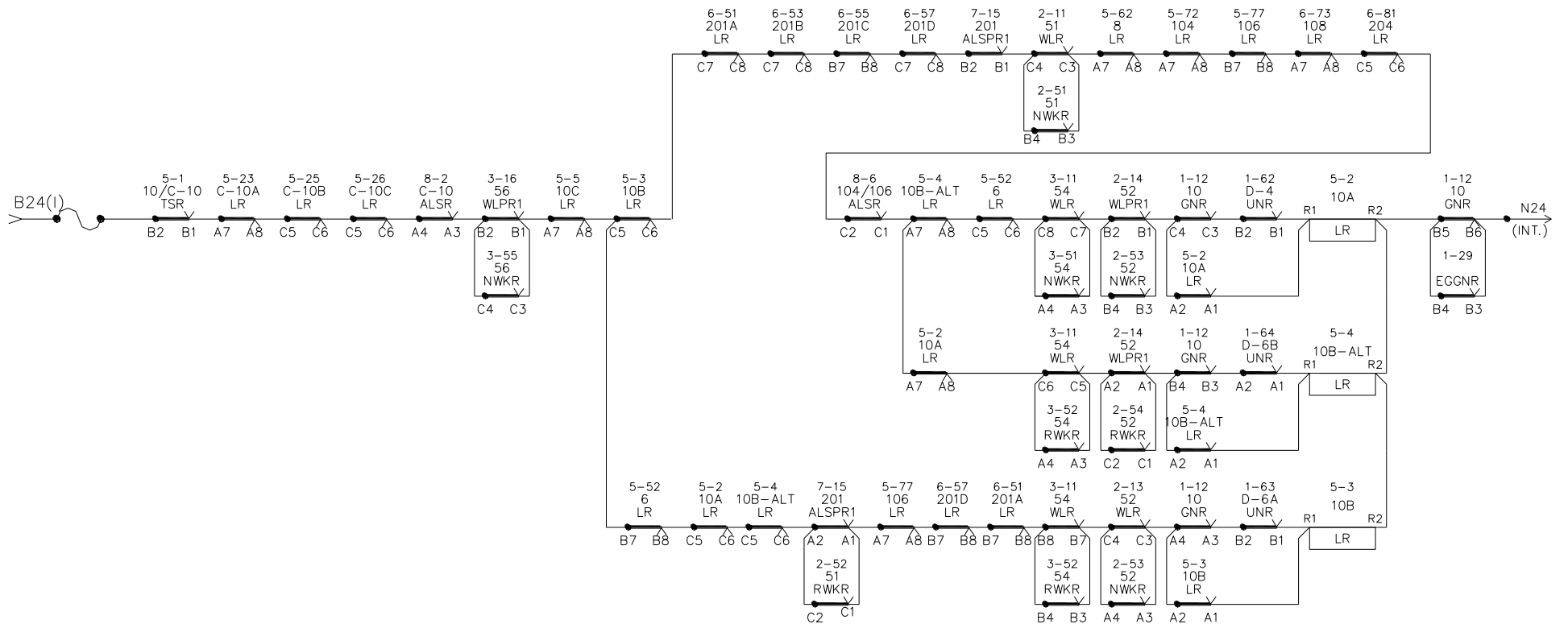

Fig – 9.2.02 – Home Signal LR Circuit

9.3 Point Operation

Circuit Explanation:

Let us take point no.51 for discussions.

A point can be operated from normal to reverse or vice versa, as per requirement by any one of the following methods:

1. As a part of route setting for a signal that needs to be cleared.
2. Individual operation of point under normal condition (i.e., Track Circuit Controlling the point is energized).
3. Individual operation of point when track circuit has failed to energize.

Let us see each of the above operation

1. Under route settings, we want to clear the signal 201 to UP main line. So we press 201GN+D-3 UN buttons.

201BLR operates (route setting relay for 201B route) Every point has 2 relays called NLR & RLR

NLR – Relay to take the point to Normal

RLR – Relay to take the point to Reverse.

Normally NLR↓ RLR↓

NLR or RLR picks up in response to any particular LR (route selection relay), if the route has the point for that signal.

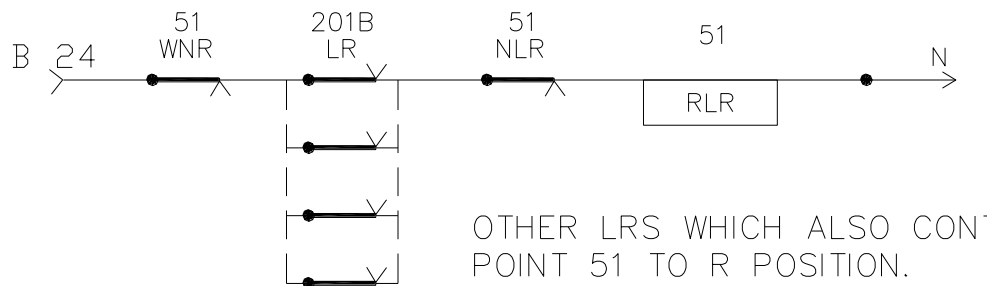

Fig. 9.3 - 01

51WNR↓ proves point button is not pressed. No. individual operation

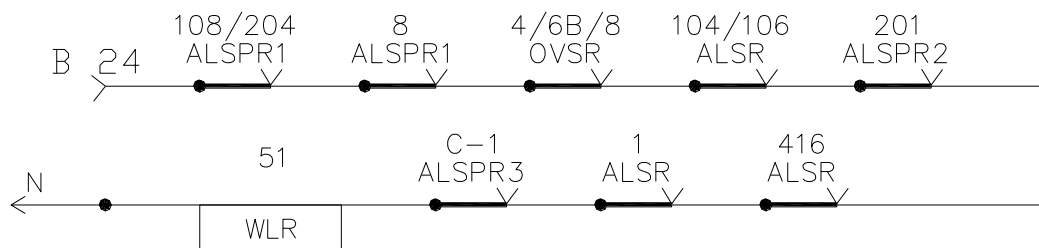

Fig. 9.3 - 02

WLR is the point locking relay.

WLR↑ proves point in free to be operated.

51 point falls under the routes of

108	↑ Signals	Point 51 falls under the overlap of these signals reckoned beyond starters	
204		Signal No.	Starter No (OVSR)
8	↓	10	4
104			8
106			6 (set for main line)
201			
4			
6			
1			
C			

So their ALSR ↑ is proved in WLR circuit to establish the fact that no signal movement is taking place on this point no51. For overlaps, OVSR is proved, as overlap point is free when OVSR↑

Point Operation : Assume point 51 is normal.

So 51NWKR↑ Point normal controlling relay is energized, i.e, 51NWR↑

All other relays namely 51RWKR, 51RWR, 51NWPR, 51RWPR, 51WJR are de-energized. WJR is a relay which limits the operation time of point machine to 10 seconds to prevent overloading.

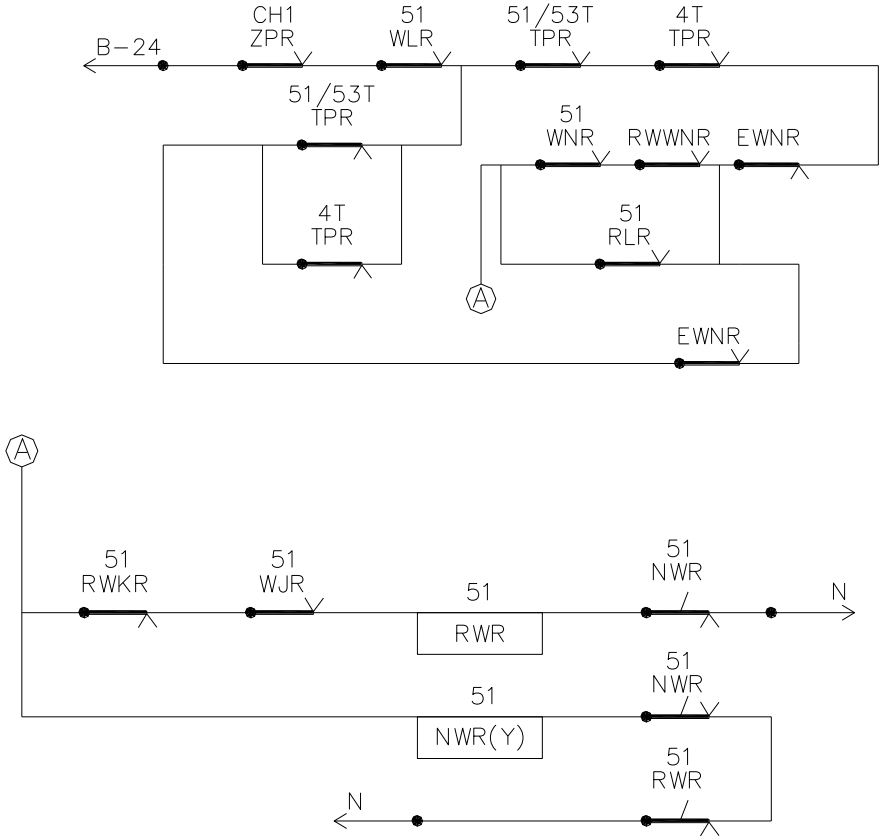

Fig. 9.3 - 03

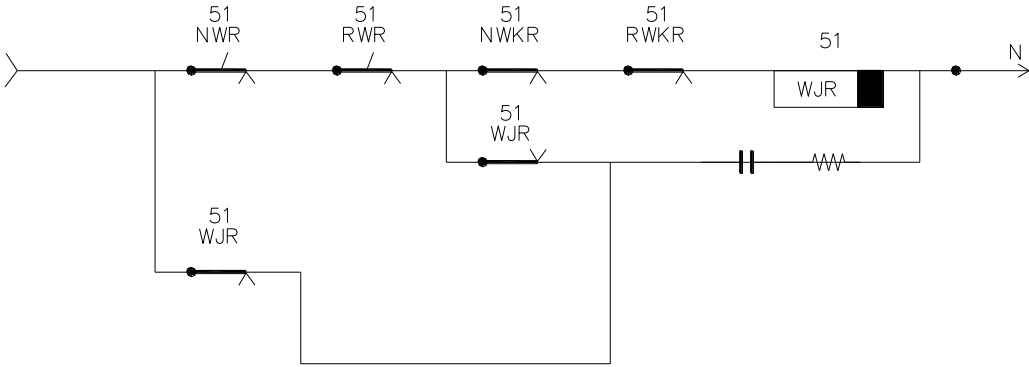

Fig. 9.3 - 04

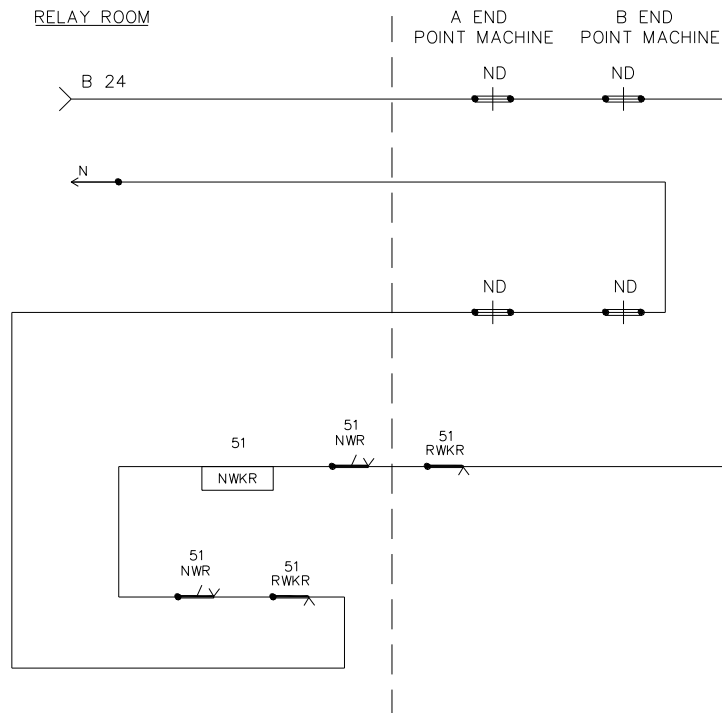

Fig. 9.3 - 05

Circuit Explanation

Fig 9.3-03 As soon as RLR \uparrow , after proving crank handle is locked inside the ASM's office (i.e., not available for operation of the point), point is free from Signal locking & track circuits are energized, current flows through NWR(Y) i.e. release coil. So NWR \downarrow , circuit to NWR(Y) is cut off by NWR front contact breaking.

- CH1 ZPR \uparrow - Crank handle is locked
- WLR \uparrow - point is free from signal locking
- TPR \uparrow - Track locking is free
- EWNR \downarrow - no emergency operation of point
- RLR \uparrow - route requires point to go to reverse

Fig 9.3-05 This is the normal detection circuit. NWKR \uparrow proves point controlling relay is normal (NWR \uparrow) & point is normal (ND contacts are available)

When NWR \downarrow as per Fig 9.3-03, NWKR \downarrow Now with NWR \downarrow , NWKR \downarrow , RWR & RWKR are already in dropped state, WJR picks up (Fig 9.3-04). It will be in energized state for a maximum of 10 seconds or till point goes to reverse & RWKR picks up.

Once WJR \uparrow , the resistance / conductor cannot get connected to mains 24v to get charged.

Please refer to Fig 9.3-03 again

As soon as WJR \uparrow , 51RWR picks up & gets latched, as 51RWR is a QL relay (magnetically latched) 51 RWR coil picks up proves NWR \downarrow Once RWR \uparrow , WJR feed is cut off from 24V, but it holds through its feed from resistance (Condenser) in a loop.

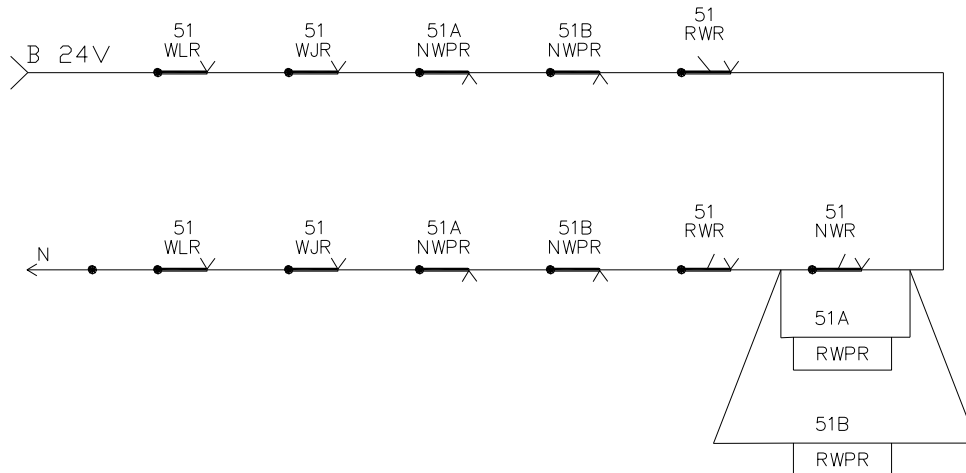

Fig. 9.3 - 06

Fig 9.3-06 shows the circuit for 51A RWPR, 51 BRWPR, RWPR controls power (heavy duty contact relay) to the point machine. ARWPR is for A end machine, BRWPR is for B end machine.

REVERSE POINT OPERATION

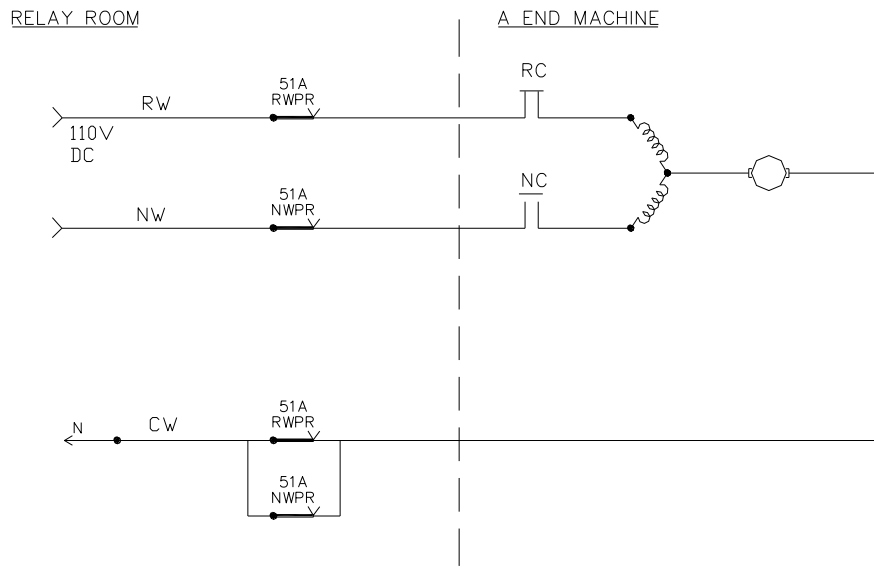

Fig. 9.3 - 07

REVERSE POINT OPERATION

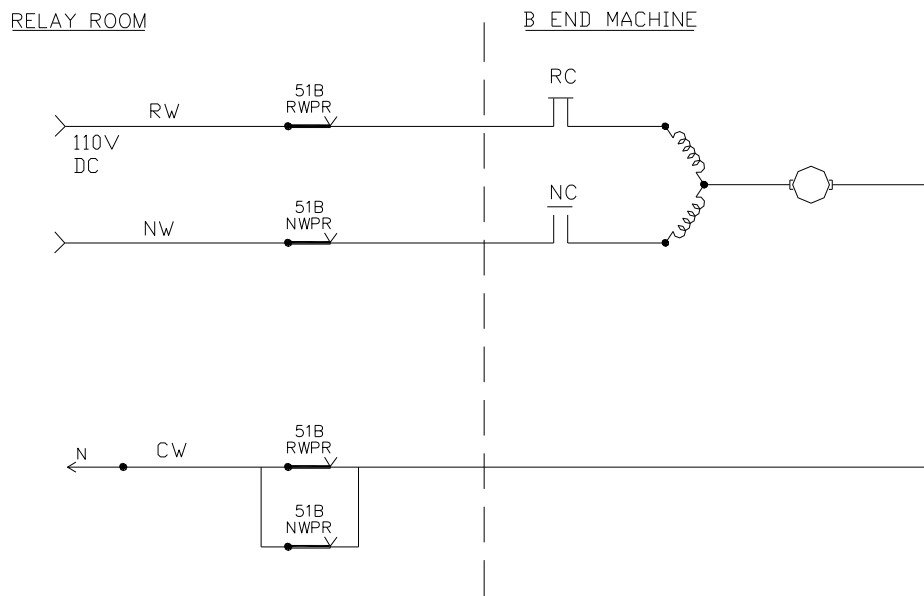

Fig. 9.3 - 08

(Note : As point is normal. RC is made & NC is not made)

Normally NWPR↓ RWPR↓ now RWPR↑

So A & B ends get 110V DC

So motors operate. ND breaks

When the point is correctly set to reverse RC breaks, current is cut off. NC is only made

Assume that point get correctly set to R

RD contacts in both machines make

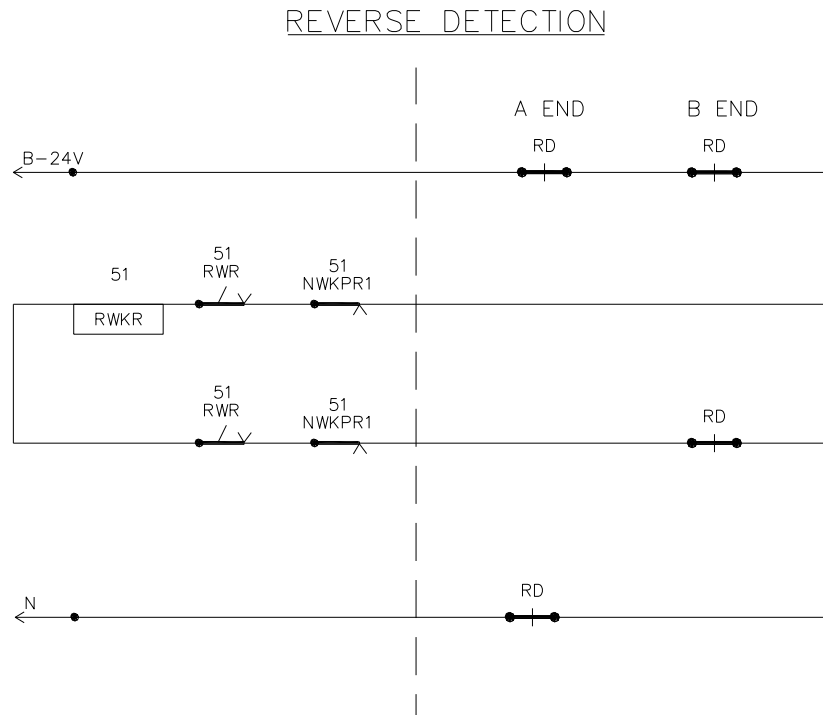

Fig. 9.3 - 09

Once RWKR↑, WJR feed is cut off, refer (Fig.9.3-04).

WJR dropping, RWPR drops. So 110V DC is cut off to the machine.

If the RWKR does not make within 10 seconds,

WJR will drop due to loss of charge on condenser.

Please see sheet 9 to 12 of Circuits of Nayagaon and learn how point moves to Normal from reverse.

Individual operation of points :

Condition 1 :

Track circuit is normal. Press 51WN and 51RWWN to take the point to reverse.

Here RLR will not pickup, as RLR picks up thro LR only & not through point buttons.

So NWR will be released first.

See that particular branch where RLR↑ is bye-passed by WNR↑ + RWWNR↑

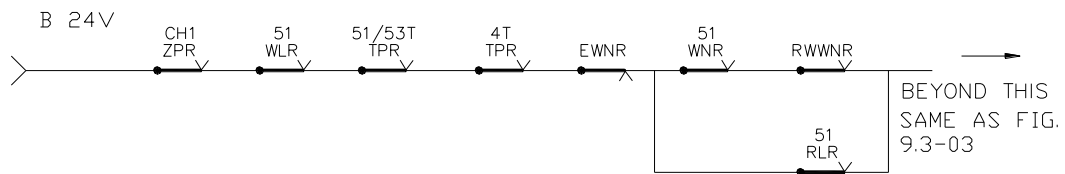

Fig. 9.3 - 10

Here NWR release circuit is through WNR↑ RWWNR↑ and not through RLR↑ rest all are same.

Condition 2 :

Track circuit has failed

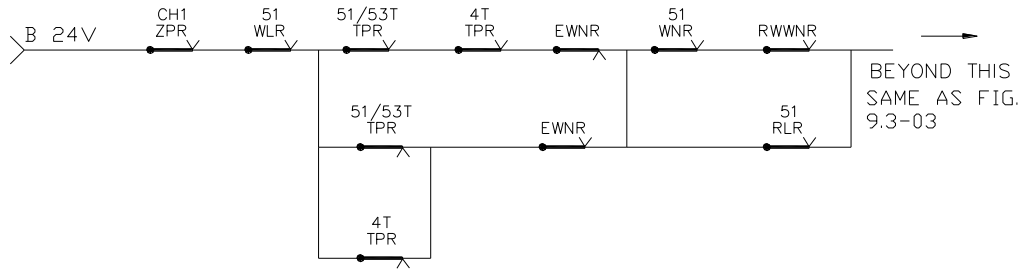

Fig. 9.3 - 11

Here RLR↓, one of the track circuits or both are de-energized. So thro EWN[↑] only circuit for point operation will work.

So press EWN + RWWN first – so EWN[↑], RWWN[↑]

Now leaving EWN button only, press 51WN. 51WNR[↑]

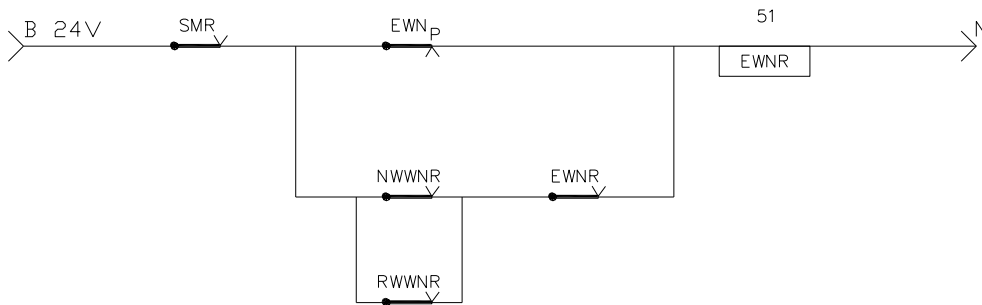

Fig. 9.3 - 12

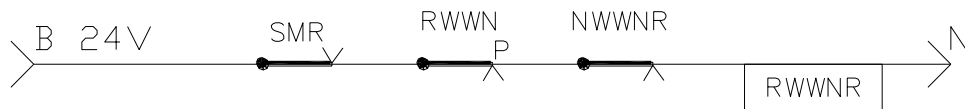

Fig. 9.3 - 13

9.4 Route Checking Relay – UCR

- The route checking relay (UCR) checks that all the points involved in the selected route are correctly set and locked at the site. It also proves that the route set is for the signal route initiated including isolation and overlap.
- One signal will have one UCR & will be designated by the signal number.
- It will have parallel paths depending upon the number of routes to which the signal leads.
- UCR is normally down.
- UCR front contact will be proved in HR CKt.
- UCR back contact will be proved in ASR ckt.

UCR circuit should provide for,

1. Conflicting UCRs down
2. NWKR/RWKR of points on the route
3. Crank handles of points in the route are locked
4. Level-crossing if any, are closed and locked against the road traffic.
5. LR for the route initiated. – Preferably with double cutting.

Now let us see how 10 UCR picks up full-filling the above conditions for 10A route Refer Drg.No 9.4-01. B24, fuse, G-31 KNLPR \uparrow CH6ZPR \uparrow CH4ZPR \uparrow 56NWKPR2 \uparrow CH2ZPR \uparrow 51NWKPR3 \uparrow CH1ZPR \uparrow 54NWKPR \uparrow 52NWKPR2 \uparrow 104UCR \downarrow 10A LPR1 \uparrow C-10UCR \downarrow 201UCPR1 \downarrow 10UCR (coil) 10ALR \uparrow N24

Similarly if any other route of signal No.10 set, the same UCR relay picks up proving the correct setting of the route.

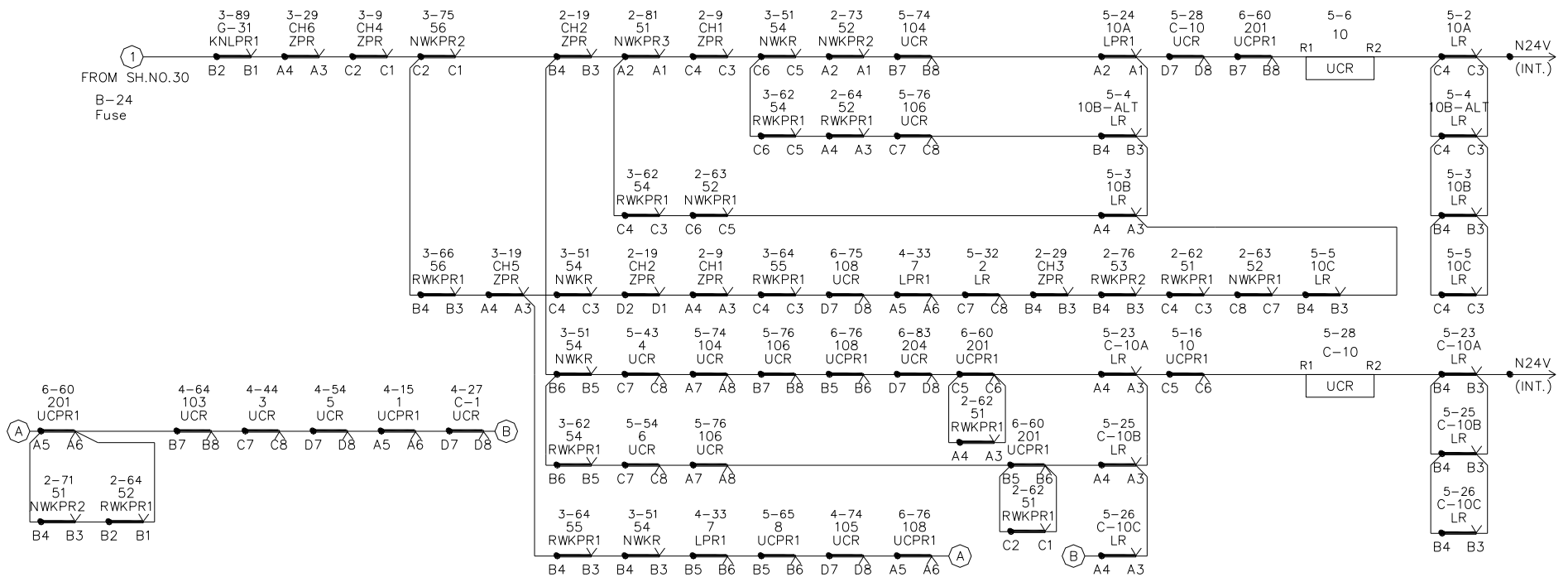

Fig – 9.4.01 - Main Signal and Calling-on Signal UCR Circuits

9.5 Route Locking Circuits

- 1 One ALSR is provided for each signal normally. A common ALSR can also be provided for 2 or 3 conflicting signals.
- 2 ALSR is normally energized relay indicating that the route is not locked.
- 3 As soon as UCR picks up checking the correct setting of the route, ALSR drops and locks the route by de energizing the WLRs of the points in the route.
- 4 ALSR dropping, the overlap locking relay OVSR (a normally energized relay as ALSR) drops and locks the points in the overlap by de-energizing the WLRs of the overlap points.

(After the route and overlap locked, the signal control relay HR picks up ensuring all other safety conditions and the signal clears. This is explained in detail in chapter 9.6)

Route Releasing

Under normal condition, ALSR picks up again after the arrival of the train ensuring the following conditions:-

- a) The signal has been put back to danger as soon as the first pair of wheels of the train passes the signal and shunts the first track circuit dropping the track relay. Proving the back contact of the signal control relays (HR, DR and UHR) ensures that the signal has gone back to danger. (That is it is not displaying any OFF aspect)
- b) The track circuits from the foot of the signal upto the berthing track have picked up after the passage of the train over them. These track circuits are known as “Back or Route Locking” track circuits. Front contacts of all these track circuit relays are proved for this purpose. (Note : The platform / Reception Line track circuits are not back locking track circuits)
- c) ALSR picks up only by the sequential operation of the back locking track circuits which can take place only by the actual movement of the train over them and not due to any track bobbing (The sudden dropping and picking up of any track relay at random is known as track bobbing. The cause is not known) the front contact of TSSLR relay ensures this condition.

- d) UCR has dropped. This is ensured by the back contact of the UCPR relay. (When the first track circuit is occupied, the TSR relay drops which in turn de-energize the LR relay of the route set. LR dropping UCR drops.)

Track Stick Relay (TSR) refer Drg.No. 9.5-02

- 1 The TSR is controlled by the track circuit ahead of the signal.
- 2 Normally, one TSR is provided for each signal controlled by the first track circuit after the signal.
- 3 Sometimes, two or three conflicting signals have a common track circuit ahead, a common TSR is provided for these signals.
- 4 The TSR is normally energized relay under the control of the first track relay. Once it picks up it is kept energized by a stick feed through its own front contact.
- 5 Once a train passes the signal and drops the first track relay, the stick feed is cut off and TSR drops. This causes LR, UCR and signal control relays to de energize and prevents automatic re clearance of the signal.
- 6 Subsequently, when the train clears the first track, the track relay picks up. TSR picks up proving that the UCR and the signal control relays have dropped and sticks.

TSR1, TSR2, TSSLR Circuits (Refer Drg. No. 9.5-03)

Assume that the route for signal no.10 (for any route) is set and locked and the signal is cleared. 10ALSR↓, 10HPR1↑, C-10HR↓.

(TSR1, TSR2, TSSLR relays are also known as sequence proving relays and are normally de energized.)

- 1 When the train passes the signal, the signal TSR drops. 10 HPR1↓. With 10T TPR↓ 10/C-10 TSR1↑-↑
- 2 As the train moves further, 10T1 TPR↓ and 10T TPR↑ with 10/C-10 TSR1↑-↑, 10T TPR↑ 10 T TPR↓, 10/C-10 TSR2 ↑-↑

- 3 As the train moves further and occupies 56BT and clears 10T1, with 10/C-10 TSR2 \uparrow - \uparrow 10T1 TPR \uparrow 56BT TPR \downarrow 10/C-10 TSR3 \uparrow - \uparrow
- 4 10T, 10T1 and 56 BT are common for all the three routes of signal no 10. further sequence proving depends on the route set.
- 5 For 10A route the track circuits are 54T and 04T1. For 10B route, the track circuits are 54T and 06T1. For 10C route, the track circuits are 56AT, 3T, 5T and 05T
- 6 For 10A route, with 10/C-10 TSR3 \uparrow - \uparrow , 56BTTPR \uparrow , 54T TPR \downarrow , 04T1TPR \downarrow 54NWKR \uparrow 10/C-10 TSR4 \uparrow - \uparrow
- 7 For 10B route, 10C/C-10 TSR3 \uparrow - \uparrow , 56BT TPR \uparrow , 54T TPR \downarrow , 54 RWKPR1 \uparrow , 06T1 TPR \uparrow , 56 NWKPR2 \uparrow , 10C/C-10 TSR4 \uparrow - \uparrow
- 8 For 10C route, 10/C-10 TSR3 \uparrow - \uparrow , 56BTTPR \uparrow , 56RWKPR1 \uparrow , 56AT TPR \downarrow 10/C-10 TSR4 \uparrow - \uparrow
- 9 For 10C route, as the train moves further with 10/C-10 TSR4 \uparrow - \uparrow , 56AT TPR \uparrow , 3T TPR, 10/c-10 TSR5 \uparrow - \uparrow
- 10 For 10A And 10B Routes also, with 10/C-10 TSR4 \uparrow - \uparrow , 56 NWKR2 \uparrow , 10/C-10 TSR5 \uparrow - \uparrow
- 11 For the 10C route as the train moves further, with 10/C-10 TSR5 \uparrow - \uparrow , 3T TPR \uparrow , 5T TPR \downarrow , 05T TPR \downarrow , 10C/C-10 TSSLR \uparrow - \uparrow
- 12 For 10A and 10B routes, through 10/C-10 TSR5 \uparrow , 56NWKPR2 \uparrow , 10/C-10 TSSLR \uparrow - \uparrow
- 13 Thus whichever route of signal no.10 is set proving the sequential operation of the back locking track circuits, the final relay 10/C-C10 TSSLR \uparrow - \uparrow .
- 14 With TSSLR \uparrow , proving the train has cleared the last back locking track circuit (i.e., the train has completely arrived on the berthing track) the 10ALSR picks up and sticks thus releasing the route.
- 15 Energisation of 10 ALSR (refer Drg. No.9.5-01)
For 10A and 10B routes : B24, 10UCPR1 \downarrow 10HPR1 \downarrow 10DR \downarrow 10BUHR \downarrow ,
10CUHR \downarrow , 10/C-10TSR \uparrow , 10TTPR \uparrow , 10T1TPR \uparrow , 56BTTPR \uparrow , 54T TPR \uparrow ,
56NWKPR2 \uparrow , 10/C-10 TSSLR \uparrow , 10ALSR N24, 10ALSR \uparrow - \uparrow

For 10C route: B24, 10UCPR1↓, 10HPR1↓, 10DR↓, 10BUHR↓, 10CUHR↓,
 10/C-10TSR↑, 10TTPR↑, 10T1TPR↑, 56BTTPR↑, 56RWKPR↑, 56ATTPPR1↑,
 3T TPR1↑, 5T TPR↑, 10/C-10TSSLR↑, 10ALSR N24, 10 ALSR↑-↑.

Emergency Route Release

After the signal is cleared it is required to cancel the route. When the train is approaching the signal, emergency route release is done. This is done in two stages. In the first stage, the signal is cancelled by pressing GN and EGGN. This operation throws the signal to danger immediately. In the second stage the route release is initiated by pressing GN and EUYN. But the route release can take place only after a time delays of 2 minutes to ensure that the train has come to a stop at the foot of the signal. But, if the train has passed the signal before 2 minutes time delay and occupied the track circuits ahead, the back locking on the route will be effective and the route cannot be released unless the train clears all the back locking track circuits and arrives fully on the berthing track. In this case the route is released automatically.

When GN and EUYN are pressed EUYR↑-↑, through GNR↑ EUYNR↑. The circuit is as follows: (Refer Drg.No.9.5-01) B24, 10UCPR1↓, 10HPR1↓,..... 3TTPR1↑ 5TTPR↑ B4 terminal of 10/C-10 TSSLR to B2 terminal of 10RECR C8 terminal of C-10ALSPR1↑, 10ALSR↓, 10/C-10TSSLR↓, 10/C-10RRBUR↓, RRBUNR↓, EUYNR↑, 10GNPR1↑, 10/C-10EUYR N24, 10/C-10EUYR↑-↑.

Energisation of EUYR switches on the timer circuit for 2 minutes time delay. Refer Drg No.9.5-03. The timer used here is an electronic timer. Three Q series neutral relays JS1, JS2 and JN are associated with the timer circuit. These relays are normally de energized. As electronic timers are susceptible for failure on the unsafe side, two such timers are used to perform in parallel. The output from the two timers independently operates the JS1 and JS2 relay. Only when both JS1 and JS2 are energized JN relay can pick up and release the route. The circuit is as follows:

B24..... 10ALSR↓ A6 terminal of 10ALSR to A6 terminal of C-10ALSR to A5 terminal of 10/C-10EUYR to B2 terminal of 10/C-10 EUYR EUYR↑ RRBUR↓ to B1 terminal of RRBUR JN↓ to IN terminal of the first timer and to the IN terminal of the 2nd timer. Both the timers operate simultaneously and after two minutes time delay energize JS1 and JS2 relays. Now, the b24 supply from D5 terminal of JN to A2 terminal of Js1 JS1↑ JS2↑ Jn N24. Picking up of JN indicates 2 minutes time delay is over. JN relay sticks through its front contact by passing JS1↑ JS2↑. Back contact of JN (D5-D6) breaks and cuts the feed to the timers. The two timers, JS1 and JS2 are restored to their normal position.

Now the route is released by energizing 10ALSR relay. Refer again Drg.No.9.5-01. B24 supply at B2 terminal of 10 RECR, RECR↑ C-10HECR↓ EUYR↑, RRBUR↓ B3 terminal of RRBUR Jn↑ B3 terminal of TSSLR ALSR relay N24. ALSR10↑-↑ 10ALSR picking up, WLRs of the points in the route energise and the points become free for operation. Also, 10ALSR picking up cuts of the feed to the JN relay (Drg No.9.5-03) and the JN relay drops and returns to its normal position. EUYR relay also drops.

Thus the route is released after 2 minutes time delay ensuring that the train has come to a stop at the foot of the signal. If however, the train could not stop at the signal and passes and occupies the back locking track circuits, the track stick relay (TSR) drops and cuts off the B24 supply to B4 terminal of 10/C-10 TSSLR. Therefore ALSR cannot energize. As B24 supply is not available at B4 terminal of 10/C-10 TSSLR, there is no supply to EUYR relay. EUYR drops cutting off the feed to the timers (DRG.NO.3) and the timers are restored to their normal position. The train has to be received on the route which is already set. After the train arrives on the berthing track ALSR picks up through TSSLR↑ and the route is released.

Super Emergency Cancellation of Route

After the reception of the train on the berthing track, if any of the back locking track circuits fail and the track relay does not pick up, the ALSR relay cannot energize and the route cannot be released. The points remain locked in the route and other routes over the points cannot be set. The route can be released only after the track circuit

failure is rectified and the ALSR is energized. This may take considerable time and the train traffic will be held up. To avoid delay to the traffic a provision has been made on the panel to release the route even under the back locking track circuit failure condition. This is an unsafe provision in the sense that the SM may release the route even when the train is actually moving over the back locking track circuits. Once the route is released the points become free and can be operated under the wheels which may cause derailment.

In order to minimize the unsafe feature in this provision, co operative feature has been introduced in this super emergency route release. Both the SM and the signal staff have to first verify there is no vehicle on the track circuits before releasing the route. For this purpose a lock is provided on the panel and the key will be in the custody of the signal staff. After verification of the track, the signal man has to insert his key in the lock and turn it. If now the SM presses the signal button and RRBUN, the route will be released after a time delay of 2 minutes. The key with the signal man is called RRBUN KEY.

With RRBUN Key reversed RRBUN SNR picks up with RRBUNSNR \uparrow and RRBUN pressed RRBUNR picks up (Note: SM has to press both GN and RRBUN).

RRBUR circuit

B24, 10UCPR1 \downarrow , 10HPR1 \downarrow , 10DR \downarrow , 10BUHR \downarrow , 10C UHR \downarrow to A2 terminal of 10 ALSR to B5 terminal of 10ALSR 10ALSR \downarrow , 10UCPR1 \downarrow , C-10UCPR1 \downarrow , 10/C-10EUYR \downarrow , 10GNPR1 \uparrow , RRBUNR \uparrow , RRBUR N24, RRBUR \uparrow - \uparrow . RRBUR once energized switches on the timer. Refer Drg.No.9.5-03.

B24 10ALSR \downarrow to A6 terminal of C-10 ALSR to A5 terminal of EUYR EUYR \downarrow , RRBUR \uparrow , JN \downarrow to timers. After a time delay 2 minutes, JN \uparrow - \uparrow , B24 at terminal D2 of TSR to terminal A7 of EUYR EUYR \downarrow , RRBUR \uparrow , JN \uparrow 10ALSR N24 10ALSR \uparrow - \uparrow . The route is released. The emergency route release and super emergency route release are recorded in their respective counters. Refer Drg.No.9.5-02.

Overlap Locking And Release

For locking the overlap points OVSR relay is provided. This is also a normally energized relay like ALSR. When ALSR drops, OVSR also drops and locks the overlap points. This relay can be provided individually for the overlaps. Where 2 or 3 overlaps conflict with one another, a combined OVSR can be provided as only one overlap can be set at a time.

Once a route is set and locked and UCR picks up ALSR and OVSR de energize. The signal is cleared. After the arrival of the train, the route behind the train is released automatically. But the overlap can be released only after a time delay of 2 minutes. This time delay is given to ensure that the train has come to a stop at the foot of the starter signal. In case the train runs through the main line or loop lines and clears the overlap points and the track circuits within 2 minutes time delay, the OVSR can pick up before the lapse of 2 minutes and release the overlap points. The timer also will be switched off.

Refer Drg.No.9.5-04

Case 1: Assume route 10A is set and signal no10 is cleared. The overlap locking relay 4/6B/8 OVSR has dropped locking the overlap. When the train arrives on the berthing track O4T and O4T1, the 10A route is released automatically as we have already seen. 10ALSR has picked up. Under this condition, for releasing the overlap the timer is switched on. The circuit is as follows:

B24 10UCPR2↓, 10ALSPR2↑, EOVNXR↓, B2 terminal of JN to C5 terminal OVSR OVSR↓ O4T1TPR↓ or O4T TPR↓ EOVNXR↓ JN↓ to timers. After 2 minutes JS1 and JS2 pick up. Now the supply from A5 terminal of Jn to A2 terminal of JS1, JS1↑, JS2↑ JNNX24. JN relay picks up and sticks. Now the B24 supply at terminal B2 of Jn through JN front contact to OVSR relay and OVSR picks up and sticks. OVSR picking up WLRs of overlap points are energized and the overlap is released. The back contact C5-C6 of OVSR breaks and cuts off the supply to the timers. The timers JS1, JS2 and JN relays are restored to their normal position.

Case 2: With 10 A route set and home signal cleared, when the train is approaching the home signal, the signal is put back and emergency cancellation of the route is done by pressing GN and EUYN. The route is released after two minutes time delays as we have already seen. 10ALSR relay has picked up. Now for releasing the overlap the 4/6B/8 OVSR picks up as follows:

B24 10UCPR2↓, 10ALSPR2↑, EOVNXR↓, O4T1TPR↑, O4TTTPR↑, 52NWKPR3↑, 4TTTPR1↑, O2 TPR↑ to B1 terminal of JN to OVSR N24. OVSR picks up and release the overlap. There is no time delay in this case as the train has stopped at the home signal itself.

Case 3: In the case of run through over the main line, when the train is passing over O4T1 and O4T the route behind the train is released by energization of 10ALSR. Through 10ALSR2↑, EOVNXR↓, 4/6B/8 OVSR↓(C5-C6) O4 T1TPR↓ or O4T TPR↓ the timer is switched on. In the mean time if the train clears the berthing tracks and the overlap tracks 4T and O2T, OVSR is energized through the front contacts of these track relays and the overlap is released. The back contact (C5-C6) of OVSR breaks and cuts off the feed to the timers. The timers are restored to their normal position.

Case 4 : Emergency Overlap Release

After the reception of the train on the berthing track of the route is not released due to any failure (10ALSR not picking up) the front contact (C4-C3) of 10 ALSPR2 will not be available in the OVSR circuit and OVSR cannot energize and the overlap cannot be released, or the route is released (10ALSR↑ 10ALSPR2↑) but the overlap is not released due to failure of the overlap track circuits 4T or O2T after the passage of the train in the case of a run through movement. Emergency overlap release is done by pressing the starter signal button (4GN) and the emergency overlap release button (EOVN) 4GNR and EOVNR relays pick up by this operation of buttons. EOVNXR is now energized as follows”

B24 10UCPR2↓ to C4 terminal of 10 ALSPR2 to D2 terminal of EOVNXR to B5 terminal of 4/6B/8 OVSR OVSR↓ C2 terminal of EOVNXR B4 terminal of 4 GNR↑ EOVNR↑ EOVNXR N24, EOVNXR picks up and sticks.

Now, the B24 supply at terminal C2 of EOVNXR EOVNXR↑ to terminal A6 of EOVNXR JN↓ to the timers. After 120 seconds through JS1↑ JS2↑ Jn picks up and sticks. The OVSR relay picks up as follows:

B24 10UCPR2↓ EOVNXR↑(D2-D1) JN↑(D2-D1) JN↑ (B2-B1) OVSR N24 OVSR picks up and sticks.

Thus in the case of emergency overlap release. The overlap is released after a time delay of 120 seconds.

Once OVSR picks up EOVNXR↓ and also the feed to the timer relays is cut off as OVSR back contact (B5-B6) breaks and the timers, JS1, JS2 and JN are restored to their normal position.

For 10B route with overlap set on the sand hump, the concerned OVSR relay 6A OVSR and not 4/6B/8 OVSR. In this case 4/6B/8 OVSR should not be allowed to drop when 10UCPR2 picks up. When 10B route is set with overlap on the sand hump, if this drops it will unnecessarily lock the overlap points 51 and 53 which will affect parallel movements over these points. Therefore 4/6B/8 OVSR maintains its stick feed through the front contacts of 56NWKPR3, 54 RWKPR2 and 52NWKPR3 by passing 10UCPR2 back contact (A7-A8)

If 10B route is set with overlap set on the main line with 52 reversed, 4/6B/8 OVSR drops for locking the overlap. In this case if the train is stopped at the home signal due to emergency cancellation of the signal or if the train has run through the OVSR relay picks up through O6T1 TPR↑, O6T TPR↑, 6T TPR↑, 52RWKPR2↑, 4T TPR↑ and O2T TPR↑ and the overlap is released.

Similarly for 10C route, the OVSR picks up through C5T TPR↑, 08T TPR↑, 53RWKPR3↑, 51/53TPPR1↑, 51RWKPR2↑, 4T TPR↑, C2T TP↑ and the overlap is released.

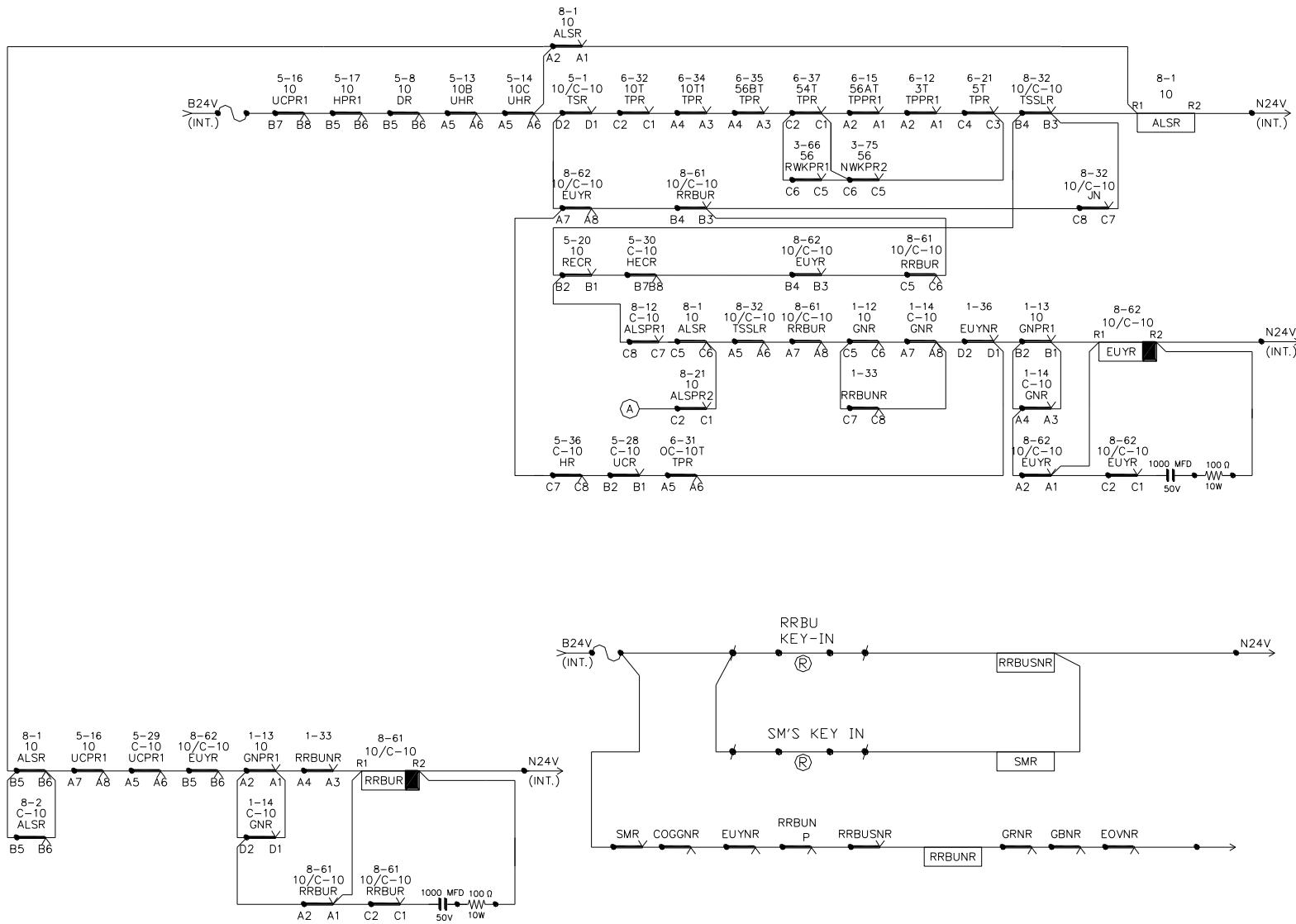

Fig – 9.5.01 – Route Locking and Release Circuits

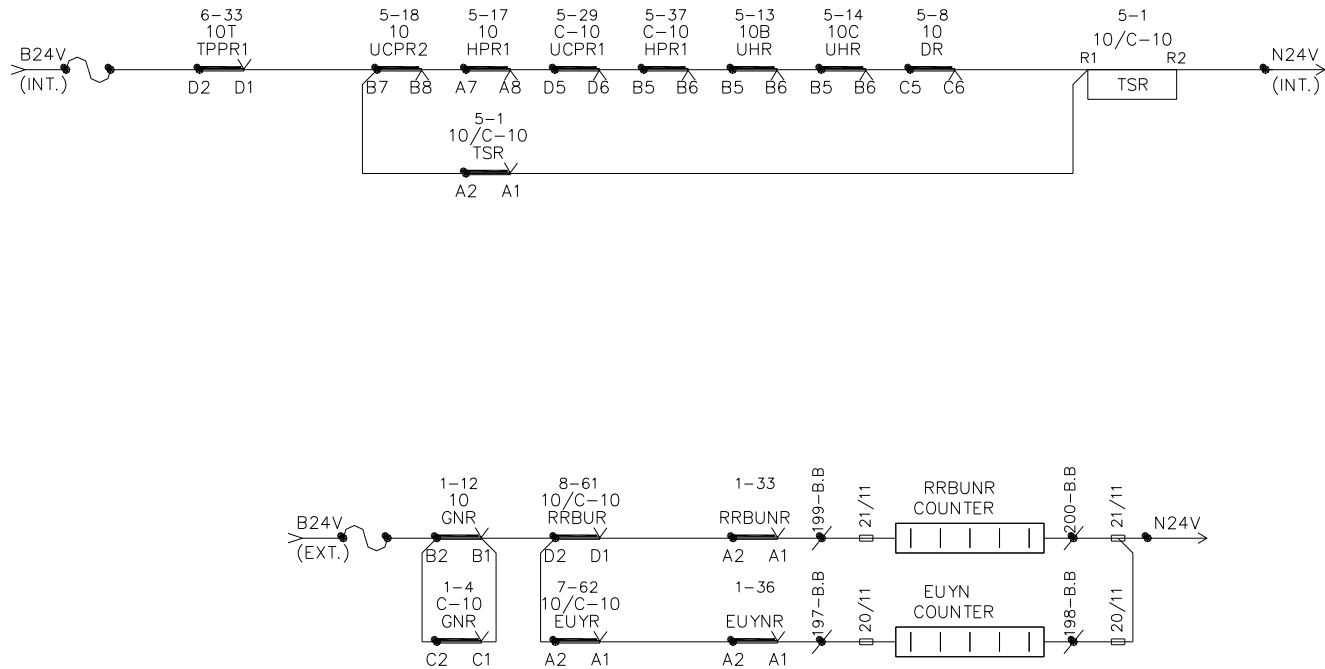

Fig – 9.5.02 – TSR and Emergency Route Release Counters Circuits

9.6 Signal Control

HR Circuit

After the route is set, checked and locked the signal has to be cleared. To control the yellow aspect of the signal a HR relay is provided. The green aspect is controlled by DR relay. There is no control relay for the normal red aspect of the signal. The signal displays Red aspect if HR and DR are not energized. Thus for a 3 aspect signal there are 2 controlling relays. Similarly for a 4 aspect signal there are 3 controlling relays- HR, HHR and DR. The HHR controls the double yellow aspect.

The following conditions have to be fulfilled before we energize HR relay and the signal displays the off aspect:

- 1 The route is clear of any obstruction. For this the track relays of all the track circuits right from the foot of the signal up to the starter signal ahead in the route and the overlap track circuit relays are in their energized position. (TPR↑/TPR1↑)
- 2 The points in the route and overlap have been correctly set in the required position (NWKR↑ / RWKR↑)
- 3 The points have been locked (WLRs↓)
- 4 The route has been checked for correct setting (UCR↑)
- 5 The route locking relay ALSR is de energized (ALSR↓)
- 6 The overlap locking relay OVSR is de energized (OVSR↓)
- 7 The sequence proving relays of the track circuits in the route have returned to their normal position after the previous operation (TSR1↓, TSR2↓, TSR3↓, TSR4↓, TSR5↓, TSSLR↓)
- 8 Emergency route release relays EUYR and RRBUR have come back to their normal position after the previous operation (EUYR↓, RRBUR↓)
- 9 The relays associated with the timers have come back to their normal position (JS1↓, JS2↓, JN↓)
- 10 Level crossing gate, if any in the signal route is locked against the road traffic. (G-31 KNLR↑)
- 11 The signal ahead that is the starter and is at ON (4RECPR1↑)
- 12 Directly conflicting signals are not cleared (C-10 HPR1↓, 201 HPR1↓)

- 13 For the main line the route lamp controlling relays are de energized (10B UHR↓, 10 C UHR↓) and the route lamps are not burning (UECR↓)
- 14 Means to put back the signal to danger as soon as the train passes the signal is provided (10/C-10 TSR↑)
- 15 The circuit is designed on the principle of double cutting so that a single positive false feed appearing on the R1 terminal of the HR relay due to any short circuit between the circuits will not pick up HR relay so long as UCR or TSR is de energized and ALSR is energized (Unsafe conditions to pickup HR) as the negative of the circuit N24 is cut off from R2 terminal of the HR relay.
- 16 The relay is cross protected by connecting 10 ALSPR2 front contact across the relay. In case of a double fault that is a positive false feed on R1 terminal and a negative appearing on R2 terminal so long as the ALSR is energized the cross-feed gets short circuited through the 10 ALPSR2 front contact and the HR Relay will not energize.

Note : Even though a double fault is a remote possibility, HR being a vital relay (if it picks up signal will display off aspect) Cross protection is provided by a simple arrangement of connecting the ALSR front contact across the relay.

If the route is set for the loop line 10B, 10BUHR has to pick up first and light up the route lamps. Proving that the route lamps are burning (UECR↑); the HR relay picks up and the home signal displays the yellow aspect so that yellow with route lamps is displayed for reception on the loop line.

Similarly for 10C route, 10CUHR picks up and lights up the concerned route lamps. As before proving UECR has picked up, HR picks up and the home signal displays yellow aspect.

Proving all the safety conditions enumerated the 10 HR relay picks up and the home signal is cleared to yellow aspect for the main line.

For a run through movement over the main line, starter signal no 4 is cleared and displays green aspect and 4 DECPR1 is energized and 4 RECPR1 drops. The feed to HR relay is maintained through 4DECPR1 front contact.

When starter signal no 4 is displaying green, 10 DR relay also picks up as shown below

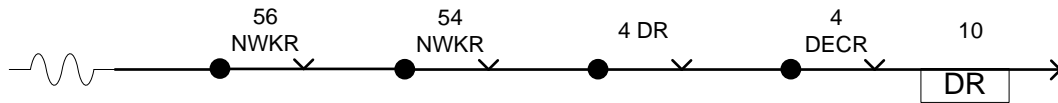

With 10HR and 10DR energized the home signal displays green aspects

For 10B route, point no 54 is reversed. Proving all the safety conditions upto 54 NWKR1 (D2 –D1) the circuit now progresses through 54RWkPR2↑ 06T1TPR↑

06TTPR↑6TTPPR1↑ 52NWKPR4↑ 6A OVSR↓ 6RECP1↑ for the overlap set on the sand hump and through 52RWKPR2 (B4-B3)↑..... 4/6B/8 OVSR 6RECP1↑or 6HECR↑ (for run through over the loop line) if the overlap is set on the main line) 10C UHR↓ 10 UCR↑ 10B UHR 10UCR↑ 10/C-10TSR↑ 10 ALSR↓ to N24

10B UHR picking up the route lamps are lit on the home signal and UECR↑. Now the feed available at A8 terminal of 10 CUHR through 10 BUHR↑ 10UECP1↑ 10 UCR↑ 10 HR 10UCR↑ 10/C-10 TSR↑ 10ALSR↓ N24

10 HR also picks up and the home signal displays yellow with route for the loop line.

Similarly for 10C route for reception on the common loop 10C UHR picks up through 56 RWKPR2↑ and all the other conditions. 10C UHR lights up the other set of route lamps for 10 C route and proving that the route lamps are burning (10UECP1↑) HR relay picks up and the signal displays yellow with route for reception on the common loop.

Calling On Signal C–10 Working

- Signal explained - C-10 for route leading to DN. mainline
- C-10 GN +D-4 UN BUTTONS Pressed.
- C-10 GNR and its repeater operate along with D4-UNR with its repeaters.
- Overlap is not required for calling on signal, as train is brought to a stop before Calling on is cleared.

- However, shunting or any main signal movement that may come in the path in the calling on signal in the portion beyond the starter where train is received on calling on signal will stop will have to be prevented.
- No run through of the train received on calling-on signal is permissible. So starter ahead of calling-on is not to be cleared with CALLING-ON.
- After C-10GN and D-4-UN button relays operate the route selection relay C-10A LR picks up proving conflicting routes LRs and ALSRs are de-energized including the main signal located above the calling-on signal.
- C-10A LR drives only the points in the route, as overlap points are not required.
- 56 and 54 points are taken to N and their NWKRs are energized.
- C-10 UCR picks up proving the above route set within 56 & 54 normal.(refer fig 9.4.01)
- C-10 ALSR drops due to C-10 UCR picking up (fig 9.6.03)
- The common timers 10/C-10 JS1, JS2 and JN will operate to provide a time delay of 2 minutes after C-10 ALSR drops and approach track OC-10T is occupied. This is to indirectly prove the stopping of the train at the foot of calling-on signal by ensuring that C-10 HR picks after 10/C-10 JN operates after the time delay. Please refer to Timer circuit available in the chapter route locking.
- The time delay circuit is started by 10/C-10 EUYR (fig 9.5.01).This EUYR has three parallel paths to pick up

The first path is for emergency route cancellation for main signal 10 through its ALSR back contact. The second is for release of the route of calling on signal C-10 under emergency through its ALSR back contact.

The third path is through C-10 HR back contact, OC-10T TPR back contact. This third path proves calling on route has been checked, train has come to the foot of the signal as the approach track is occupied and calling on HR is yet to be picked up.

- After the time delay is initiated by picking up of 10/C-10EUYR, the time delay relay JN will pickup after 120 seconds.
- HR circuit (Fig 5.can be traced. This proves all the conditions required for the, main signal except the overlap requirements .In this circuit the front contact of 10/.C-10 JN is used to complete the C-10 HR pick-up.

- However, once HR picks up the time delay relays will be cut-off as their initiation is through C-10HR back contact. However, C-10 HR contact by passes the front contact of timer relay to hold the circuit of HR.
- HR picking up will light the calling on signal lamp and its HECR will pick up

NOTE: Since calling on signal is a slow speed movement, no route indication is provided for loop lines. That is why there is no UHR for calling on signal.

Releasing route on Calling-on signal.

If you see the HR Circuit of calling on only the first track is proved for clearance, as calling on is for receiving a train on an occupied berthing track or any of the track circuit failing.

TSR, TSR1, TSR2 etc are common for main signal 10 and C-10. If all the track circuit are functioning normally, calling-on route will be released automatically. If not route is to be released by emergency route cancellation like the main signal except instead of main signal GN, Calling-on GN is to be pressed.

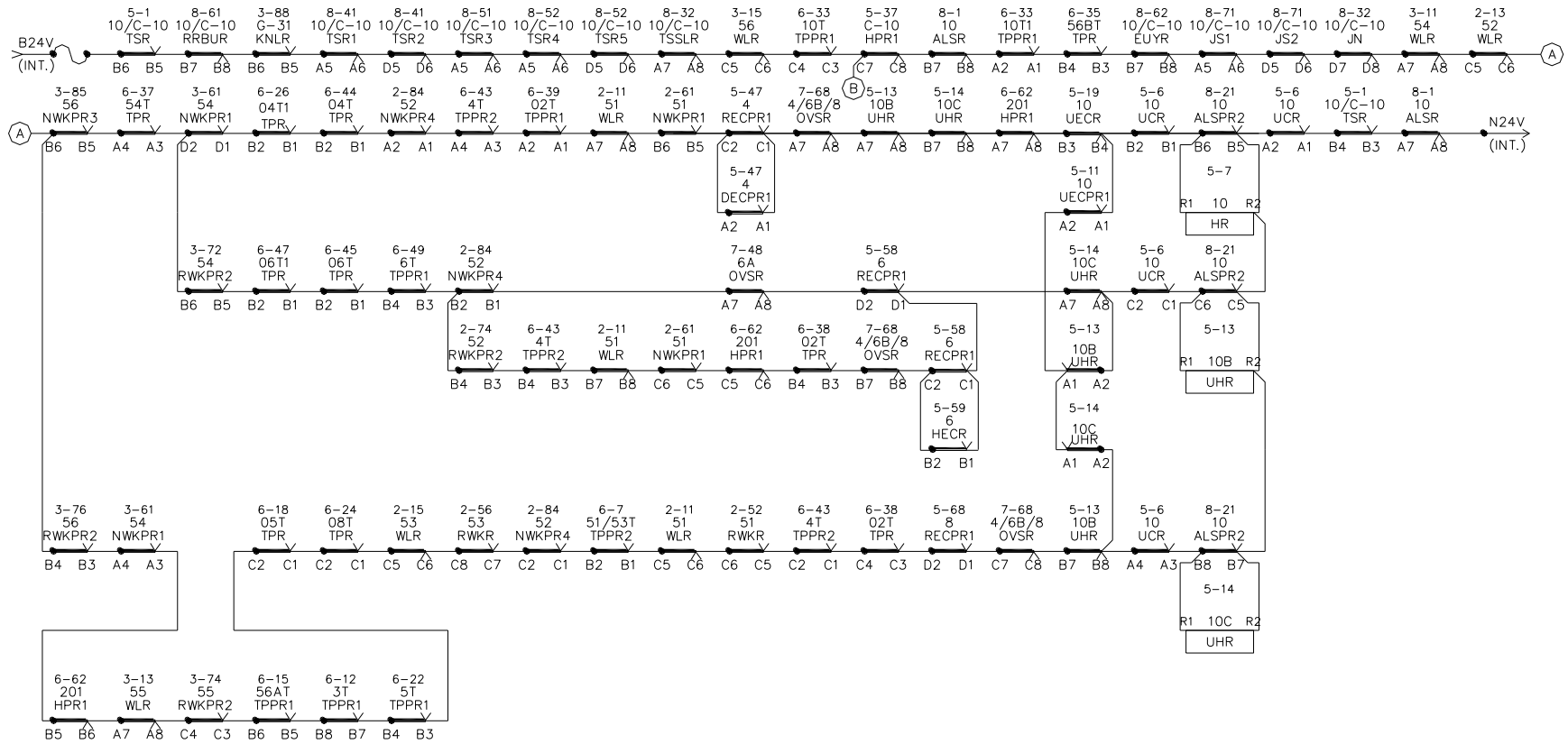

Fig – 9.6-01 – HR & UHR Circuits

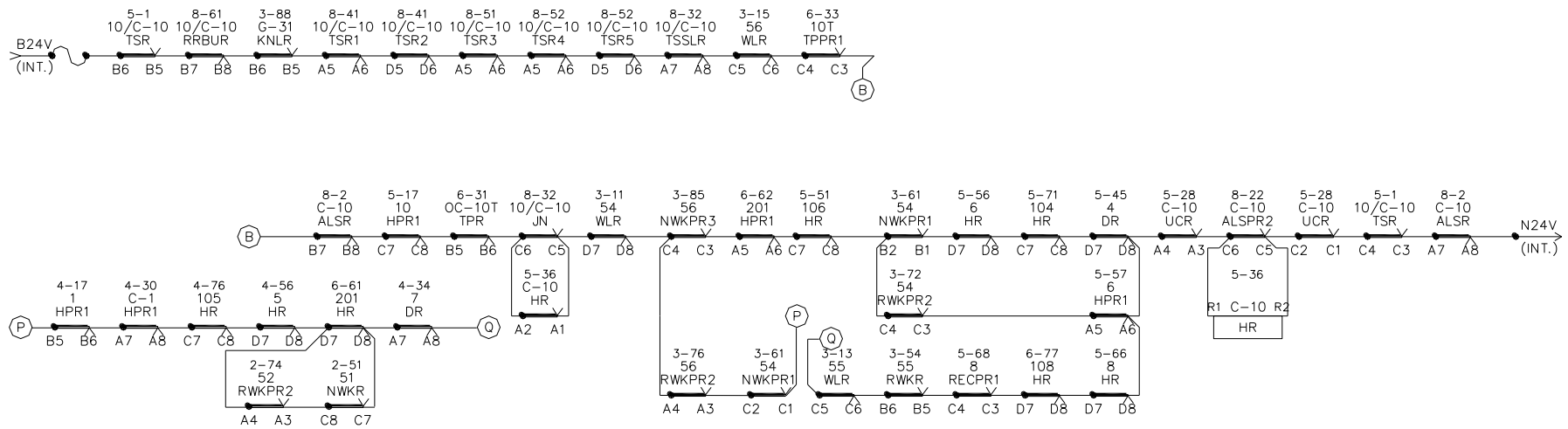

Fig – 9.6-02 – HR Circuits of C-10

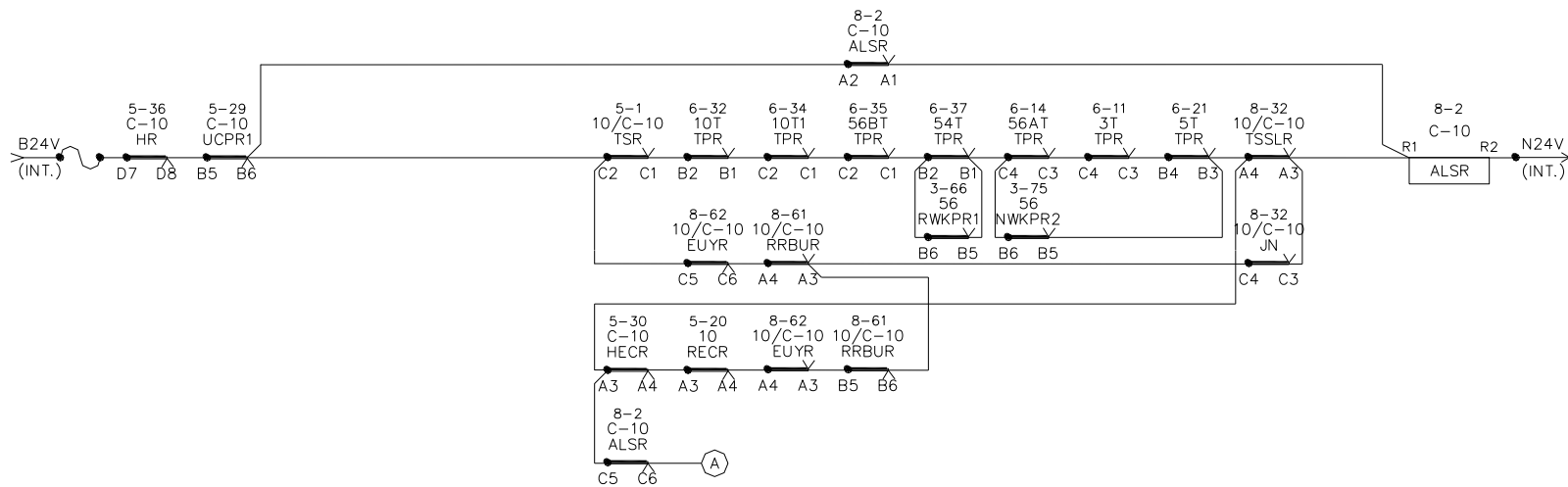

Fig – 9.6-03 – ALSR Circuits of C-10

9.7 Route release (Automatic, Emergency, and overlap release)

We have seen in the earlier chapters how the route is set, checked, locked and the signal control relay HRs picks up and clears the signal. Now we will see how the route is released. after the reception of the train

1. Automatic route release:

When the train passes the signal and operates the back locking track circuits sequentially the TSR1, TSR2.....TSR5 and TSSLR relays operate, picks up the ALSR Relay and releases the route. In this case, the route is released automatically.

2. Emergency route release

After the signal is cleared and before the train approaches the signal, the signal can be put back to danger and the route can be released by an emergency operation. This emergency route release can be done only if there is no track circuit failure.

3. Super emergency route release

After reception of the train on the berthing track. If the route is not released due to any track circuit failure, the super emergency route release is done.

4. Overlap release

The overlap releases automatically 2 minutes after the arrival of the train on the berthing track. If the overlap is not released due to any failure, the same can be released through an emergency operation

NOTE:

The automatic and emergency route releases and the emergency overlap release have already been dealt with in greater details and with necessary circuits in chapter No 9.5.

9.8 Indications on the panel, Failure alarms and emergency counters

Various indications of the field functions such as points, signals and track circuits under different conditions are given on the control panel. Flashing indications are given to draw the attention under abnormal or failure conditions of any of the field functions.

Signal indications:

Aspects that are exhibited at each signal are indicated in their respective positions. A flashing indication is given under lamp failure.

Panel indication for signal No.10 is shown in the Drg. No. 9.8-01

Green aspect of 10 signal is indicated as 10 DGKE through the front contacts of 10DECPR. If the lamp is fused. 10 DECPR drops & flashing indication of green is given through 10DR front contact & 10DECPR back contact. Similar indications for yellow & red aspects and route indicators of signal No 10 signal, C-10 are also given.

Signal locked indication is given (10/C-10 GLKE) when a route is set & locked. When the route is cancelled manually, a flashing indication is given during the time of cancellation (Drg. 9.8-01). A steady locked indication is given through cancellation relay normal contact (EUYR & RRBUR in down condition) & through ALSR back contact. Flashing indication is given when any one of the route cancellation relay is energized.

Track indications:

Track strip indications are lit by a white light when a route is set & locked, through the back contact of ALSR. Depending upon the point position, corresponding indication strips are lit.

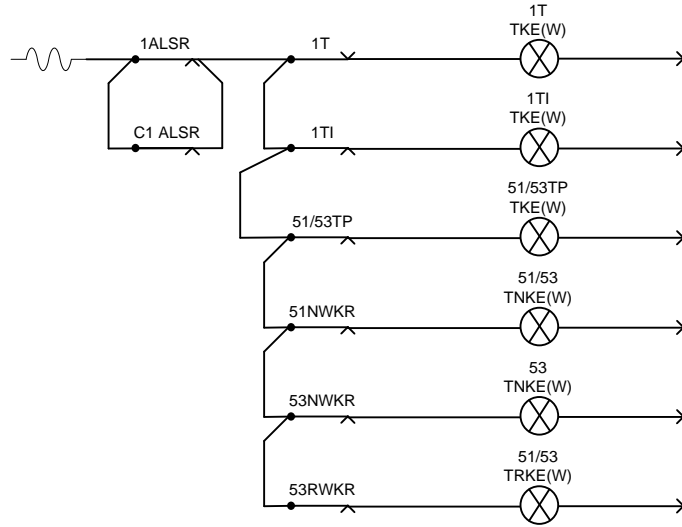

When route for sig. 1 is set, through 1ALSR back contact & the concerned track repeating relay energized contact & the point indication relay contacts, the respective indications are given.

However, when a track relay drops either by occupation of track (or) due to a failure, indication will be displayed as shown below

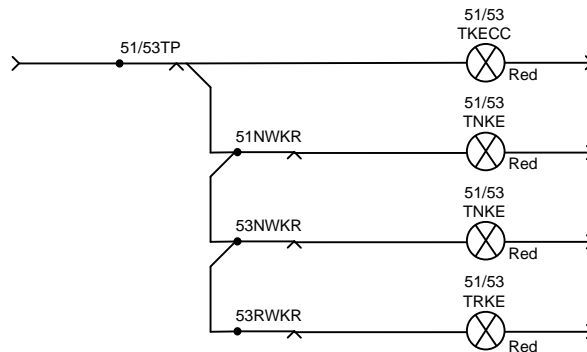

Point indication:

Point indications are given by means of two white lights one each at the main ends of cross over when normal & two white lights on the cross over when set for reverse

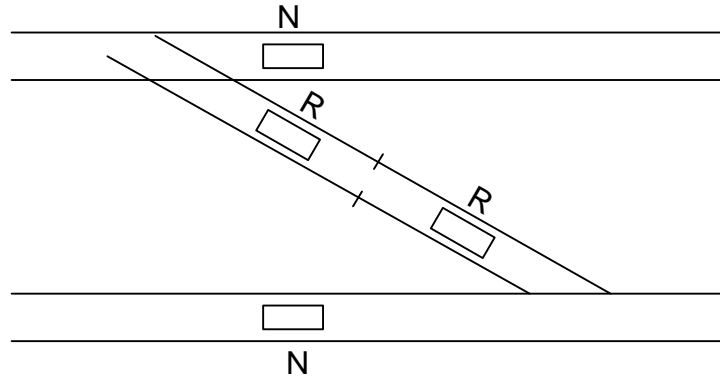

When none of the point detections is available either during operation or under failure condition, these indications are made to flash through NWKR & RWKR down contacts. Point indication circuit for point No.56 is shown in fig comprehensive list of indications that are displayed on the panel is given in chapter 7.

Failure Indications

We have seen in chapter 9.1 that the various button relays are grouped function wise and a common button normal checking relay for each group as GNCR, UNCR and WNCRT provided. When any button fails or button relay fails the button normal checking relay of that group drops and gives indication of the panel. Similarly for giving indication and alarm for the failure of the common buttons or their relays, a relay called GRXR is energized through the back contacts of these Common button relays.

Failure alarms.

- Signal and point failure alarms.(refer Drg No 9.8-03)

If any lamp of the signal, whether main signal, shunt signal or calling on signal fails a bell warning is given in the panel top to attract the attention of the panel operator to the failure in addition to giving a flashing visual indication on the signal in the panel. The bell warning is suppressed by the panel operator by pressing an acknowledgement button. For the purpose of giving audible warning signal a relay called GXR; which is slow to release relay is kept normally energized when the lamps of the signal in the yard are in tact. When any signal lamp fails, GXR drops and through its back contact bell warning is

given. Similarly if any point in the yard is not correctly set in the required position due to any obstruction.(NWKR and RWKR both de-energized) the same bell warning is given in addition to the flashing failure indication on the points configuration on the panel. For this purpose, WXR relay is provided and made slow to release so that in the course of normal working of the points when both NWKR and RWKR are de-energized till the points are set, WXR relay does not drop and give a false alarm.

In order to suppress the alarm, the panel operation presses the G/W acknowledgement button on the panel when the (G/W)XPR relay picks-up and sticks. A back contact of XPR relay in the bell circuit cuts off the supply to the bell and the bell stops, however the flashing failure indications on the panel persist till the failure is rectified. The XPR relay is de-energized and restored only when the signal or point failure is rectified.

Button failure alarm (Refer Fig 9.8.03)

A common bell relay called (G/U/WG(N))XR is energised through the front contacts of GNCR,UNCR,WNCR and GRXR. When any of these button normal checking relays drops due to button failure, the (G/U/W/G(N))XR relay drops and rings the button failure bell. The panel operator presses the same G/W acknowledgement button when the (G/U/W/G(N))XPR relay picks up and stops the bell. But the steady failure indication on the panel continues till the button failure is rectified. The XPR relay is restored to its normal de-energized position when (G/U/W/G(N))XR relay picks up after the rectification of the failure.

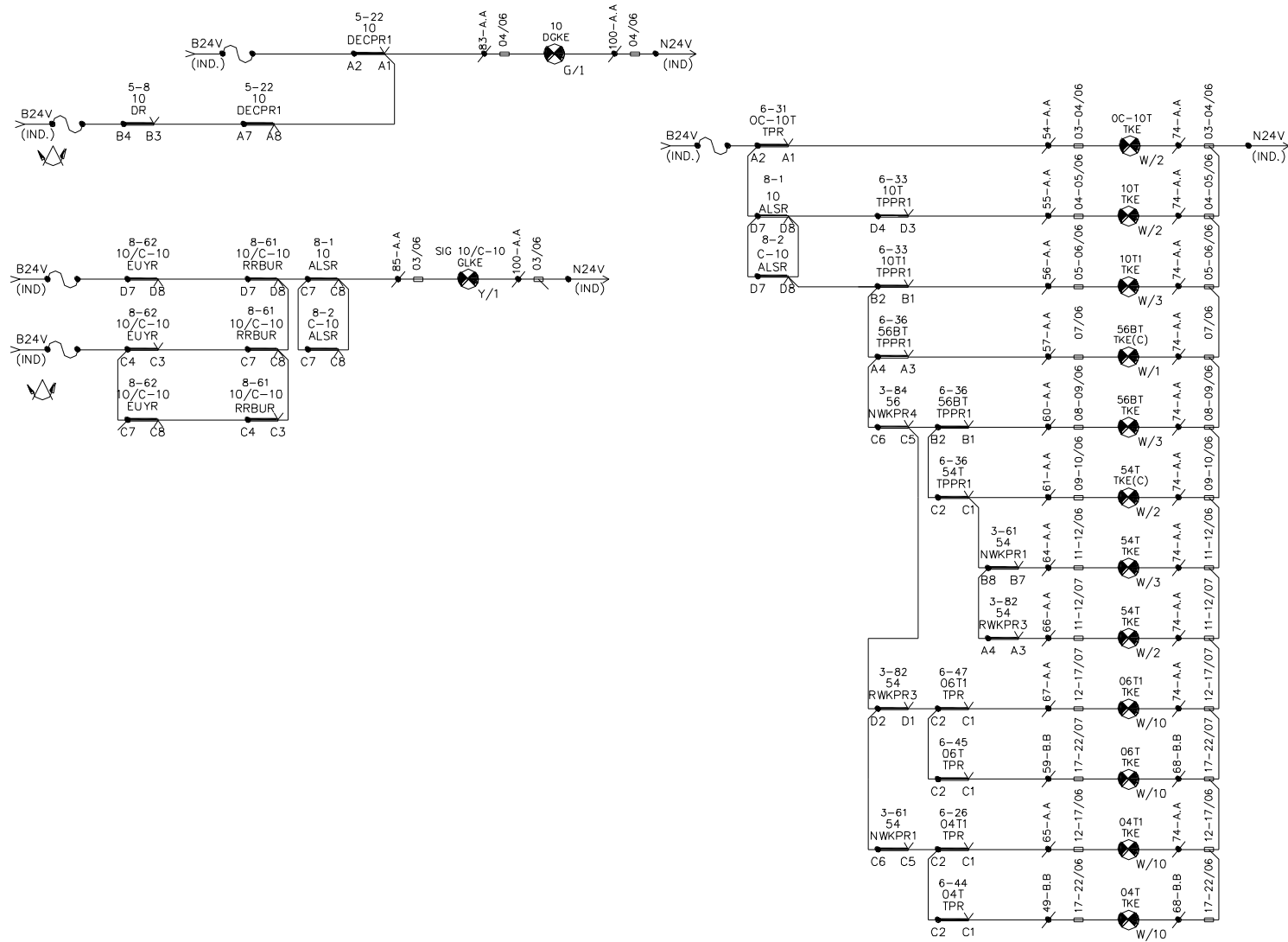

Fig : 9.8-01 – Signal & Track indications

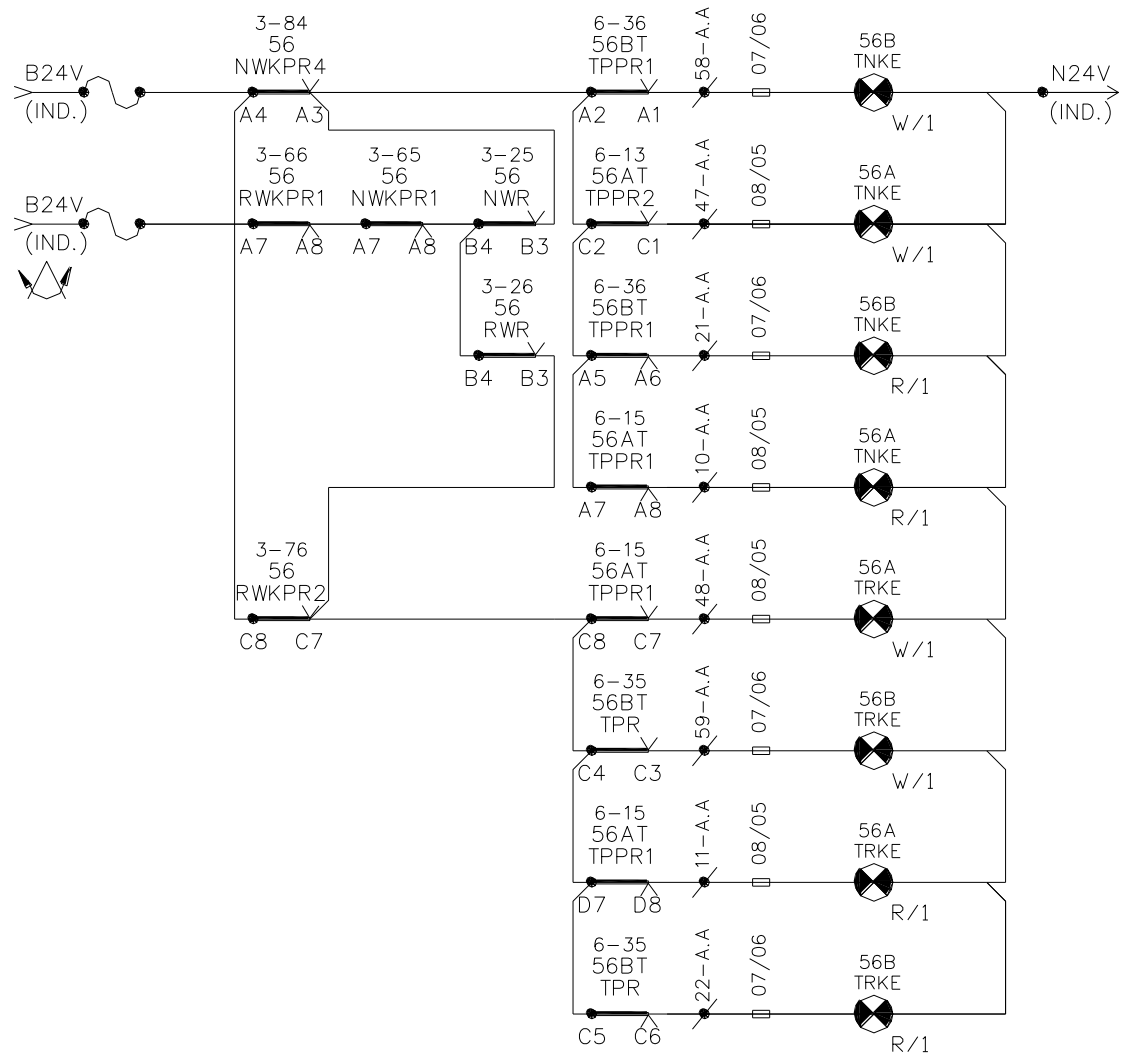

Fig : 9.8-02 – Point Indications

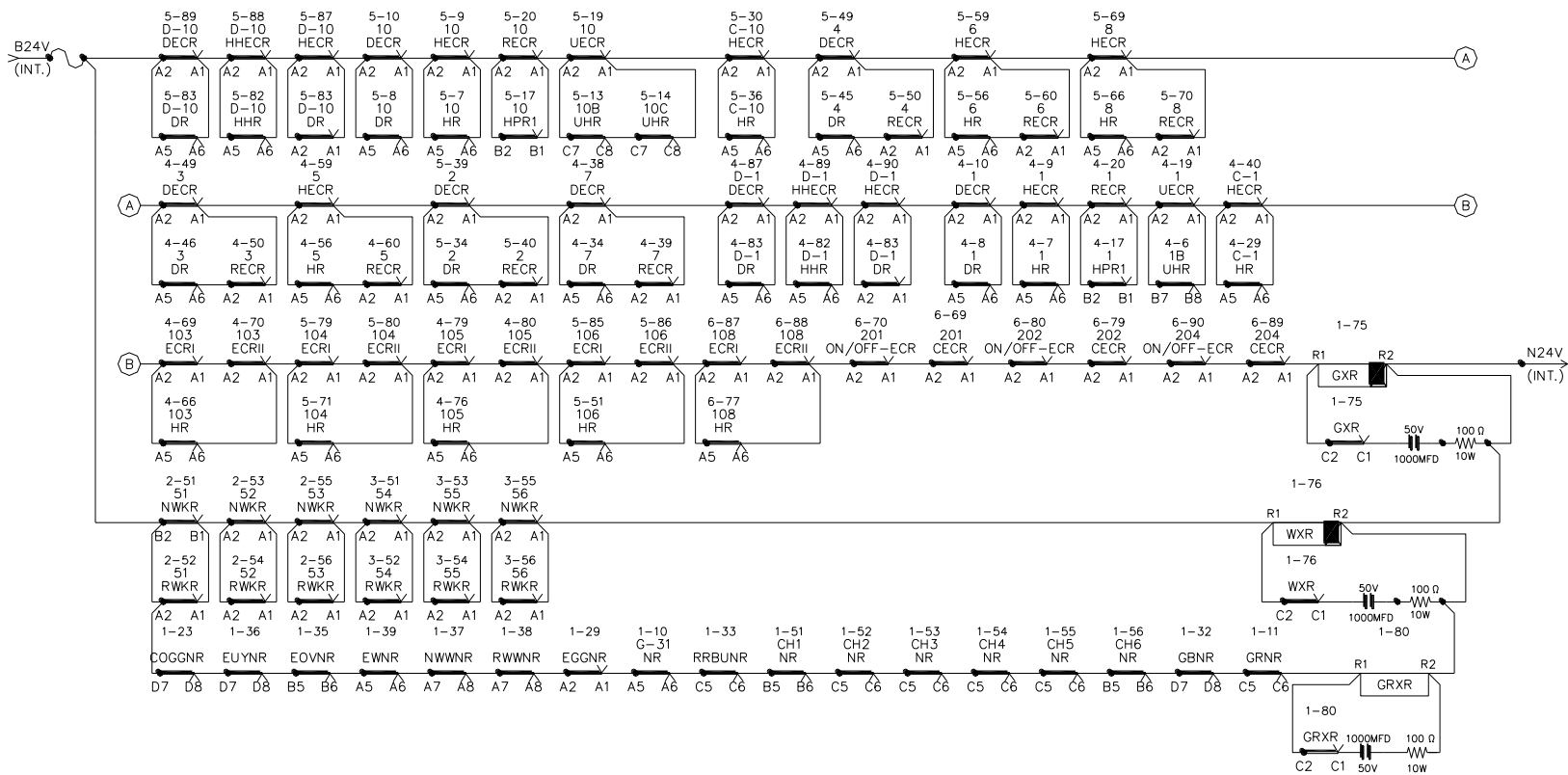

Fig : 9.8-03 – Signal, Point & Button Failure Alarm Circuits

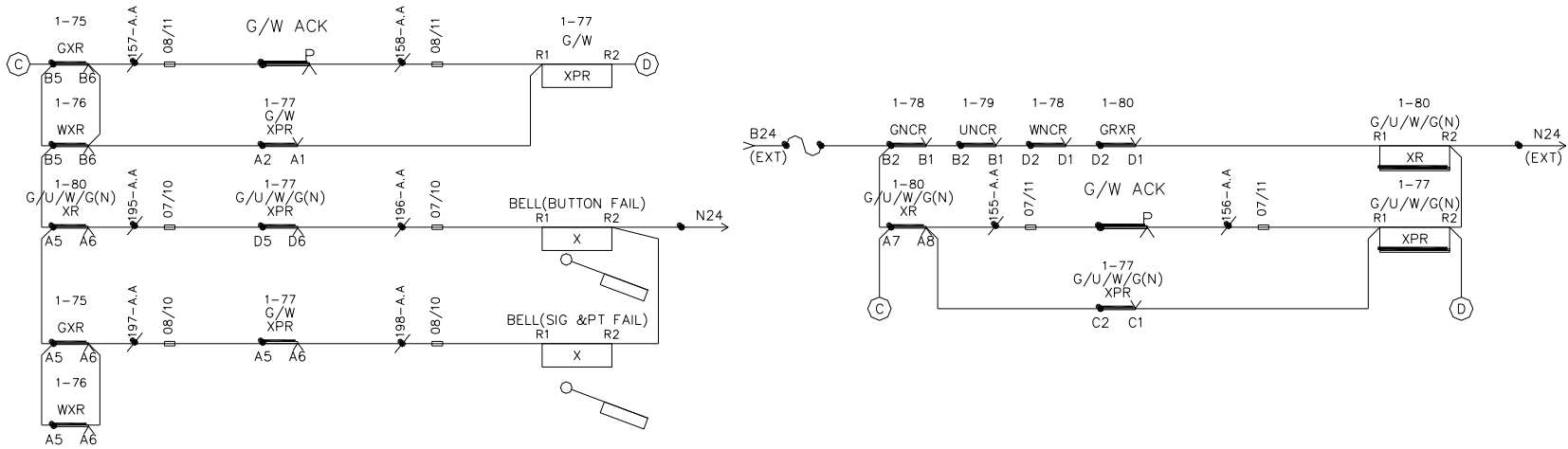

Fig : 9.8-03 – Signal, Point & Button Failure Alarm Circuits (Cont.)

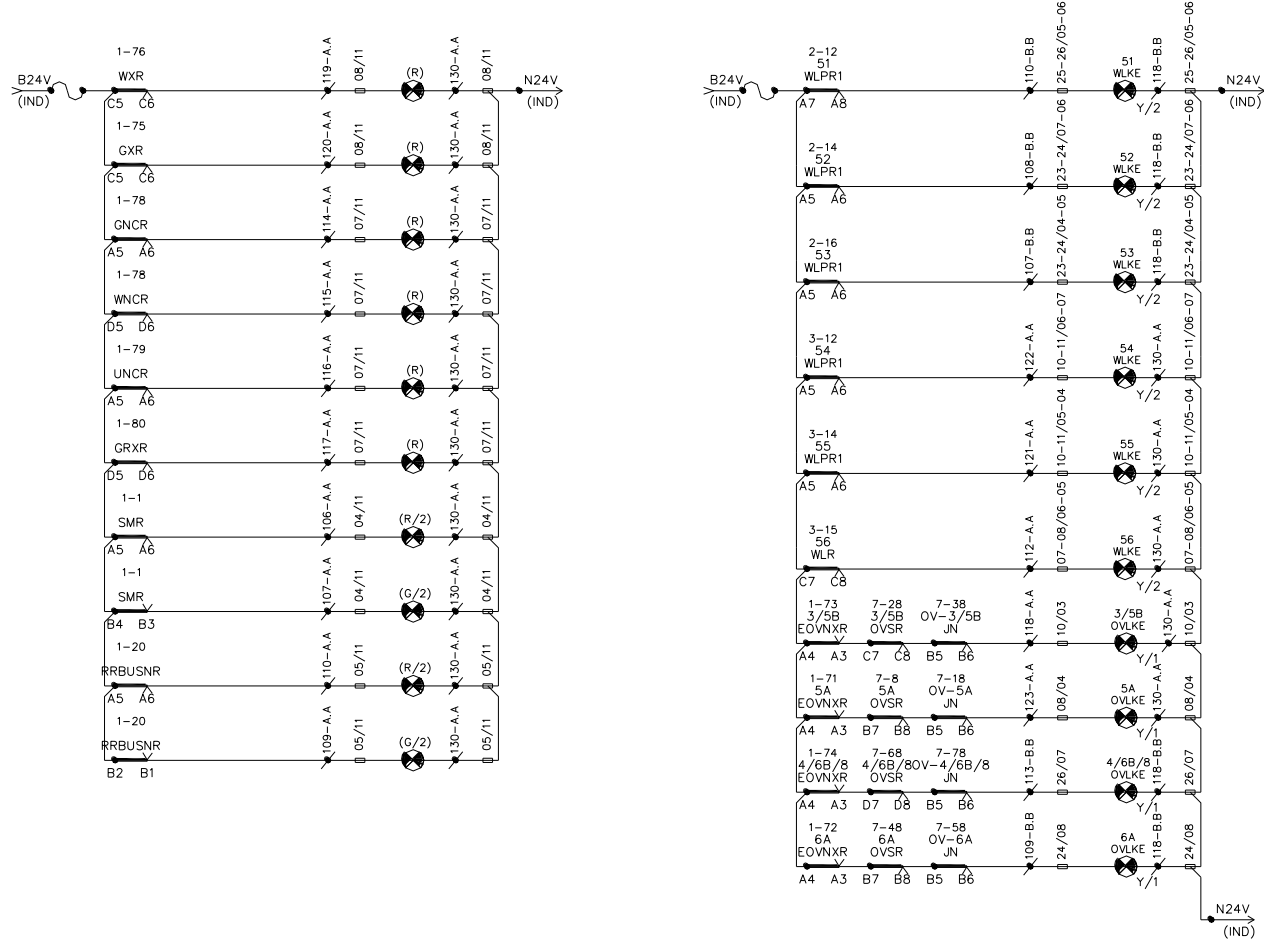

Fig : 9.8-04 – Signal, Point & Button Failure Alarm Circuits (Cont.)

9.9 Crank handle Interlocking

Circuit explanation for crank handle

CH1 Crank handle controls point no 51

When the crank handle is inside EKT, key in contact is made. KLNLR picks up proving crank handle in.

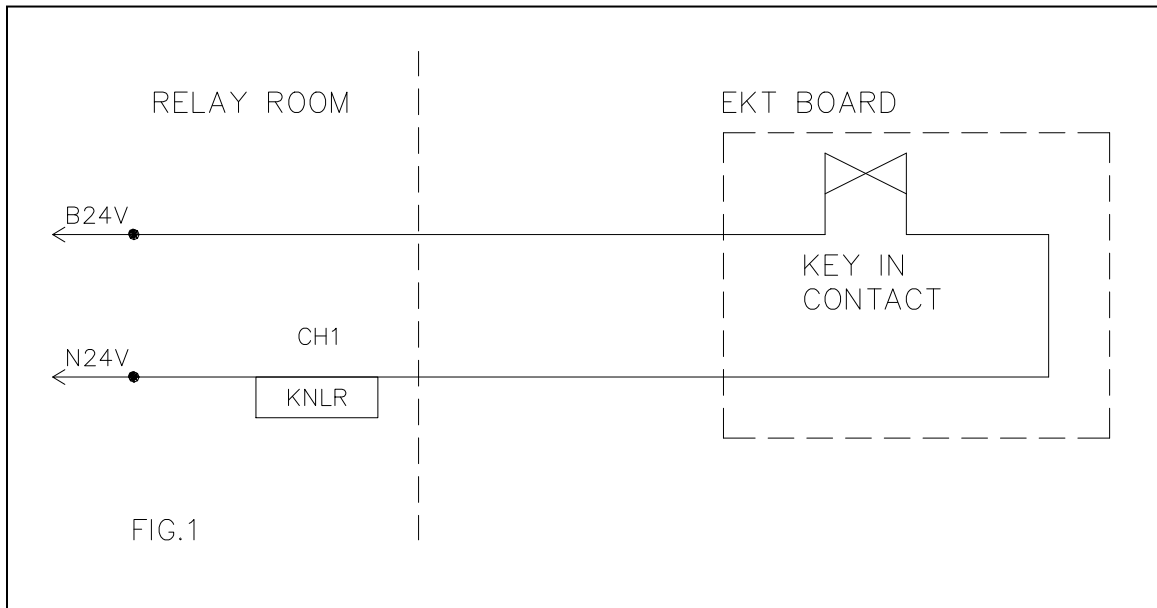

CHZ, YR relay picks up to give permission to take the handle out.

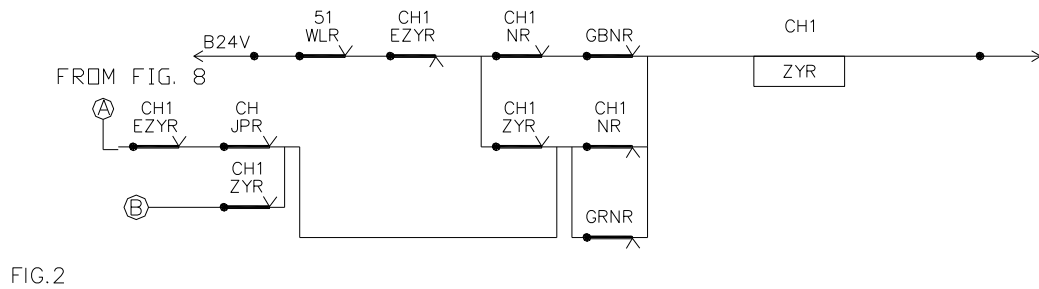

If WLRT, the point is free from any signal locking. If CH1 button and common button GBN are pressed together, CH1ZYR will pick up & hold through its own front contact, as buttons will be released.

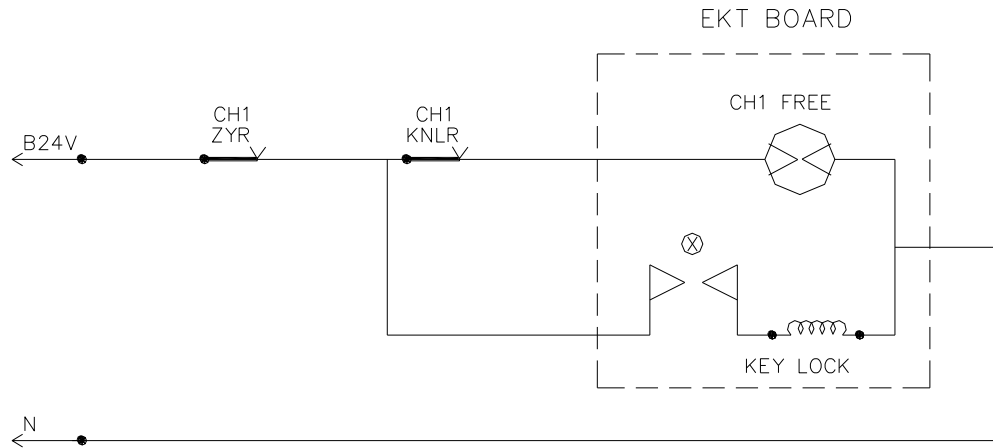

FIG.3

⊗ MAKES MOMENTARILY WHILE EXTRACTING THE THE HANDLE

On seeing free indication, ASM or person at EKT board can take the crank handle out by key lock coil getting energized. Once handle is taken out, momentary contact will break cutting off key lock coil current. KNLR also drops (see Fig 1) as removal of crank handle key opens key in contact.

So with dropping of KNLR & picking up of ZYR. ZPR drops. So no signal can be cleared or point can be operated. CH1ZPR proves crank handle in and can not be taken out. So it proves $KNLR \uparrow + CH1ZYR \downarrow$

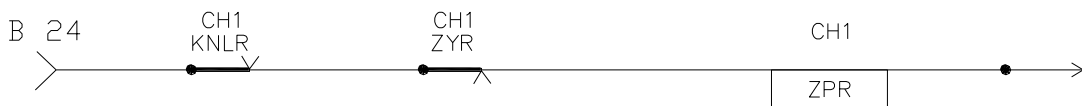

FIG.4

CH1ZPR front contact is proved in point operation circuits i.e. NWR/RWR and in signal circuits i.e. UCR

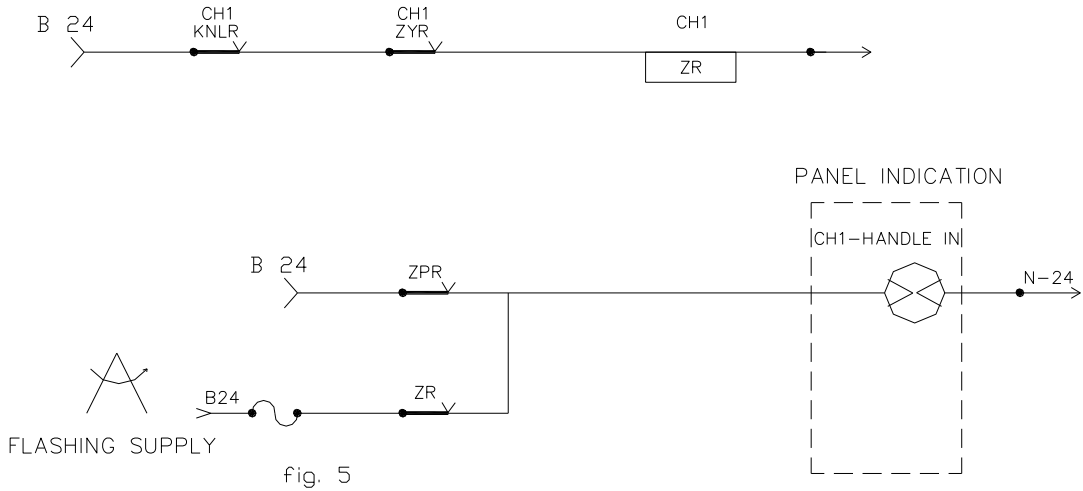

fig. 5

When ZYR \uparrow , ZR front contact makes Crank handle in indication flash, showing handle can be taken out. Once handle is taken out KNLR \downarrow , ZR \downarrow flashing indicators above stops. Now key out indication will come on panel.



FIG. 6

After the work is over on the point, crank handle will be deposited back in EKT.

With key in contact made, KNLR \uparrow . Now ZYR has to be dropped. For this ASM has to be press CH1 button & GRN button. Refer Fig.2. With CH1NR \uparrow , GRNR \uparrow , ZYR holding circuit will be broken. CH1ZYR \downarrow

With ZYR \uparrow to enable the extraction of handle, counter will operate (Refer Fig 2)

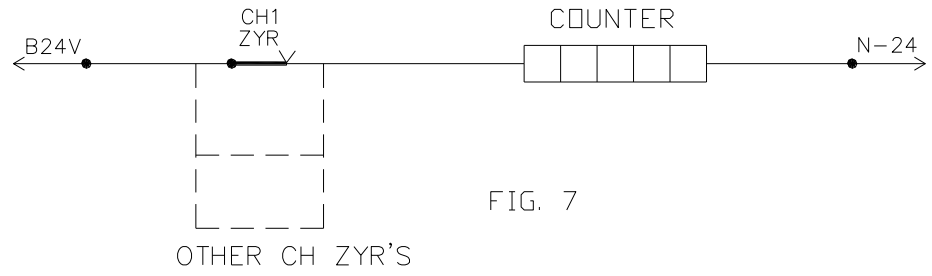

FIG. 7

Extraction of Crank handle, when point locking relay is dropped & has not picked up due to fault.

Here WLR↓ so ZYR can not pick up as per Fig. 2 directly.

First EZYR will pick up, proving all concerned signals, controlling 51 point, are normal, i.e., HR↓, UCR↓

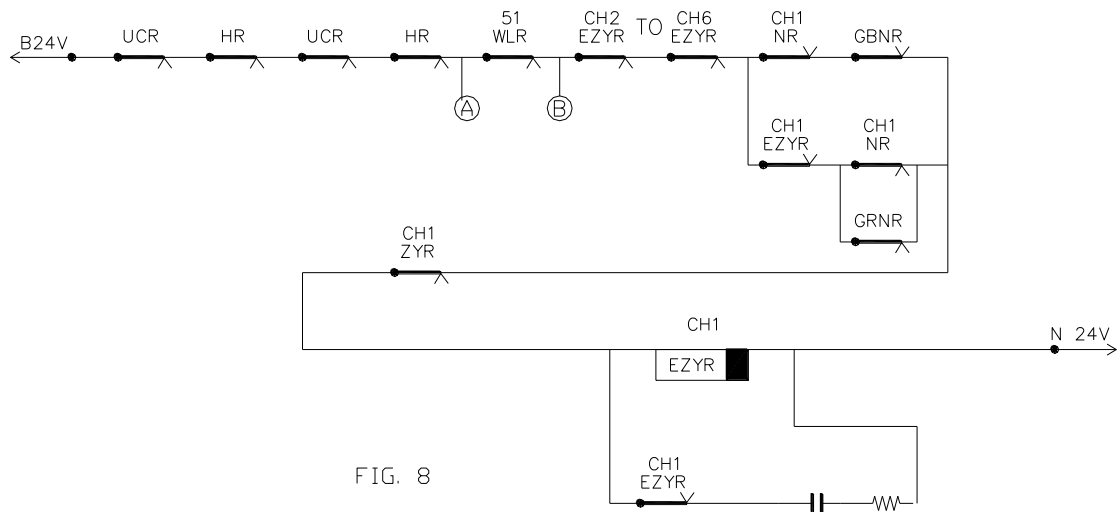
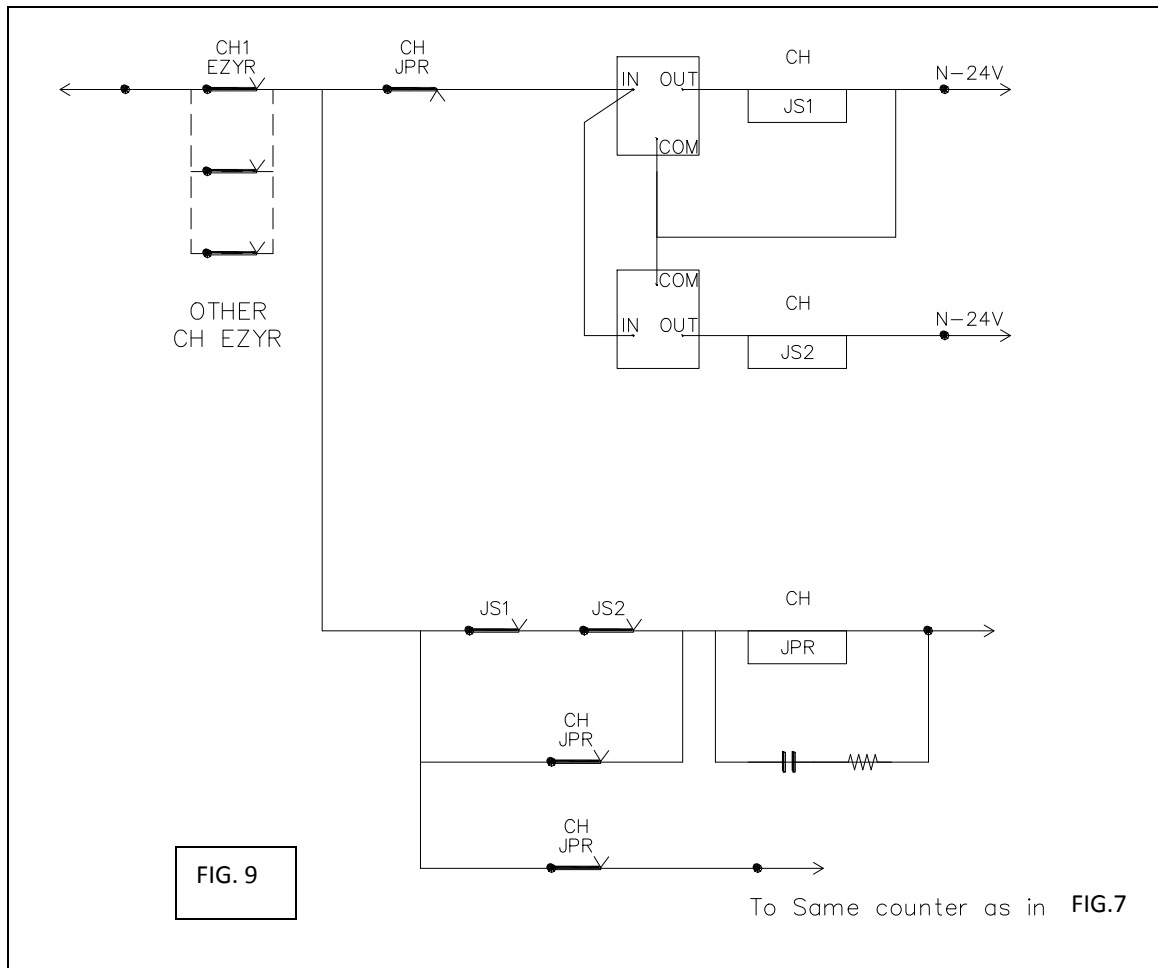

FIG. 8

When ASM presses CH1 & GBN buttons, EZYR↑.

A common timer is used for all crank handles. But at a time one crank handle alone can use it. So all other CH-EZYR↓ is proved, while picking up CH1EZYR. Then a time delay relay will be energized after 120 seconds. By this time any movement if taking place should be over.



After the time delay JS1, JS2 operate. JPR picks up. Once JPR is picked up it holds, as it cuts off supply to JS1 & JS2. JPR[↑] drives the counter on the panel.

Now refer Fig 2 & Fig 7 with CHJPR[↑] & CH1EZYR[↑], CH1ZYR will pick up. So crank handle will be taken out as explained in Fig. 3

Since CH1EZYR in Fig7 picks up through CH1ZYR[↓] as soon as CH1ZYR[↑], CH1EZYR feed will be cut off. EZYR is energized for some time to help CH1ZYR to pick up and hold through its own contact as shown in Fig.2. So CHEZYR is made to slow to release.

Now EZYR[↓] rest of circuits are same as explained earlier, as ZYR is picked up. EZYR dropping feed to JPR will be cut off. JPR will drop. JPR is made to release slowly due to the reasons explained for EZYR slow to release.

9.10 Level Crossing Interlocking

Level Crossing Interlocking Circuits

- Connected Relays:
- LXLR: This relay picks up by proving all concerned ASR/OVSRs of signals in whose route/overlap the L.C. gate falls are free.(i.e., picked up) and UCRs are de-energized (i.e., route is not set).
- LXRR: It proves that the gate is free to be opened for road traffic (i.e., LXLR is up) and gate button LXN and common (group) slot release button GBN are pressed. It proves permission is given from the panel to open the gate. Its repeater at the gate is LXRPR, the front contact of which gives feed to gate key lock to release it.
- KNLR: Proves gate key is in. i.e., gate is closed against road traffic, locked and key is kept in the place at gate lodge to transfer control to panel at the station. It is the relay in station, repeating another relay KN_R at gate site. KN_R picks up after key is deposited at site by gate man.
- LXNR: This relay proves control given to the gate has come back to panel and gate can not be opened. After KNLR picks up, panel operator presses LXN + GRN (Group slot restoration button) and LXNR picks up.
- Fig 1 gives the circuit of LXLR.
- Fig 2 gives the circuit of LXRR
- Fig 3 gives the circuit of LXRPR, a site relay.
- Fig 4 gives the circuit of LXNR
- Fig 5 gives the circuit of key extraction and restoration (i.e., pick up circuit of KN-R at gate location and KNLR at the station).If due to any technical snag, gate key can not be taken out to open the gate road traffic will get piled up at the gate. For this in a sealed box at gate site, an emergency key (EM Key)is kept

- This EM key has no lock .It is free. However it has key in contact. So when it is taken out by breaking the sealed box, its key-in contact breaks. This drops KN-R and KNLR. Since KNLR front contact is proved in all concerned signal circuits i.e. UCR, HR etc. signal can not be cleared when EM-key is out to open the gate.

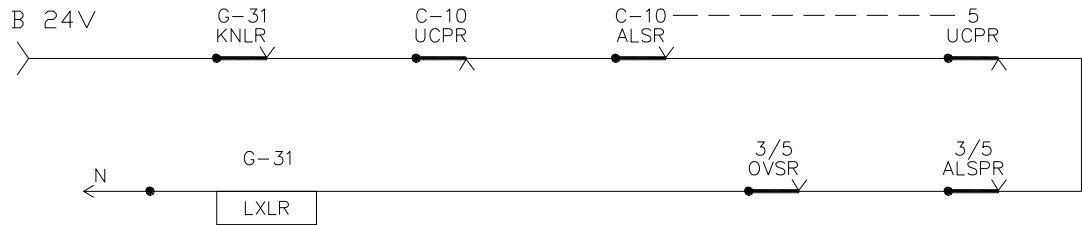

SHOWS ALL OTHER CONCERNED SIGNALS. UCR DOWN AND ALSPR UP.

FIG. 1

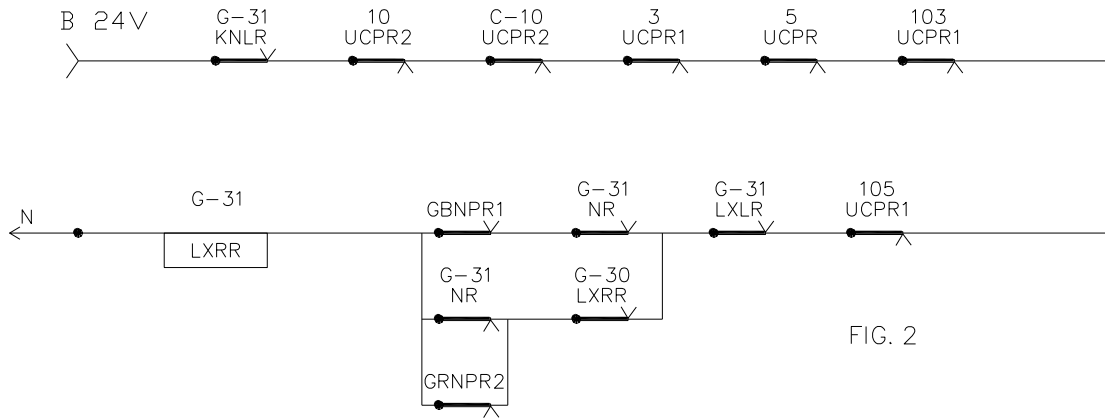
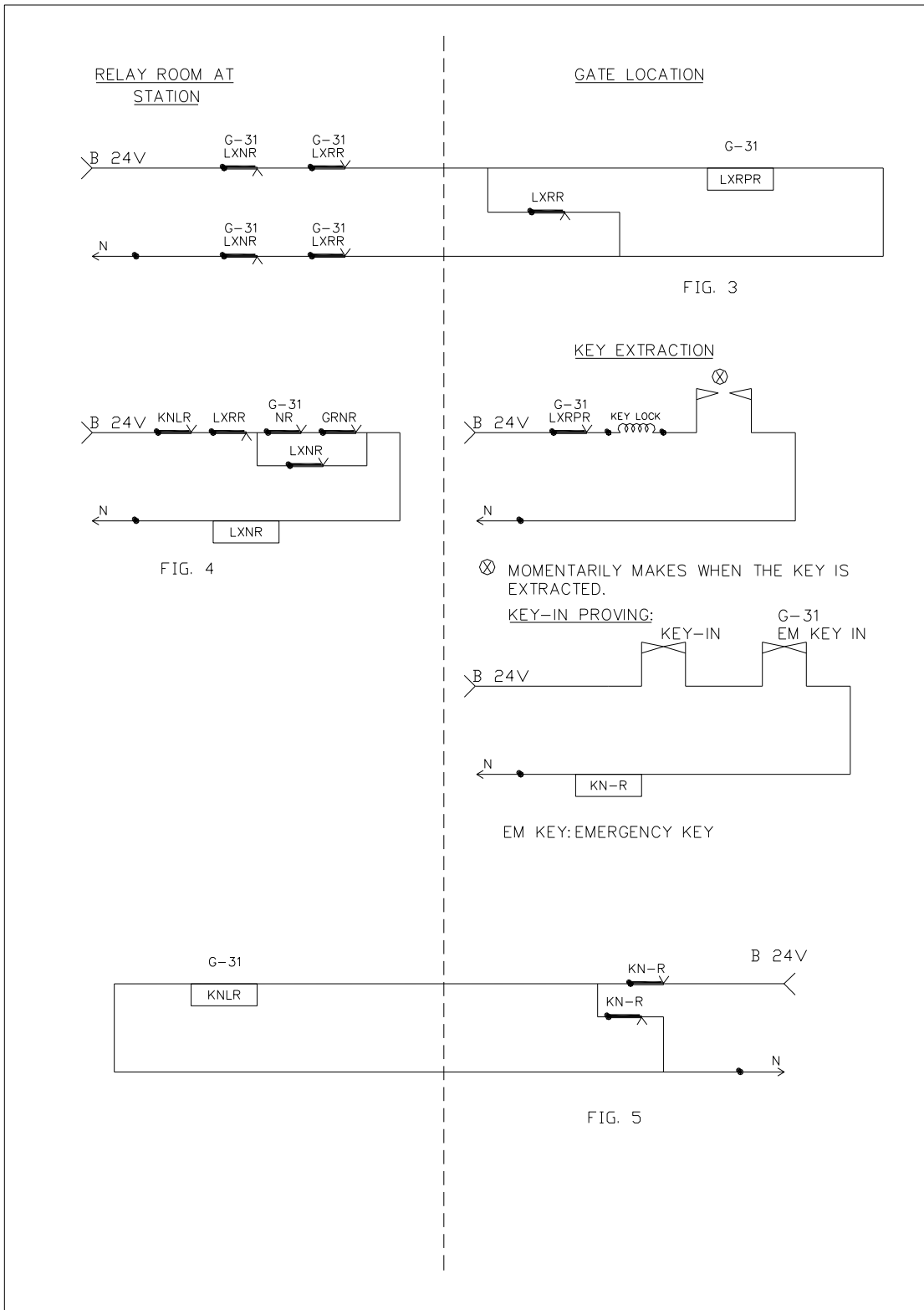

FIG. 2



Systems of Block Working

Double line block instrument interface with panel

10

Chapter

The entry of train onto the block section is jointly controlled by the entry and exit points of the block section. The driver is authorized to proceed into block section by the signal controlling the entry into the section. This working could be the ABSOLUTE BLOCK system stem or AUTOMATIC BLOCK system.

Essentials of Absolute block :

“Where trains are worked on absolute block system “

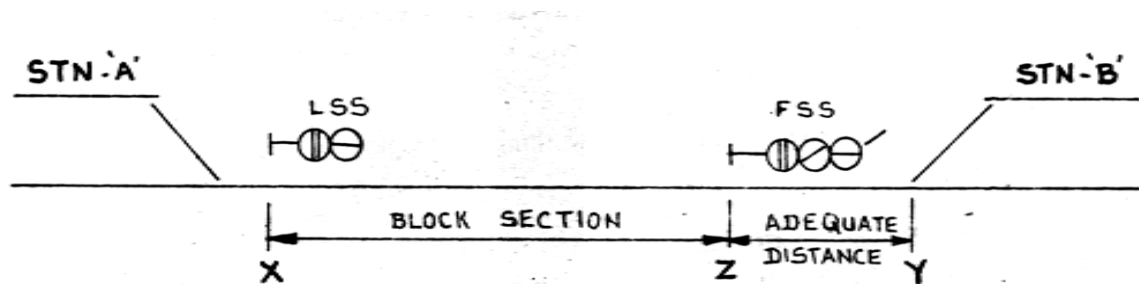

- No train shall be allowed to leave a block station unless Line clear has been received from the block station in advance, and
- On double lines, such line clear shall not be given unless the line is clear not only upto the first stop signal at the block station at which such line clear is given but also for an adequate distance beyond it .
- On single, such shall not be given unless the line is clear of trains running in the same direction not only upto the first stop signal at the block station at which such line clear is given but also for an adequate distance beyond it, and is clear of trains running in the direction towards the block section to which such line clear is given. The adequate distance referred shall not be less than 180 Mts
- The whole of the last preceding train has arrived complete; and all necessary signals have been put back to 'ON' behind the said train.

Block working on double line section

On request from sending station (station-B) station master at station-A will turn the block handle to 'Line clear' (L-C) position if he is ready to receive the train. LC contact of the block handle energizes LCR. Line clear indication (LCKE appears). The first stop signal (home) is at 'ON' (RECR↑). The relay GNSR will pick up & switches on the line circuit enabling BPR at station B to pick up. BPR is a polarized relay, thus it gets attracted to line clear side & Bottom Galvo at receiving station A & top Galvo needle indicator at station B turn to 'line clear' position. LCPR is energized through polarized relay contact on LC side provided the last stop signal displays 'ON' aspect. Advance starter can then be cleared for dispatch of train duly proving that the block section including overlap is clear (VPR-UP). When the train crosses advance starter, TPIR picks up registering train entering block section. This is accompanied with audio-visual alarm at the sending station. The buzzer can be stopped by pressing the 'ACK' button.

Information is then passed on to station A who will turn the block handle to 'TOL' position. This sends both the galvos to change to TOL position. SR at station B gets energized & remains in that state.

At the receiving station A, when the home signal 1 is cleared, ZR picks up. With the sequential proving of ITP & ITPI, BSR & BSPR pick up. Now when block section is clear on complete arrival block clear indication is given. & the block handle can be brought to 'line closed' position thereby, completing the block operation.

In the event of failure to turn the handle to TOL upon train entering section, auto TOL feature has been incorporated. As a result TOLR will be picked up when train arrives, ASM gets auto-TOL buzzer / indication. Station master at station A will be forced to turn the handle to TOL. Then through special contact of TOL, BTSR relay picks up. This will in-turn energise the lock and instrument can be turned to line clear from TOL. This operation is recorded by an electronic counter in addition to audio-visual alarm. Detailed circuit of the block working is shown below.

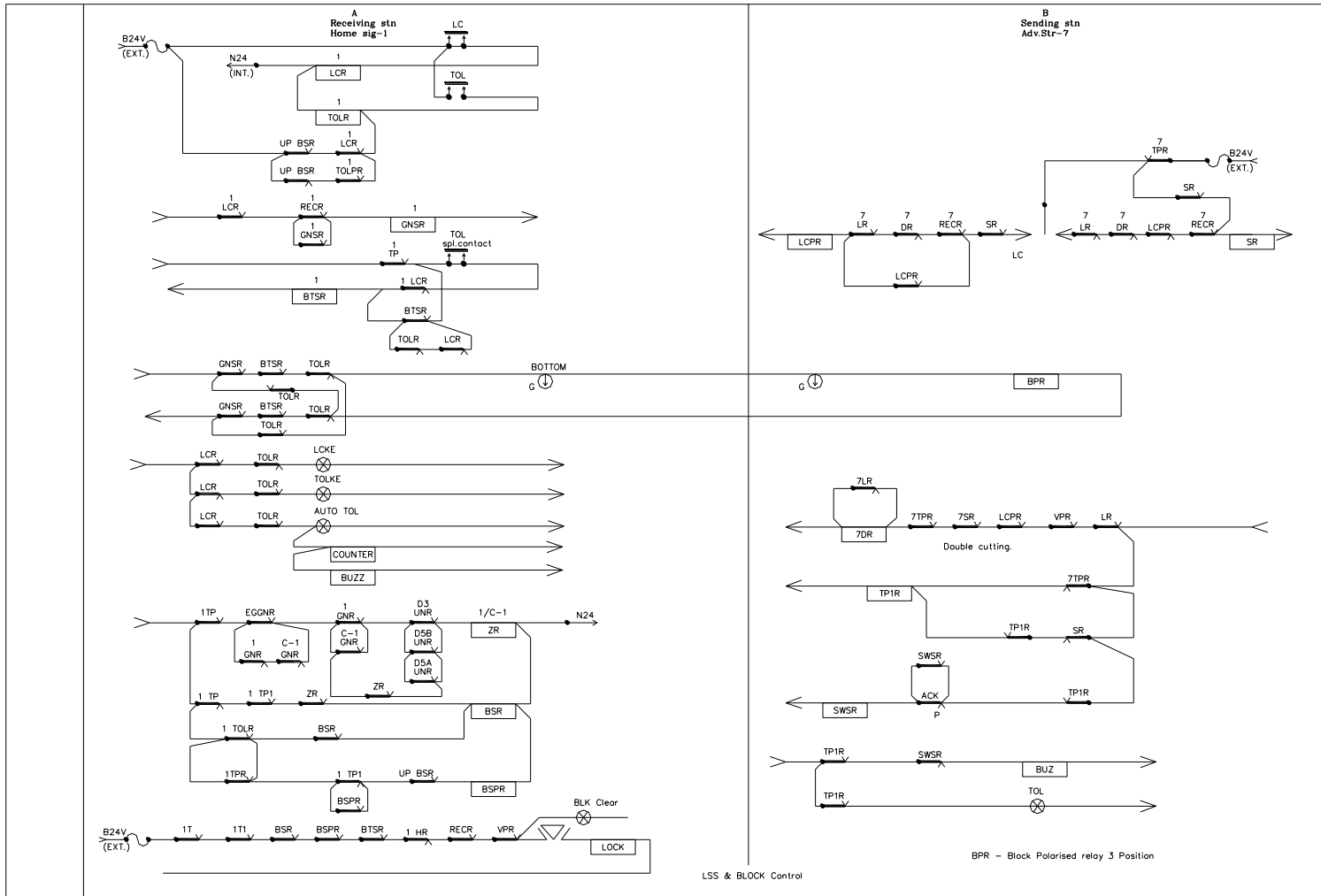

Fig : 10.01 – Block Circuits

Planning for Outdoor Cable requirement

11

Chapter

Requirement of cable conduction is to be determined depending upon the circuits run from CT Room /Relay room function.

Separate cable line wise and if necessary, function wise are laid from relay room /CT room to facilitate easy testing of cable without much distraction to the traffic.

Cable size to be determined keeping spare conductors to a minimum of 20% of total conductors used in each cable wiring between the outermost facing point of the station and minimum of 10% of the total conduction used in the each cable working beyond the points area upto the outermost signals.

The approximate cable requirement for a typical four line station on a double line section and a 3 line station on a single line section.

Type of cable	Double line	Single line
Signalling cable 24 core	9 kms.	1 kms
Signalling cable 19 core	10.6 kms.	2.4 kms
Signalling cable 12 core	10.5 kms	12.7 kms
Signalling cable 6 core	5.7 kms.	3.3 kms
Power cable 10 Sq	8.6kms.	7.7 kms

(Aluminum conductor)

Numbering of cable is done in ascending order right hand side of the cable core distribution plan

A cable distribution plan for a 4 line station on a double line section is attached for reference.

Another Design approach for Major Yards

12

Chapter

Route Selection in Major Yards

For Major yards, where number of shunt signals is more, there are signals that control too many routes and same point falls in many routes, Route selection and control of points become too complex in view of unmanageable number of LRs and unwieldy design of point control circuits. The route selection circuit is drawn in two parts in a geographical manner. The circuit commences from the signal button relay and advances in the direction of movement up to the end of the route, the circuit then folds back and completes at the entry signal end.

Each end of the points is provided with two relays CR &NR for normal operation and a common RR for operation to reverse. Thus, every cross-over point is provided with five relays ANR, ACR, BNR, BCR, and RR for controlling its operation.

While progressing in the forward flow, the availability of the route is checked. When a trialing point is encountered in the normal position, it is proved that the points are not used by any other route requiring these points in reverse position and the respective CR (Checking Relay) is energized. This CR relay prevents any other conflicting route being initiated

When facing points are encountered in the forward flow circuit it is ensured that the points are not used for reverse. No checking relay is picked up in this forward flow circuit, but these points will have their CR & NR relays picked up in the return direction. When the route involves points in reverse position, circuit for RR is either prepared in the forward flow circuit and operated after ensuring the entire route is free or prepared and operated in the return circuit. Thus the forward flow circuit extends proving the availability of route to the exit end through the exit button operated contacts.

When the exit button relay operates, the circuit folds back and extend towards the entrance end. The conditions proved are exactly similar to the forward flow circuit. As stated already the trailing points in the return direction have their CR and NR operated. Where the route is through reverse setting of points, RR relays of relevant points are energized.

The operation of point control relays NR & RR is done sequentially in the return direction irrespective of whether they are facing or trailing. The first point NR or RR in return direction is controlled by the exit button relay. The second point NR or RR is energized by the first point NR or RR relay, the third point NR or RR by the second point relays and so on and the desired route is set. Except for Route selection and point control, the principle of Route checking, Route locking & holding, signal control circuits and Route release remain the same.