

ERTMS/ETCS

ERTMS EuroRadio Test cases Safety Layer

REF : SUBSET-092-2

ISSUE : 3.1.0

DATE : 18-Dec-2015

Company	Technical Approval	Management approval
ALSTOM		
ANSALDO		
AZD		
BOMBARDIER		
CAF		
SIEMENS		
THALES		

1. MODIFICATION HISTORY

Issue Number Date	Section Number	Modification / Description	Author
0.1.0 2001-Nov-15	All	First example of test cases	T. Streich
0.2.0 2002-Jan-24	All		T. Streich
0.3.0 2002-03-08	All	Test architecture modified, figures and test cases added (up to section 5.3.5)	T. Streich
0.4.0 2002-04-18	All	Test cases completed Error codes changed according to Brussels meeting, figures and test cases added Behaviour of former field "reserved" changed Covered items, introduction and overview added	T. Streich
0.4.1 2002-04-18	All	Identical to version 0.4.0, but clean version (without revision remarks)	T. Streich
0.4.2 2002-04-19	All	English check	J. Harmer
0.5.0 2002-05-06	All	Version for external review, changes according to final discussion at Budapest meeting	T. Streich
0.5.1 2002-05-06	All	Identical to version 0.5.0, but clean version (without revision remarks)	T. Streich
0.6.0 2002-05-13	3.3	Update of reference [2]	T. Streich
2.2.1 2002-06-27	3.1	Update according to review comments of ASNv: <ul style="list-style-type: none"> • Introduction • section numbering 	T. Streich

Issue Number Date	Section Number	Modification / Description	Author
2.2.1+	5.3.3 5.4.2 5.4.4 5.4.5	Subreason changed to subreason 3 (harmonisation with definition of subset 37) Update according to modified state table of subset-037 issue 2.2.1+: error reaction changed to Disconnect, figure deleted Message length of DT SaPDU (too long) changed to the threshold value (also too long) Deleted (not specified in FIS)	TS
2.2.2 31-03-03		Version number raised for release to the users Group	JH
2.2.3 20-06-2003	3.3 5.3.6 5.4.6	Update of references Subreason changed SA-report.indication marked as optional Editorial changes	TS
2.2.4 26-06-2003	-	Clean version of issue 2.2.3	TS
2.2.5 18-07-2003	-	Final edition	TS
2.2.5revA 31-08-2005		Update to subset 037 issue 2.2.5revF	TS
2.2.5revB 21-10-2005		Update to Subset037 issue 2.3.0 and Subset092-1revC	TS
2.2.5revC 09-11-2005	5.2.20	corrections after comments at ER meeting	VP
2.3.0 06-02-2006	-	Formal release	VP
2.3.0 30-03-2009	all sections renumbered	Template updated	JH
2.3.1 19-07-2011		Change references to ss-037 and ss-092-1	XM

Issue Number Date	Section Number	Modification / Description	Author
2.4.0-3 4-10-2011	All	after final wg review	JH
2.4.4 12-12-2011	-	release for review	ER WG
2.4.5 23-02-2012	Cover, § 3.3	CR1135	XM
3.0.0	-	Baseline 3 release version	ER WG
3.0.1 2-Dec-2015	5.2.12, 5.3.9 3.2, 5.2.3, 5.2.8, 5.2.10, 5.2.15, 5.2.19, 5.3.2-8, 5.3.10-14, 5.4.1, 5.4.3-6, 5.6.2, 6.1.1.3	deleted Error corrections and updates	ER WG
3.1.0 18-Dec-2015	-	Baseline 3 2 nd release version	ER WG

2. TABLE OF CONTENTS AND FIGURES

1. MODIFICATION HISTORY.....	2
2. TABLE OF CONTENTS AND FIGURES.....	5
3. INTRODUCTION.....	8
3.1 Scope.....	8
3.2 Abbreviations	8
3.3 References	9
3.4 Definitions	9
4. TEST ARCHITECTURE	10
5. TESTCASE DESCRIPTION.....	11
5.1 Configuration data of IUT	11
5.2 Connection establishment (outgoing request)	12
5.2.1 Normal order of events	12
5.2.2 Normal order of events – Use of default parameters.....	13
5.2.3 Error case - Time out of Timer T_{estab} after AU3 SaPDU.....	14
5.2.4 Error case - Time out of Timer T_{estab} after AU1 SaPDU	16
5.2.5 Error case – Connect request with wrong application type.....	17
5.2.6 Error case – Reception of an AU2 SaPDU with an unexpected responding ETCS-ID 17	17
5.2.7 Error case – Reception of an AU2 SaPDU with MAC error	18
5.2.8 Error case – Reception of an AR SaPDU with MAC error	20
5.2.9 Error case – Reception of an AU2 SaPDU with wrong direction flag.....	21
5.2.10 Error case – Reception of an AR SaPDU with wrong direction flag.....	22
5.2.11 Error case – Reception of an AU2 SaPDU with wrong ETY field.....	23
5.2.12 Intentionally deleted.	24
5.2.13 Error case – Reception of an AU2 SaPDU with not supported safety feature	24
5.2.14 Error case – Sequence error after AU1 SaPDU	25
5.2.15 Error case – Transport Connection Confirmation without AU2 SaPDU	25
5.2.16 Error case – Sequence error after AU3 SaPDU	27
5.2.17 Error case – Reception of an AU2 SaPDU with wrong length	28
5.2.18 Error case – Reception of an AR SaPDU with wrong length	29
5.2.19 Error case – Revocation of a connect request during peer entity authentication	30
5.2.20 Error case – No transport connection available.....	32
5.3 Connection establishment (incoming request)	33
5.3.1 Normal order of events	33
5.3.2 Error case - Missing authentication key.....	35

5.3.3	Error case – Reception of an AU3 SaPDU with MAC error	37
5.3.4	Error case – Reception of an AU1 SaPDU with wrong direction flag	38
5.3.5	Error case – Reception of an AU3 SaPDU with wrong direction flag	39
5.3.6	Error case – Reception of an AU1 SaPDU with wrong field ETY	40
5.3.7	Error case – Reception of AU3 SaPDU with changed first octet	40
5.3.8	Error case – Reception of an AU1 SaPDU with not supported safety feature	40
5.3.9	Intentionally deleted	41
5.3.10	Error case – Sequence error during peer entity authentication (reception of first message)	41
5.3.11	Error case - Error during peer entity authentication (first message missing)	42
5.3.12	Error case - Sequence error during peer entity authentication (reception of third message)	43
5.3.13	Error case – Reception of an AU1 SaPDU with wrong length	44
5.3.14	Error case – Reception of an AU3 SaPDU with wrong length	45
5.3.15	Error case – Incoming connect indication is not confirmed by SaS user	46
5.4	Transfer of normal and high priority data	47
5.4.1	Normal order of events	47
5.4.2	Error case – Reception of messages with a wrong MTI	49
5.4.3	Error case – Reception of DT SaPDU, which is too short.....	50
5.4.4	Error case – Reception of DT SaPDU, which is too long.....	51
5.4.5	Error case – Reception of DT SaPDU with wrong direction flag	51
5.4.6	Error case – Reception of DT SaPDU with wrong direction flag	52
5.4.7	Error case – Reception of DT SaPDU with wrong MAC	53
5.5	Disconnect request (outgoing request)	55
5.5.1	Normal order of events	55
5.6	Disconnect request (incoming request)	56
5.6.1	Normal order of events	56
5.6.2	Error case - No transport service available	57
5.6.3	Error case – Reception of an DI SaPDU with wrong direction flag	57
5.6.4	Error case – Reception of an DI SaPDU with changed first octet	58
6.	OVERVIEW OF TEST CASE BEHAVIOUR.....	60

Table of figures

Figure 1 – Test architecture	10
Figure 2 – Connection establishment (outgoing request) – normal order of events.....	13
Figure 3 – Time out T_{estab}	15
Figure 4 – Time out T_{estab}	17
Figure 5 – Reception of unacceptable AU2 SaPDU	18
Figure 6 – Reception of an unacceptable AR SaPDU	21
Figure 7 – T-Conn.conf without user data	26
Figure 8 – Revocation during safe connection establishment.....	31
Figure 9 – Revocation during safe connection establishment.....	31
Figure 10 – No transport connection available	33
Figure 11 – Normal order of events (incoming connect request)	34
Figure 12 – Reception of an unacceptable AU1 SaPDU	36
Figure 13 – Reception of an unacceptable AU3 SaPDU	38
Figure 14 – Reception of an unacceptable T-conn.ind	43
Figure 15 – Normal order of events (incoming connect request not confirmed)	47
Figure 16 – Data transfer	49
Figure 17 – Reception of a wrong DT SaPDU.....	50
Figure 18 – Reception of DT SaPDU with wrong MAC.....	54
Figure 19 – Disconnect request (outgoing request).....	55
Figure 20 – Disconnect request (incoming request)	56
Figure 21 – Disconnect request (incoming request) – no transport service available	57
Figure 22 – Structure of a state transition	60
Figure 23 – Overview about test cases and input / output states	61

3. INTRODUCTION

3.1 Scope

- 3.1.1.1 These test cases are part of the conformance testing of EURORADIO. The purpose of conformance testing is to provide assurance that different EuroRadio sub-systems implementations are able to interwork and to secure the safety of a train control system consisting of components from different suppliers.
- 3.1.1.2 Part 1 of this UNISIG subset 092 defines therefore items which have to be guaranteed of the different implementations to ensure interoperability.
- 3.1.1.3 Because of the impact of the safety layer on the safety of the whole ETCS system this document provides test cases for the safety layer. Therefore a common behaviour against error events can be assumed by all conformance tested Euroradio safety layers from different providers.
- 3.1.1.4 The definition of test cases in this document does not include testing of performance requirements and quality rules. Fulfilments of such requirements have to be proved at the level of the component or sub-system, where the Euroradio protocols are integrated (e.g., on-board ETCS equipment or RBC).
- 3.1.1.5 Test cases covering the items of the CFM are not provided. Company specific test cases are recommended taking into account testing experience of existing solutions from different industry standards.

3.2 Abbreviations

3.2.1.1 For the purposes of this test case definition the following definitions apply:

Abbreviations	Contents of the abbreviation
AR	Authentication Response
AU1	First Authentication message
AU2	Second Authentication message
AU3	Third Authentication message
CFM	Communication Functional Module
DI	Disconnect
DT	Data
Estab	Establishment
ETY	ETCS ID type field in a SaPDU

Abbreviations	Contents of the abbreviation
ID	Identity
IUT	Implementation under Test
IUT with OBU role	Implementation under Test which will be used in an OBU
IUT with RBC role	Implementation under Test which will be used in an RBC
PCO	Point of control and observation
SaPDU	Safety Protocol Data Unit
SaS	Safety service
SFM	Safe Functional Module
TC	Test case

3.3 References

- [1] ERTMS/ETCS; Subset 037; EuroRadio FIS
 [2] ERTMS/ETCS; Subset 092-1, ERTMS EuroRadio Conformance Requirements

3.4 Definitions

3.4.1.1 For the purposes of this test case definition the following definitions apply:

Used term	Explanation
DATA	State according to [1] section 7.2.5.3.1. Safety connection is opened and ready for data transfer during this state.
IDLE	State according to [1] section 7.2.5.3.1. Safety connection is closed or does not exist during this state.
Requested pattern	Predefined user data, available at SaS user as well as at test environment for the test of data transfer Transmitted data can be compared after reception with expected data due to the knowledge of this requested pattern

4. TEST ARCHITECTURE

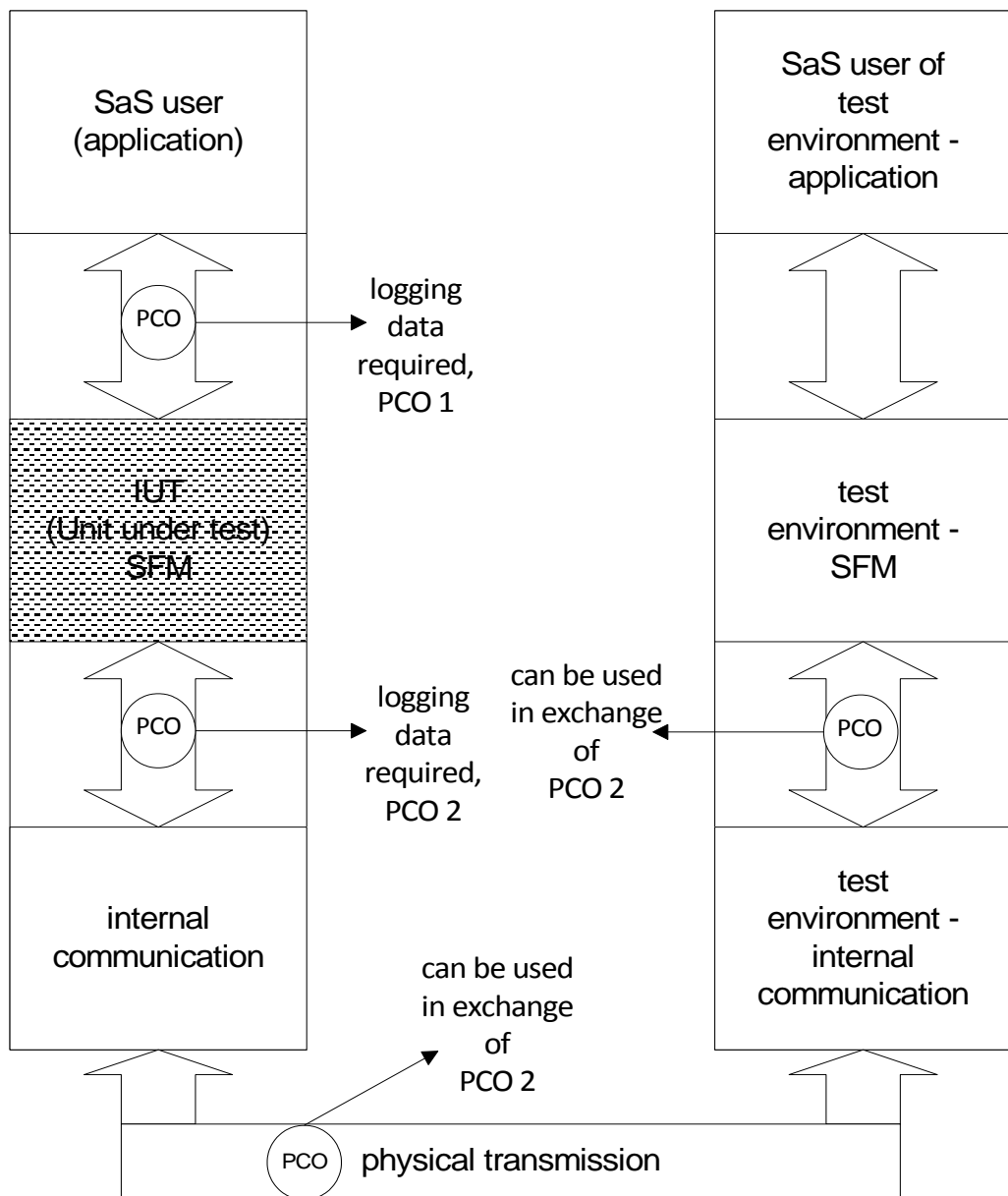

Figure 1 – Test architecture

- 4.1.1.1 Figure 1 contains a possible test architecture. The following descriptions of the test cases (section 5) always refer to the Protocol data units and Primitives of PCO 1 and PCO 2. If PCO 2 is exchanged with another PCO of figure 1, the T-Primitives have to be converted.
- 4.1.1.2 The test cases assume use of the EURORADIO safety layer as part of the onboard equipment as well as the RBC component. If the IUT should be used only for one of these, the recommended configuration data for the field ETY can be changed. Test case 21 can be reduced to the corresponding pattern of configuration data.

5. TESTCASE DESCRIPTION

5.1 Configuration data of IUT

5.1.1.1 Each IUT will be used after successful test execution as a certain type of ETCS equipment. For the execution of the test cases the IUT have to use the ETCS-ID type according to its subsequent use.

5.1.1.2 If there are several possibility of subsequent use (e.g. the same implementation is used inside RBC and OBU), it is recommend to executing the test cases with all possible configuration values for the ETCS-ID type. At least the execution of the test cases inside section 5.2.1, 5.2.2 and 5.3.1 with all possible configuration values for the ETCS-ID type is required.

5.1.1.3 The ETCS-ID type of test environment has to be configured like a corresponding entity of the selected ETCS-ID type.

5.1.1.4 The own ETCS-ID should be configured according a real existing ETCS-ID value, the same value can be used for all test cases.

5.1.1.5 The value of the configured safety feature is the bit sequence '0000 0001'.

5.1.1.6 Example of configuration data of IUT:

- ETCS-ID type='001';
- safety feature ='0000 0001';
- own ETCS-ID='0x12 34 56'

5.1.1.7 Example of configuration data of test environment:

- ETCS-ID type='010';
- safety feature ='0000 0001';
- own ETCS-ID='0x98 76 54'

5.2 Connection establishment (outgoing request)

5.2.1 Normal order of events

Header	Connection establishment – outgoing request
TC No.:	1
TC covers the following items of [2]:	
	Sa 1, Sa 4, Sa 12, Sa 13, Sa 14, Sa 15, Sa 16, Sa 17, Sa 18, Sa 19, Sa 20, Sa 21, Sa 100, Sa 101A, Sa 102, Sa 104
	Approval of the following items during sending:
	Sa 31A, Sa 32, Sa 33, Sa 34, Sa 35, Sa 36, Sa 44, Sa 45, Sa 46, Sa 47
	Approval of the following items during receiving:
	Sa 37B, Sa 38, Sa 39, Sa 40, Sa 41, Sa 42, Sa 43, Sa 48, Sa 49, Sa 50, Sa 51
Test summary	
To test the successful establishment of a connection	
Test preamble	
The IUT and the test environment have to be brought into the IDLE state.	
Constraints	
Keys according to used ETCS-ID's are available and configured according to a pre-defined key value.	
Test body	
<ul style="list-style-type: none"> - The IUT receives a Sa-Conn.req (including called address, calling address, application type, QoS). - The IUT generates a T-Conn.req containing an AU1 SaPDU - The test environment accepts the request and answer with a T-Conn.resp containing an AU2 SaPDU - The IUT receives the T-Conn.conf containing this AU2 SaPDU. - The IUT generates a T-Data.req containing an AU3 SaPDU. - The test environment answers with a T-Data.req containing an AR SaPDU. - The IUT receives the T-Data.ind containing this AR SaPDU. - Connection establishment is indicated to the SaS user by Sa-Conn.conf primitives. 	
Verdict criteria	
If the SaPDU's and the Sa-Primitives conform to the requested pattern => PASS	
Test postamble	
The IUT and the test environment are in the DATA state.	
Comment	
See Figure 2	

Table 1 – Connection establishment (outgoing request)

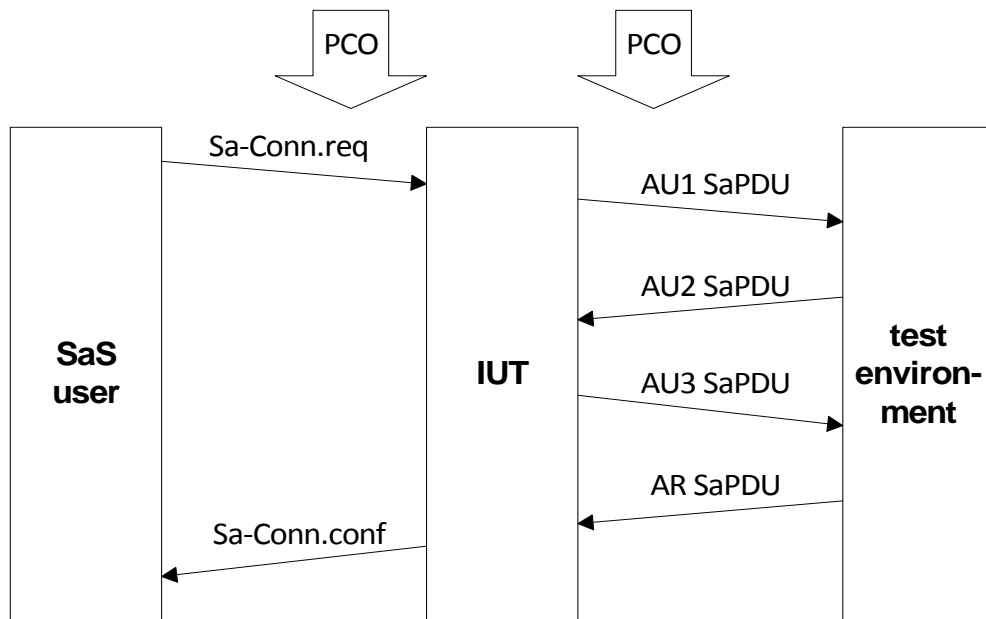

Figure 2 – Connection establishment (outgoing request) – normal order of events

5.2.2 Normal order of events – Use of default parameters

Header	Connection establishment – outgoing request
TC No.:	2
TC covers the following items of [2]: :	Sa 1, Sa 4, Sa 12, Sa 13, Sa 14, Sa 15, Sa 16, Sa 17, Sa 19, Sa 20, Sa 21, Sa 100, Sa 101B, Sa 102, Sa 104 Approval of the following items during sending: Sa 31B, Sa 32, Sa 33, Sa 34, Sa 35, Sa 36, Sa 44, Sa 45, Sa 46, Sa 47 Approval of the following items during receiving: Sa 37A, Sa 38, Sa 39, Sa 40, Sa 41, Sa 42, Sa 43, Sa 48, Sa 49, Sa 50, Sa 51
Test summary	To test the successful establishment of a connection with a default ETCS-ID's (on-board calls an unknown RBC).
Test preamble	The IUT and the test environment have to be brought into the IDLE state.
Constraints	Keys according to used ETCS-ID of the test environment are available and configured according to a pre-defined key value.
Test body	- The IUT receives a Sa-Conn.req (including at least application type and called ETCS-ID

<p>“unknown”(0xFFFFFFFF)).</p> <ul style="list-style-type: none"> - The IUT generates a T-Conn.req containing an AU1 SaPDU - The test environment accepts the request and answers with a T-Conn.resp containing an AU2 SaPDU (real responding ETCS-ID). - The IUT receives the T-Conn.conf containing this AU2 SaPDU. - The IUT generates a T-Data.req containing an AU3 SaPDU. - The test environment answers with a T-Data.req containing an AR SaPDU. - The IUT receives the T-Data.ind containing this AR SaPDU. - Connection establishment is indicated to the SaSuser by Sa-Conn.conf (including real responding ETCS-ID) primitives.
<p>Verdict criteria</p> <p>If the SaPDU and Sa-Primitives conform to the requested pattern => PASS</p>
<p>Test postamble</p> <p>The IUT and the test environment are in the DATA state.</p>
<p>Comments</p> <p>See Figure 2</p>

Table 2 - Testcase 02 – Connection establishment (outgoing request)

5.2.3 Error case - Time out of Timer T_{estab} after AU3 SaPDU

<p>Header time out of Timer T_{estab}</p> <p>TC No.: 3</p> <p>TC covers the following items of [2]:</p> <p style="padding-left: 40px;">Sa 1, Sa 8, Sa 12, Sa 13, Sa 14, Sa 15, Sa 17, Sa 18, Sa 19, Sa 20, Sa 98, Sa 100, Sa 101B, Sa 102, Sa 103, Sa 104</p> <p style="padding-left: 40px;">Approval of the following items during sending:</p> <p style="padding-left: 80px;">Sa 31B, Sa 32, Sa 33, Sa 34, Sa 35, Sa 36, Sa 44, Sa 45, Sa 46, Sa 47, Sa 57, Sa 58, Sa 59A, Sa 60, Sa 61</p> <p style="padding-left: 40px;">Approval of the following items during receiving:</p> <p style="padding-left: 80px;">Sa 37A, Sa 38, Sa 39, Sa 40, Sa 41, Sa 42, Sa 43</p>
<p>Test summary</p> <p>To test the time out of t_{estab}</p>
<p>Test preamble</p> <p>The IUT and the test environment have to be brought into the IDLE state.</p>
<p>Constraints</p> <p>SaS user of test environment does not accept incoming connect request immediately.</p>
<p>Test body</p> <ul style="list-style-type: none"> - The IUT receives a Sa-Conn.req (including called address, calling address, application type,

<p>QoS).</p> <ul style="list-style-type: none"> - The IUT generates a T-Conn.req containing an AU1 SaPDU. - The test environment (EURORADIO part) accepts the request and answers with a T-Conn.resp containing an AU2 SaPDU. - The IUT receives the T-Conn.conf containing this AU2 SaPDU. - The IUT generates a T-Data.req containing an AU3 SaPDU. - The test environment (SaS user) does not accept the incoming Sa-Conn.ind (no answer or delayed answer with delay > T_{estab}). - After T_{estab} the IUT indicates the time out of T_{estab} by Sa-Disc.ind and DI SaPDU (both with reason 7 subreason 3).
<p>Verdict criteria</p> <p>If the SaPDU's and the Sa-Primitives conform to the requested pattern => PASS</p>
<p>Test postamble</p> <p>The IUT and the test environment are in the IDLE state.</p>
<p>Comments</p> <p>See Figure 3</p>

Table 3 – Time-out T_{estab}

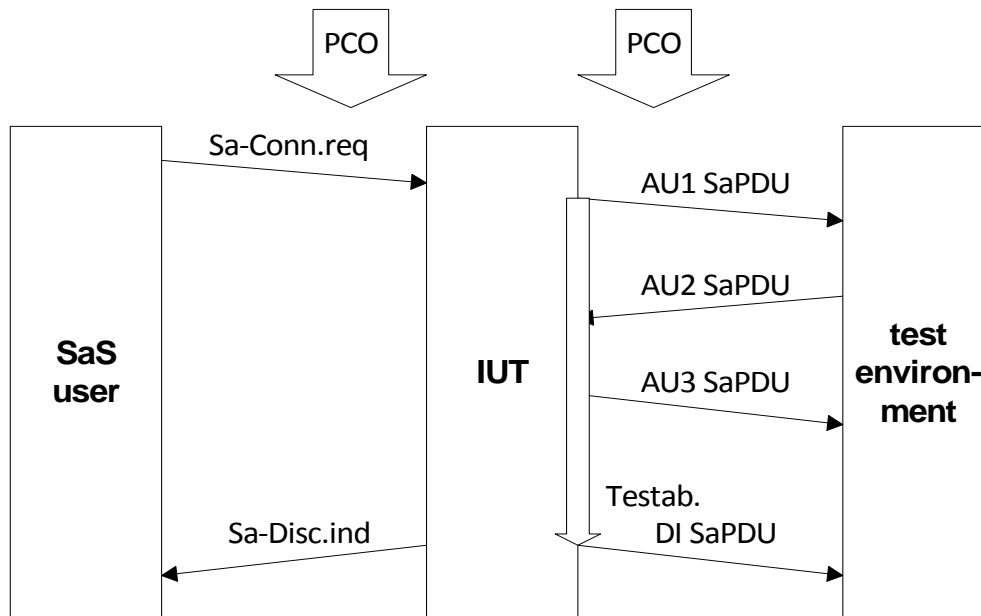

Figure 3 – Time out T_{estab} .

5.2.4 Error case - Time out of Timer T_{estab} after AU1 SaPDU

<p>Header time out of Timer T_{estab}</p> <p>TC No.: 4</p> <p>TC covers the following items of [2]:</p> <p style="padding-left: 40px;">Sa 1, Sa 8, Sa 17, Sa 18, Sa 19, Sa 97, Sa 100, Sa 101B, Sa 103, Sa 104</p> <p style="padding-left: 40px;">Approval of the following items during sending:</p> <p style="padding-left: 80px;">Sa 31B, Sa 32, Sa 33, Sa 34, Sa 35, Sa 36</p>
<p>Test summary</p> <p>To test the time out of $t_{\text{establishment}}$</p>
<p>Test preamble</p> <p>The IUT and the test environment have to be brought into the IDLE state.</p>
<p>Constraints</p> <p>Test environment sends a delayed answer to the T-Conn.req (delay > T_{estab} due to delay of transmission channel or test environment (EURORADIO part)).</p>
<p>Test body</p> <ul style="list-style-type: none"> - The IUT receives a Sa-Conn.req (including called address, calling address, application type, QoS). - The IUT generates a T-Conn.req containing an AU1 SaPDU. - The test environment (EURORADIO part) accepts the request and answers with a T-Conn.resp containing an AU2 SaPDU, but high delayed (reception of AU2 SaPDU after T_{estab}). - After T_{estab} the IUT indicates the time out of T_{estab} by Sa-Disc.ind (without DI SaPDU) and T-Disc.req. - If the AU2 SaPDU is received after issuing the Disconnect request, it has to be ignored.
<p>Verdict criteria</p> <p>If the SaPDU's and the Sa-Primitives conform to the requested pattern => PASS</p>
<p>Test postamble</p> <p>The IUT and the test environment are in the IDLE state.</p>
<p>Comments</p> <p>See Figure 4</p>

Table 4 – Time-out T_{estab}

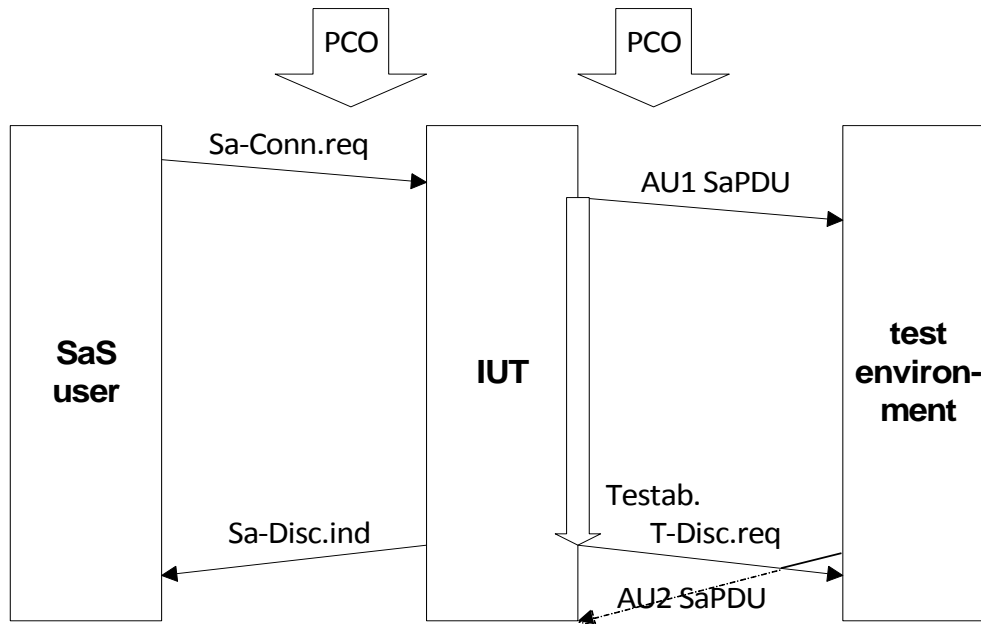

Figure 4 – Time out T_{estab} .

5.2.5 Error case – Connect request with wrong application type

Note: This test case checks the protection against a wrong behaviour of the own SaS user (Sa-Connect.req is received from SaS user with wrong application type). It can be realized according to company specific specifications of the internal interface between SaS user and IUT. The item Sa 77 A of [2] is covered by this company specific test case.

5.2.6 Error case – Reception of an AU2 SaPDU with an unexpected responding ETCS-ID

Header	Connection establishment – outgoing request
TC No.:	5
TC covers the following items of [2]:	
Sa 1, Sa 8, Sa 13, Sa 15, 9, Sa 79, Sa 100, Sa 101B, Sa 104	
Approval of the following items during sending:	
Sa 31B, Sa 32, Sa 33, Sa 34, Sa 35, Sa 36, Sa 57, Sa 58, Sa 59A, Sa 60, Sa61	
Approval of the following items during receiving:	
Sa 38, Sa 40	
Test summary	To test the establishment of a connection with a non-acceptable peer.
Test preamble	The IUT and the test environment have to be brought into the IDLE state.
Constraints	Received Sa-Conn.req during test case execution includes at least application type and called

ETCS-ID "A", "A" is different from unknown (0xFFFFFFFF).

Test body

- The IUT receives a Sa-Conn.req.
- The IUT generates a T-Conn.req containing an AU1 SaPDU.
- The test environment accepts the request and answers with a T-Conn.resp containing an AU2 SaPDU (responding ETCS-ID "B").
- The IUT receives the T-Conn.conf containing this AU2 SaPDU.
- The IUT generates a T-Disc.req without a DI SaPDU and a Sa-Disc.ind with reason 8, subreason 4.

Verdict criteria

If the SaPDU and Sa-Primitives conform to the requested pattern => PASS

Test postamble

The IUT and the test environment are in the IDLE state.

Comments

See Figure 5

Table 5 – Connection establishment (outgoing request) – error case

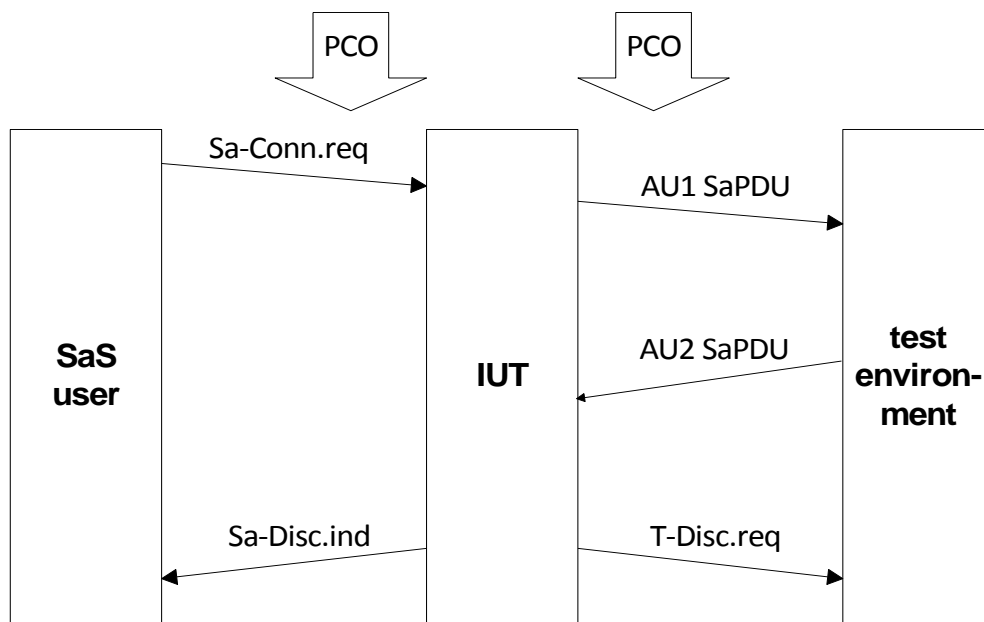

Figure 5 – Reception of unacceptable AU2 SaPDU

5.2.7 Error case – Reception of an AU2 SaPDU with MAC error

Header	Connection establishment – outgoing request
TC No.:	6

<p>TC covers the following items of [2]:</p> <p>Sa 1, Sa 8, Sa 19, Sa 81, Sa 99, Sa 100, Sa 101B, Sa 104</p> <p>Approval of the following items during sending:</p> <p>Sa 31B, Sa 32, Sa 33, Sa 34, Sa 35, Sa 36, Sa 57, Sa 58, Sa 59A, Sa 60, Sa61</p> <p>Approval of the following items during receiving:</p> <p>Sa 37A, Sa 38, Sa 39, Sa 40, Sa 41, Sa 42</p>
<p>Test summary</p> <p>To test the establishment of a connection with an error during peer entity authentication (MAC error of AU2 SaPDU).</p>
<p>Test preamble</p> <p>The IUT and the test environment have to be brought into the IDLE state.</p>
<p>Constraints</p>
<p>Test body</p> <ul style="list-style-type: none"> - The IUT receives an Sa-Conn.req (including at least application type). - The IUT generates a T-Conn.req containing an AU1 SaPDU. - The test environment accepts the request and answers with a T-Conn.resp containing an AU2 SaPDU, but the MAC of this SaPDU is wrong (due to wrong key configuration or simulated by test environment). - The IUT receives the T-Conn.conf containing this AU2 SaPDU. - The IUT generates a T-Disc.req without DI SaPDU and a Sa-Disc.ind with reason 4, subreason 2.
<p>Verdict criteria</p> <p>If the SaPDU and Sa-Primitives conform to the requested pattern => PASS</p>
<p>Test postamble</p> <p>The IUT and the test environment are in the IDLE state.</p>
<p>Comments</p> <p>See Figure 5</p>

Table 6 – Connection establishment (outgoing request) – error case

5.2.8 Error case – Reception of an AR SaPDU with MAC error

Header	Connection establishment – outgoing request
TC No.:	7
TC covers the following items of [2]:	
	Sa 1, Sa 8, Sa 14, Sa 15, Sa 19, Sa 20, Sa 83, Sa 100, Sa 101B, Sa 104
	Approval of the following items during sending:
	Sa 31B, Sa 32, Sa 33, Sa 34, Sa 35, Sa 36, Sa 44, Sa 45, Sa 46, Sa 47, Sa 57, Sa 58, Sa 59A, Sa 60, Sa61
	Approval of the following items during receiving:
	Sa 37A, Sa 38, Sa 39, Sa 40, Sa 41, Sa 42, Sa 43, Sa 48, Sa 49, Sa 50
Test summary	To test the establishment of a connection with an error during establishment of the safe connection (MAC error of AR SaPDU).
Test preamble	The IUT and the test environment have to be brought into the IDLE state.
Constraints	
Test body	<ul style="list-style-type: none"> - The IUT receives a Sa-Conn.req (including at least application type). - The IUT generates a T-Conn.req containing an AU1 SaPDU. - The test environment accepts the request and answers with a T-Conn.resp containing an AU2 SaPDU. - The IUT receives the T-Conn.conf containing this AU2 SaPDU. - The IUT generates a T-Data.req containing an AU3 SaPDU. - The test environment answers with a T-Data.req containing an AR SaPDU, but the MAC of this SaPDU is wrong. - The IUT receives the T-Data.ind containing this AR SaPDU. - The IUT generates a T-Disc.req containing a DI SaPDU and a Sa-Disc.ind, both with reason 4, subreason 4.
Verdict criteria	If the SaPDU and Sa-Primitives conform to the requested pattern => PASS
Test postamble	The IUT and the test environment are in the IDLE state.
Comments	See Figure 6

Table 7 – Connection establishment (outgoing request) – error case

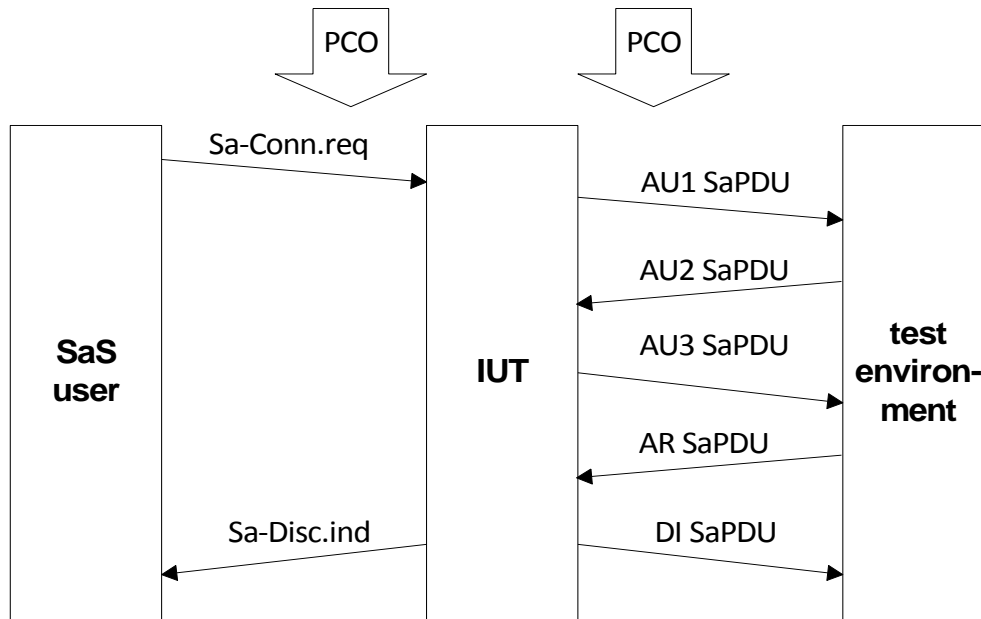

Figure 6 – Reception of an unacceptable AR SaPDU

5.2.9 Error case – Reception of an AU2 SaPDU with wrong direction flag

Header	Connection establishment – outgoing request
TC No.:	8
TC covers the following items of [2]:	Sa 1, Sa 8, Sa 19, Sa 87A, Sa 100, Sa 101B Approval of the following items during sending: Sa 31B, Sa 32, Sa 33, Sa 34, Sa 35, Sa 36, Sa 57, Sa 58, Sa 59A, Sa 60, Sa61 Approval of the following items during receiving: Sa 38
Test summary	To test the establishment of a connection with an error during peer entity authentication (wrong direction flag of AU2 SaPDU).
Test preamble	The IUT and the test environment have to be brought into the IDLE state.
Constraints	
Test body	<ul style="list-style-type: none"> - The IUT receives a Sa-Conn.req (including at least application type). - The IUT generates a T-Conn.req containing an AU1 SaPDU. - The test environment accepts the request and answers with a T-Conn.resp containing an AU2 SaPDU, but the direction flag is wrong (all other fields are correct). - The IUT receives the T-Conn.conf containing this AU2 SaPDU. - The IUT generates a T-Disc.req without DI SaPDU and a Sa-Disc.ind with reason 6,

subreason 1.
Verdict criteria If the SaPDU and Sa-Primitives conform to the requested pattern => PASS
Test postamble The IUT and the test environment are in the IDLE state.
Comments See Figure 5

Table 8 – Connection establishment (outgoing request) – error case

5.2.10 Error case – Reception of an AR SaPDU with wrong direction flag

Header	Connection establishment – outgoing request
TC No.:	9
TC covers the following items of [2]:	
Sa 1, Sa 8, Sa 14, Sa 15, Sa 19, Sa 20, Sa 87C, Sa 100, Sa 101B, Sa 104	
Approval of the following items during sending:	
Sa 31B, Sa 32, Sa 33, Sa 34, Sa 35, Sa 36, Sa 44, Sa 45, Sa 46, Sa 47, Sa 57, Sa 58, Sa 59A, Sa 60, Sa61	
Approval of the following items during receiving:	
Sa 37A, Sa 38, Sa 39, Sa 40, Sa 41, Sa 42, Sa 43, Sa 49, Sa 50	
Test summary	To test the establishment of a connection with an error during establishment of the safe connection (wrong direction flag of the AR SaPDU).
Test preamble	The IUT and the test environment have to be brought into the IDLE state.
Constraints	
Test body	<ul style="list-style-type: none"> - The IUT receives a Sa-Conn.req (including at least application type). - The IUT generates a T-Conn.req containing an AU1 SaPDU. - The test environment accepts the request and answers with a T-Conn.resp containing an AU2 SaPDU. - The IUT receives the T-Conn.conf containing this AU2 SaPDU. - The IUT generates a T-Data.req containing an AU3 SaPDU. - The test environment answers with a T-Data.req containing an AR SaPDU, but the direction flag of this SaPDU is wrong (all other fields are correct). - The IUT receives the T-Data.ind containing this AR SaPDU. - The IUT generates a T-Disc.req containing a DI SaPDU and a Sa-Disc.ind, both with reason 6,

subreason 1.
Verdict criteria If the SaPDU and Sa-Primitives conform to the requested pattern => PASS
Test postamble The IUT and the test environment are in the IDLE state.
Comments See Figure 6

Table 9 – Connection establishment (outgoing request) – error case

5.2.11 Error case – Reception of an AU2 SaPDU with wrong ETY field

Header	Connection establishment – outgoing request
TC No.:	10
TC covers the following items of [2]:	
	Sa 1, Sa 8, Sa 19, Sa 90, Sa 100, Sa 101B
	Approval of the following items during sending:
	Sa 31B, Sa 32, Sa 33, Sa 34, Sa 35, Sa 36, Sa 57, Sa 58, Sa 59A, Sa 60, Sa61
	Approval of the following items during receiving:
	Sa 38
Test summary	To test the establishment of a connection with an error during peer entity authentication (wrong field ETY of AU2 SaPDU).
Test preamble	The IUT and the test environment have to be brought into the IDLE state.
Constraints	
Test body	<ul style="list-style-type: none"> - The IUT receives a Sa-Conn.req (including at least application type). - The IUT generates a T-Conn.req containing an AU1 SaPDU. - The test environment accepts the request and answers with a T-Conn.resp containing an AU2 SaPDU, but the field ETY is wrong (all other fields are correct). - The IUT receives the T-Conn.conf containing this AU2 SaPDU. - The IUT generates a Sa-Disc.ind (reason 9 subreason 1) and a T-Disc.req without a DI SaPDU.
Verdict criteria	If the SaPDU and Sa-Primitives conform to the requested pattern => PASS
Test postamble	The IUT and the test environment are in the IDLE state.

Comments

See Figure 5

Table 10 – Connection establishment (outgoing request) – error case

5.2.12 Intentionally deleted.

5.2.13 Error case – Reception of an AU2 SaPDU with not supported safety feature

Header	Connection establishment – outgoing request
TC No.:	11
TC covers the following items of [2]:	<p>Sa 1, Sa 8, Sa 19, Sa 93, Sa 100, Sa 101B</p> <p>Approval of the following items during sending: Sa 31B, Sa 32, Sa 33, Sa 34, Sa 35, Sa 36, Sa 57, Sa 58, Sa 59A, Sa 60, Sa61</p> <p>Approval of the following items during receiving: Sa 38</p>
Test summary	To test the establishment of a connection with an unsupported safety feature.
Test preamble	The IUT and the test environment have to be brought into the IDLE state.
Constraints	
Test body	<ul style="list-style-type: none"> - The IUT receives a Sa-Conn.req (including at least application type). - The IUT generates a T-Conn.req containing an AU1 SaPDU. - The test environment accepts the request and answers with a T-Conn.resp containing an AU2 SaPDU, but the field safety feature is wrong (different from '0000 0001'). - The IUT receives the T-Conn.conf containing this AU2 SaPDU. - The IUT generates a T-Disc.req without DI SaPDU and a Sa-Disc.ind with reason 3, subreason 29.
Verdict criteria	If the SaPDU and Sa-Primitives conform to the requested pattern => PASS
Test postamble	The IUT and the test environment are in the IDLE state.
Comments	See Figure 5

Table 11 – Connection establishment (outgoing request) – error case

5.2.14 Error case – Sequence error after AU1 SaPDU

Header	Connection establishment – outgoing request
TC No.:	12
TC covers the following items of [2]:	Sa 1, Sa 8, Sa 19, Sa 94C, Sa 100, Sa 101B Approval of the following items during sending: Sa 31B, Sa 32, Sa 33, Sa 34, Sa 35, Sa 36, Sa 57, Sa 58, Sa 59A, Sa 60, Sa61
Test summary	To test the establishment of a connection with a sequence error during peer entity authentication.
Test preamble	The IUT and the test environment have to be brought into the IDLE state.
Constraints	
Test body	<ul style="list-style-type: none"> - The IUT receives a Sa-Conn.req (including at least application type). - The IUT generates a T-Conn.req containing an AU1 SaPDU. - The test environment accepts the request and answers with a T-Conn.resp containing a SaPDU, but the field MTI is different from '0010' (all other fields are correct for AU2 SaPDU). - The IUT receives the T-Conn.conf containing this AU2 SaPDU. - The IUT generates a Sa-Disc.ind (including reason code according to internal commitments) and a T-Disc.req without a DI SaPDU.
Verdict criteria	If the SaPDU and Sa-Primitives conform to the requested pattern => PASS
Test postamble	The IUT and the test environment are in the IDLE state.
Comments	See Figure 5

Table 12 – Connection establishment (outgoing request) – error case

5.2.15 Error case – Transport Connection Confirmation without AU2 SaPDU

Header	Connection establishment – outgoing request
TC No.:	13
TC covers the following items of [2]:	Sa 1, Sa 8, Sa 19, Sa 94D, Sa 100, Sa 101B Approval of the following items during sending: Sa 31B, Sa 32, Sa 33, Sa 34, Sa 35, Sa 36, Sa 57, Sa 58, Sa 59A, Sa 60, Sa61
Test summary	

To test the establishment of a connection with a sequence error during peer entity authentication.

Test preamble

The IUT and the test environment have to be brought into the IDLE state.

Constraints

Test body

- The IUT receives a Sa-Conn.req (including at least application type).
- The IUT generates a T-Conn.req containing an AU1 SaPDU.
- The test environment accepts the request and answers with a T-Conn.conf without user data.
- The IUT receives the T-Conn.conf.
- The IUT generates a Sa-Disc.ind (reason 9 subreason 1) and a T-Disc.req without a DI SaPDU.

Verdict criteria

If the SaPDU and Sa-Primitives conform to the requested pattern => PASS

Test postamble

The IUT and the test environment are in the IDLE state.

Comments

See Figure 7

Table 13 – Connection establishment (outgoing request) – error case

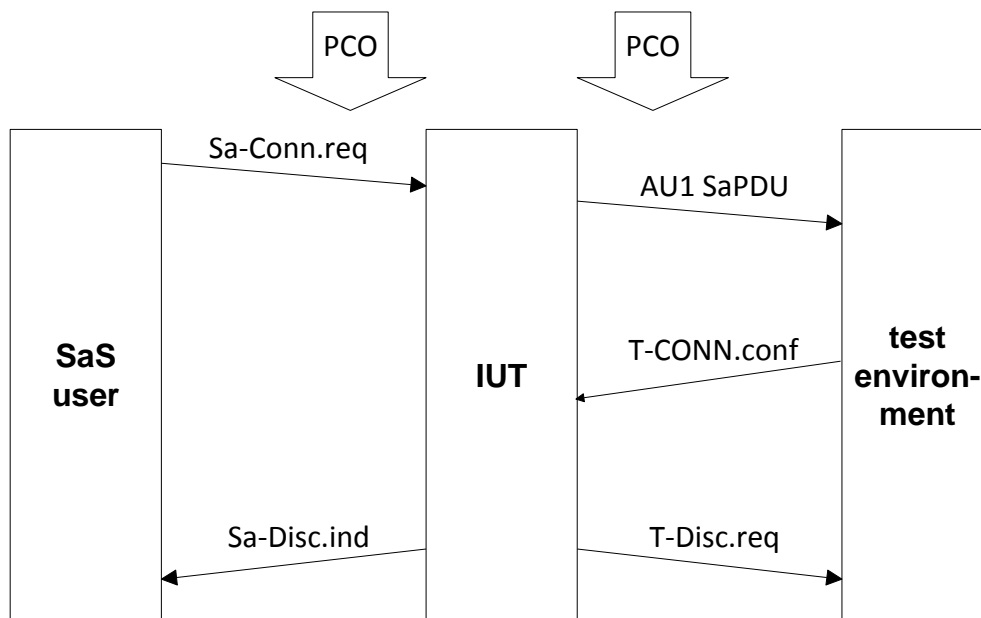

Figure 7 – T-Conn.conf without user data

5.2.16 Error case – Sequence error after AU3 SaPDU

Header	Connection establishment – outgoing request
TC No.:	14
TC covers the following items of [2]:	<p>Sa 1, Sa 8, Sa 14, Sa 15, Sa 19, Sa 20, Sa 94F, Sa 100, Sa 101B, Sa 104</p> <p>Approval of the following items during sending:</p> <p style="padding-left: 40px;">Sa 31B, Sa 32, Sa 33, Sa 34, Sa 35, Sa 36, Sa 44, Sa 45, Sa 46, Sa 47, Sa 57, Sa 58, Sa 59A, Sa 60, Sa61</p> <p>Approval of the following items during receiving:</p> <p style="padding-left: 40px;">Sa 37A, Sa 38, Sa 39, Sa 40, Sa 41, Sa 42, Sa 43</p>
Test summary	To test the establishment of a connection with a sequence error during peer entity authentication.
Test preamble	The IUT and the test environment have to be brought into the IDLE state.
Constraints	
Test body	<ul style="list-style-type: none"> - The IUT receives a Sa-Conn.req (including at least application type). - The IUT generates a T-Conn.req containing an AU1 SaPDU. - The test environment accepts the request and answers with a T-Conn.resp containing an AU2 SaPDU. - The IUT receives the T-Conn.conf containing this AU2 SaPDU. - The IUT generates a T-Data.req containing an AU3 SaPDU. - The test environment answer with a T-Data.req containing an AR SaPDU, but the field MTI is different from '1001' (all other fields are correct for AR SaPDU). - The IUT receives the T-Data.ind containing this AR SaPDU. - The IUT generates a T-Disc.req containing a DI SaPDU and a Sa-Disc.ind, both with reason 9, subreason 3.
Verdict criteria	If the SaPDU and Sa-Primitives conform to the requested pattern => PASS
Test postamble	The IUT and the test environment are in the IDLE state.
Comments	See Figure 6

Table 14 – Connection establishment (outgoing request) – error case

5.2.17 Error case – Reception of an AU2 SaPDU with wrong length

<p>Header Connection establishment – outgoing request</p> <p>TC No.: 15</p> <p>TC covers the following items of [2]:</p> <p style="padding-left: 40px;">Sa 1, Sa 8, Sa 19, Sa 95B, Sa 96B, Sa 100, Sa 101B</p> <p style="padding-left: 40px;">Approval of the following items during sending:</p> <p style="padding-left: 80px;">Sa 31B, Sa 32, Sa 33, Sa 34, Sa 35, Sa 36, Sa 57, Sa 58, Sa 59A, Sa 60, Sa61</p> <p style="padding-left: 40px;">Approval of the following items during receiving:</p> <p style="padding-left: 80px;">Sa 38</p>
<p>Test summary</p> <p>To test the establishment of a connection with an error during peer entity authentication (AU2 SaPDU is received with an wrong length)</p>
<p>Test preamble</p> <p>The IUT and the test environment have to be brought into the IDLE state.</p>
<p>Constraints</p>
<p>Test body</p> <ul style="list-style-type: none"> - The IUT receives a Sa-Conn.req (including at least application type). - The IUT generates a T-Conn.req containing an AU1 SaPDU. - The test environment accepts the request and answers with a T-Conn.resp containing a AU2 SaPDU, but the is length of the AU2 SaPDU is <ul style="list-style-type: none"> a) Too short. b) Too long. - The IUT receives the T-Conn.conf containing this AU2 SaPDU. - The IUT generates a Sa-Disc.ind (reason 10 subreason 2) and a T-Disc.req without a DI SaPDU.
<p>Verdict criteria</p> <p>If the SaPDU and Sa-Primitives conform to the requested pattern => PASS</p>
<p>Test postamble</p> <p>The IUT and the test environment are in the IDLE state.</p>
<p>Comments</p> <p>The test cases must be executed twice (once for case a and once for case b).</p> <p>See Figure 5</p>

Table 15 – Connection establishment (outgoing request) – error case

5.2.18 Error case – Reception of an AR SaPDU with wrong length

<p>Header</p> <p>TC No.: 16</p> <p>TC covers the following items of [2]:</p> <p style="padding-left: 40px;">Sa 1, Sa 8, Sa 14, Sa 15, Sa 19, Sa 20, Sa 95D, Sa96D, Sa 100, Sa 101B, Sa 104</p> <p style="padding-left: 40px;">Approval of the following items during sending:</p> <p style="padding-left: 80px;">Sa 31B, Sa 32, Sa 33, Sa 34, Sa 35, Sa 36, Sa 44, Sa 45, Sa 46, Sa 47, Sa 57, Sa 58, Sa 59A, Sa 60, Sa61</p> <p style="padding-left: 40px;">Approval of the following items during receiving:</p> <p style="padding-left: 80px;">Sa 37A, Sa 38, Sa 39, Sa 40, Sa 41, Sa 42, Sa 43, Sa 49</p>	<p>Connection establishment – outgoing request</p>
<p>Test summary</p> <p>To test the establishment of a connection with an error during peer entity authentication (AR SaPDU is received with the wrong length)</p>	
<p>Test preamble</p> <p>The IUT and the test environment have to be brought into the IDLE state.</p>	
<p>Constraints</p>	
<p>Test body</p> <ul style="list-style-type: none"> - The IUT receives a Sa-Conn.req (including at least application type). - The IUT generates a T-Conn.req containing an AU1 SaPDU. - The test environment accepts the request and answers with a T-Conn.resp containing an AU2 SaPDU. - The IUT receives the T-Conn.conf containing this AU2 SaPDU. - The IUT generates a T-Data.req containing an AU3 SaPDU. - The test environment accepts the request and answers with a T-Data.req containing a AR SaPDU, but the is length of the AR SaPDU is <ul style="list-style-type: none"> a) Too short. b) Too long. - The IUT receives the T-Data.ind containing this AR SaPDU. - The IUT generates a T-Disc.req containing a DI SaPDU and a Sa-Disc.ind, both with reason 10, subreason 8. 	
<p>Verdict criteria</p> <p>If the SaPDU and Sa-Primitives conform to the requested pattern => PASS</p>	
<p>Test postamble</p> <p>The IUT and the test environment are in the IDLE state.</p>	
<p>Comments</p> <p>The test cases must be executed twice (once for case a and once for case b).</p>	

See Figure 6

Table 16 – Connection establishment (outgoing request) – error case

5.2.19 Error case – Revocation of a connect request during peer entity authentication

Header			
Connection establishment – outgoing request			
TC No.: 17			
TC covers the following items of [2]:			
Sa 1, Sa 7, Sa 19, Sa 100, Sa 101B			
Approval of the following items during sending:			
Sa 31B, Sa 32, Sa 33, Sa 34, Sa 35, Sa 36, Sa 57, Sa 58, Sa 59A, Sa 60, Sa61			
Test summary			
To test the establishment of a connection, but during the execution of the peer entity authentication the SaS user revokes the request by a Sa-Disconnect.request			
Test preamble			
The IUT and the test environment have to be brought into the IDLE state.			
Constraints			
Test body			
<ul style="list-style-type: none"> - The IUT receives a Sa-Conn.req (including at least application type). - The IUT generates a T-Conn.req containing an AU1 SaPDU. - Due to independent sequence of the events on the both interfaces the test body can be one of the following: <table border="1" data-bbox="159 1299 1474 1926"> <tr> <td style="width: 50%; vertical-align: top;"> <ul style="list-style-type: none"> - The IUT receives a Sa-Disc.req (before an AU3 SaPDU is issued). - The IUT generates a T-Disc.req containing a DI SaPDU with reason 0, subreason according to the received subreason of the Sa-Disc.req. - In this case the IUT ignores a received T-Conn.conf (containing an AU2 SaPDU), if any. </td> <td style="width: 50%; vertical-align: top;"> <ul style="list-style-type: none"> - The test environment accepts the request and answer with a T-Conn.resp containing an AU2 SaPDU. - The IUT receives the T-Conn.conf containing this AU2 SaPDU. - The IUT generates a T-Data.req containing an AU3 SaPDU. - The IUT receives a Sa-Disc.req. - The IUT generates a T-Disc.req containing a DI SaPDU with reason 0, subreason according to the received subreason of the Sa-Disc.req. - In this case the IUT ignores a received T-Data.ind (containing an AR SaPDU), if any. </td> </tr> </table> 		<ul style="list-style-type: none"> - The IUT receives a Sa-Disc.req (before an AU3 SaPDU is issued). - The IUT generates a T-Disc.req containing a DI SaPDU with reason 0, subreason according to the received subreason of the Sa-Disc.req. - In this case the IUT ignores a received T-Conn.conf (containing an AU2 SaPDU), if any. 	<ul style="list-style-type: none"> - The test environment accepts the request and answer with a T-Conn.resp containing an AU2 SaPDU. - The IUT receives the T-Conn.conf containing this AU2 SaPDU. - The IUT generates a T-Data.req containing an AU3 SaPDU. - The IUT receives a Sa-Disc.req. - The IUT generates a T-Disc.req containing a DI SaPDU with reason 0, subreason according to the received subreason of the Sa-Disc.req. - In this case the IUT ignores a received T-Data.ind (containing an AR SaPDU), if any.
<ul style="list-style-type: none"> - The IUT receives a Sa-Disc.req (before an AU3 SaPDU is issued). - The IUT generates a T-Disc.req containing a DI SaPDU with reason 0, subreason according to the received subreason of the Sa-Disc.req. - In this case the IUT ignores a received T-Conn.conf (containing an AU2 SaPDU), if any. 	<ul style="list-style-type: none"> - The test environment accepts the request and answer with a T-Conn.resp containing an AU2 SaPDU. - The IUT receives the T-Conn.conf containing this AU2 SaPDU. - The IUT generates a T-Data.req containing an AU3 SaPDU. - The IUT receives a Sa-Disc.req. - The IUT generates a T-Disc.req containing a DI SaPDU with reason 0, subreason according to the received subreason of the Sa-Disc.req. - In this case the IUT ignores a received T-Data.ind (containing an AR SaPDU), if any. 		
Verdict criteria			
If the SaPDU and Sa-Primitives conform to the requested pattern => PASS			

Test postamble

The IUT and the test environment are in the IDLE state.

Comments

See Figure 8 and Figure 9

Table 17 – Connection establishment (outgoing request) – revocation of connect request

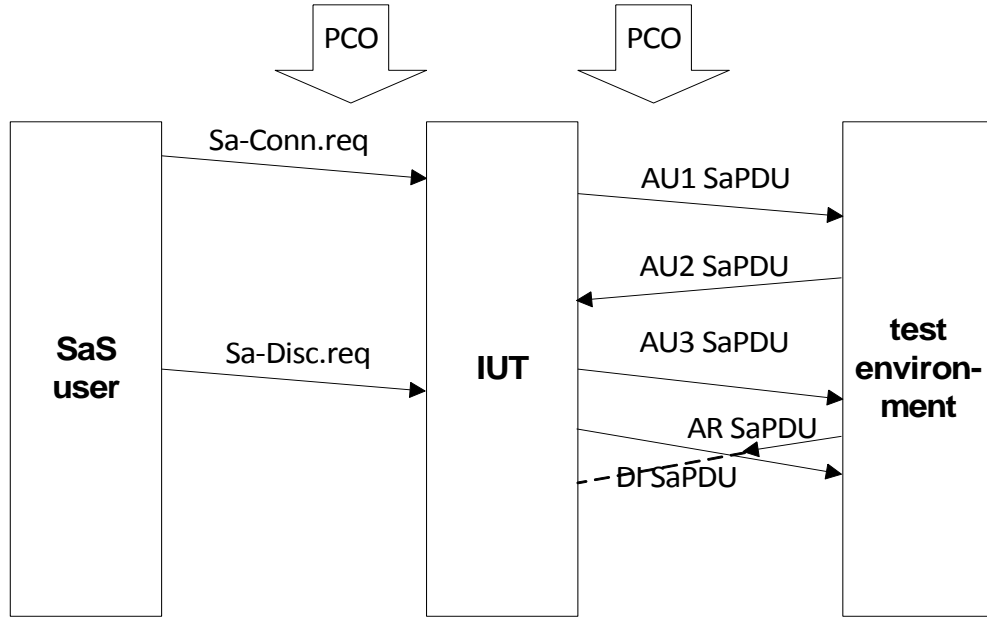

Figure 8 – Revocation during safe connection establishment

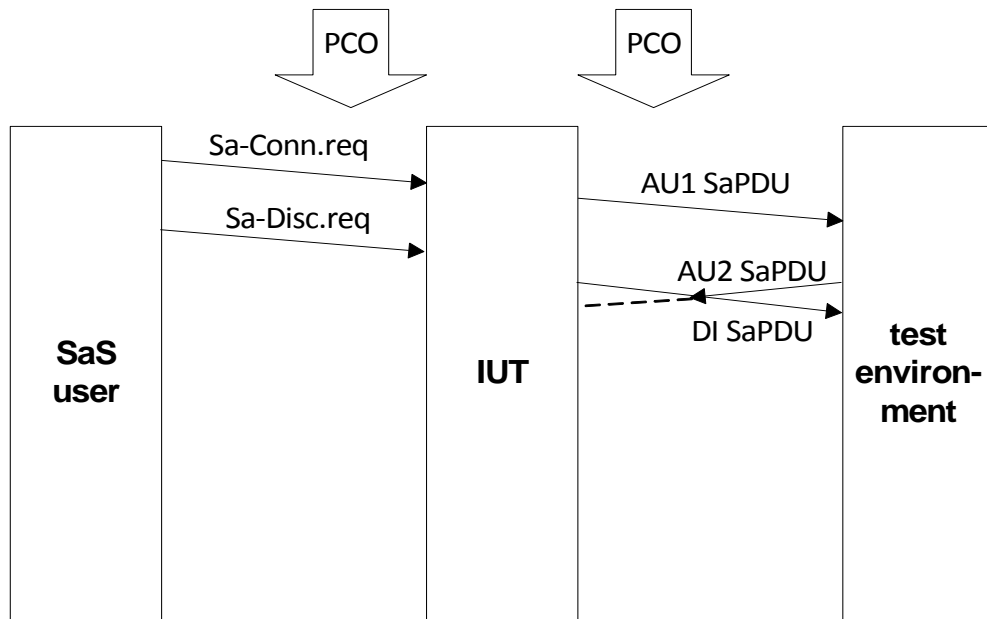

Figure 9 – Revocation during safe connection establishment

5.2.20 Error case – No transport connection available

Header	Connection establishment – outgoing request
TC No.:	18
TC covers the following items of [2]:	Sa 1, Sa 8, Sa 19, Sa 80, Sa 100, Sa 101B Approval of the following items during sending: Sa 31B, Sa 32, Sa 33, Sa 34, Sa 35, Sa 36
Test summary	To test the establishment of a connection with a sequence error during peer entity authentication.
Test preamble	The IUT has to be brought into the IDLE state, connection to test equipment is not available (e.g. test equipment switched off, connection broken, wrong configuration of network address).
Constraints	
Test body	<ul style="list-style-type: none"> - The IUT receives a Sa-Conn.req (including at least application type). - The IUT generates a T-Conn.req containing an AU1 SaPDU. - Connection to test environment is not available, therefore a T-Disc.ind with a certain reason is indicated. - The IUT generates a Sa-Disc.ind (reason 1).
Verdict criteria	If the SaPDU and Sa-Primitives conform to the requested pattern => PASS
Test postamble	The IUT and the test environment are in the IDLE state.
Comments	See Figure 10

Table 18 – Connection establishment (outgoing request) – error case

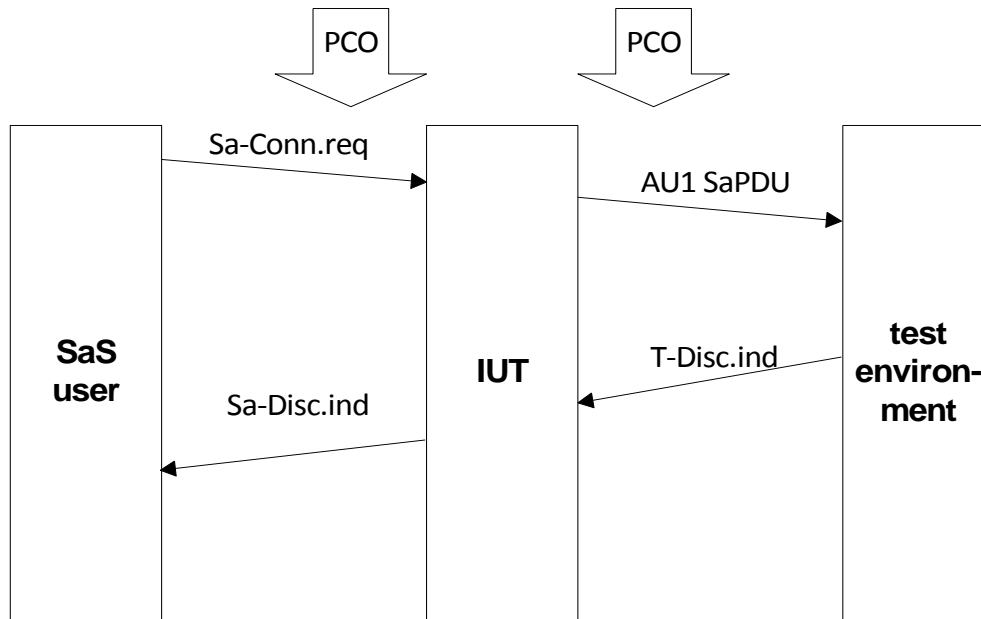

Figure 10 – No transport connection available

5.3 Connection establishment (incoming request)

5.3.1 Normal order of events

Header	Connection establishment – incoming request
TC No.:	19
TC covers the following items of [2]:	Sa 2, Sa 3, Sa 12, Sa 13, Sa 14, Sa 15, Sa 16, Sa 22, Sa 23, Sa 24, Sa 100, Sa 101A, Sa 102, Sa 104
Approval of the following items during sending:	Sa 37A, Sa 37B, Sa 38, Sa 39, Sa 40, Sa 41, Sa 42, Sa 43, Sa 48, Sa 49, Sa 50, Sa 51
Approval of the following items during receiving:	Sa 31B, Sa 31 A, Sa 32, Sa 33, Sa 34, Sa 35, Sa 36, Sa 44, Sa 45, Sa 46, Sa 47
Test summary	To test the establishment of a connection (incoming connection request). The test cases have to be executed for each possible direction .
Test preamble	The IUT and the test environment have to be brought into the IDLE state.
Constraints	Keys according to used ETCS-ID's are available.
Test body	

- The IUT receives a T-Conn.ind (including AU1 SaPDU) from test environment.
- The IUT generates a T-Conn.resp containing an AU2 SaPDU.
- The test environment accepts the response and answers with a T-Data.req containing an AU3 SaPDU.
- The IUT receives the T-Data.ind containing this AU3 SaPDU.
- Connection establishment is indicated to the SaS user by Sa-Conn.ind primitive.
- SaS user accepts the connection using a Sa-Conn.resp.
- The IUT generates a T-Data.req containing an AR SaPDU.

Verdict criteria

If the SaPDU's and the Sa-Primitives conform to the requested pattern => PASS

Test postamble

The IUT and the test environment are in the DATA state.

Comments

See Figure 11

If the IUT should not be used as component of an RBC as well as a component of an on-board unit, a single execution of the test case with the corresponding test data is sufficient.

Table 19 – Connection establishment (incoming request)

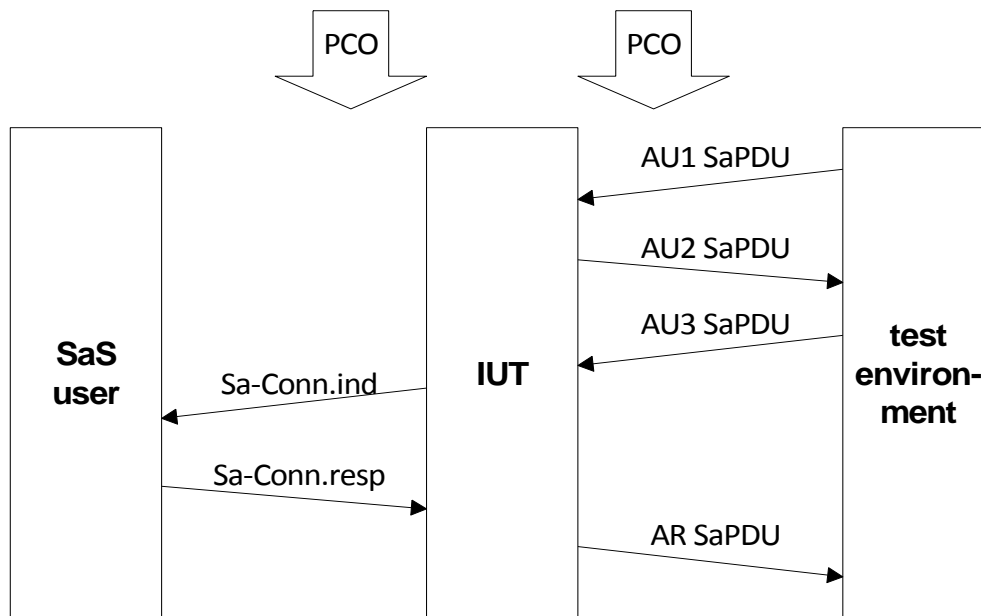

Figure 11 – Normal order of events (incoming connect request)

5.3.2 Error case - Missing authentication key

Header	Connection establishment – incoming request – error case
TC No.:	20
TC covers the following items of [2]:	<p>Sa 78</p> <p>Approval of the following items during sending: Sa 57, Sa 58, Sa 59B, Sa 60, Sa 61</p> <p>Approval of the following items during receiving: Sa 31B, Sa 32, Sa 34</p>
Test summary	To test the establishment of a connection
Test preamble	The IUT and the test environment have to be brought into the IDLE state.
Constraints	Authentication key according to used calling ETCS-ID not available inside IUT.
Test body	<ul style="list-style-type: none"> - The IUT receives a T-Conn.ind (including AU1 SaPDU with ETY = '010'). - The IUT generates a T-Disc.req including a DI SaPDU with reason 3 subreason 2.
Verdict criteria	If the SaPDU's conform to the requested pattern => PASS
Test postamble	The IUT and the test environment are in the IDLE state.
Comments	See Figure 12

Table 20 – Connection establishment (incoming request – error case)

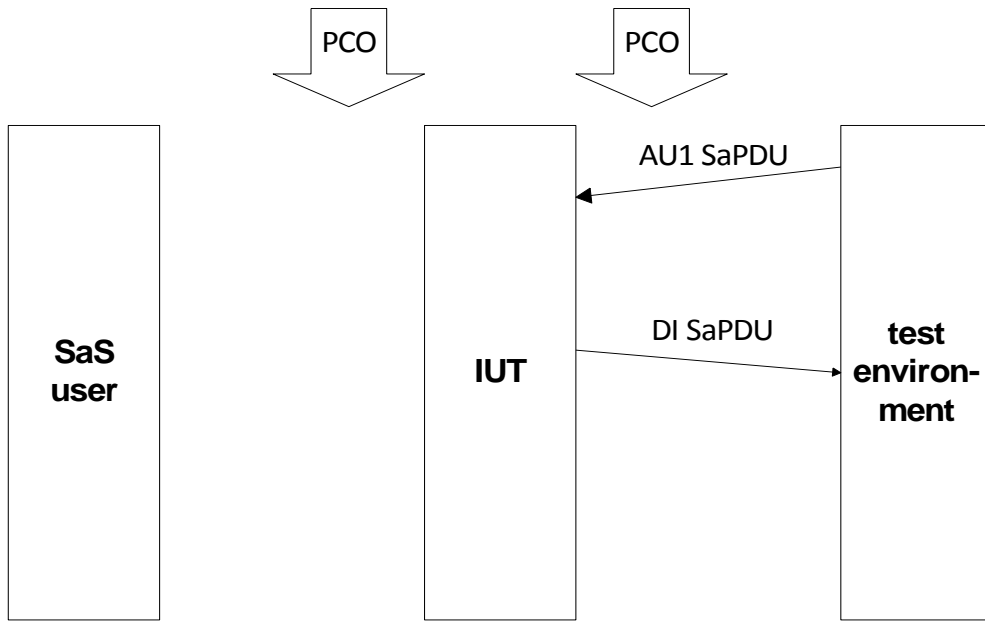

Figure 12 – Reception of an unacceptable AU1 SaPDU

5.3.3 Error case – Reception of an AU3 SaPDU with MAC error

Header	Connection establishment – incoming request
TC No.:	21
TC covers the following items of [2]:	
	Sa 12, Sa 13, Sa 14, Sa 15, Sa 16, Sa 22, Sa 82, Sa 100, Sa 101A, Sa 102, Sa 104
	Approval of the following items during sending:
	Sa 37A, Sa 38, Sa 39, Sa 40, Sa 41, Sa 42, Sa 43, Sa 57, Sa 58, Sa 59B, Sa 60, Sa 61
	Approval of the following items during receiving:
	Sa 31 A, Sa 32, Sa 33, Sa 34, Sa 35, Sa 36, Sa 44, Sa 45, Sa 46, Sa 47
Test summary	To test the establishment of a connection with an error during peer entity authentication.
Test preamble	The IUT and the test environment have to be brought into the IDLE state.
Constraints	Keys according to used ETCS-ID's are available.
Test body	<ul style="list-style-type: none"> - The IUT receives a T-Conn.ind (including AU1 SaPDU). - The IUT generates a T-Conn.resp containing an AU2 SaPDU. - The test environment accepts the response and answers with a T-Data.req containing an AU3 SaPDU, but the MAC of this SaPDU is wrong. - The IUT receives the T-Data.ind containing this AU3 SaPDU. - The IUT generates a T-Disc.req containing a DI SaPDU with reason 4, subreason 3.
Verdict criteria	If the SaPDU's and the Sa-Primitives conform to the requested pattern => PASS
Test postamble	The IUT and the test environment are in the IDLE state.
Comments	see Figure 13

Table 21 – Connection establishment (incoming request) – error case

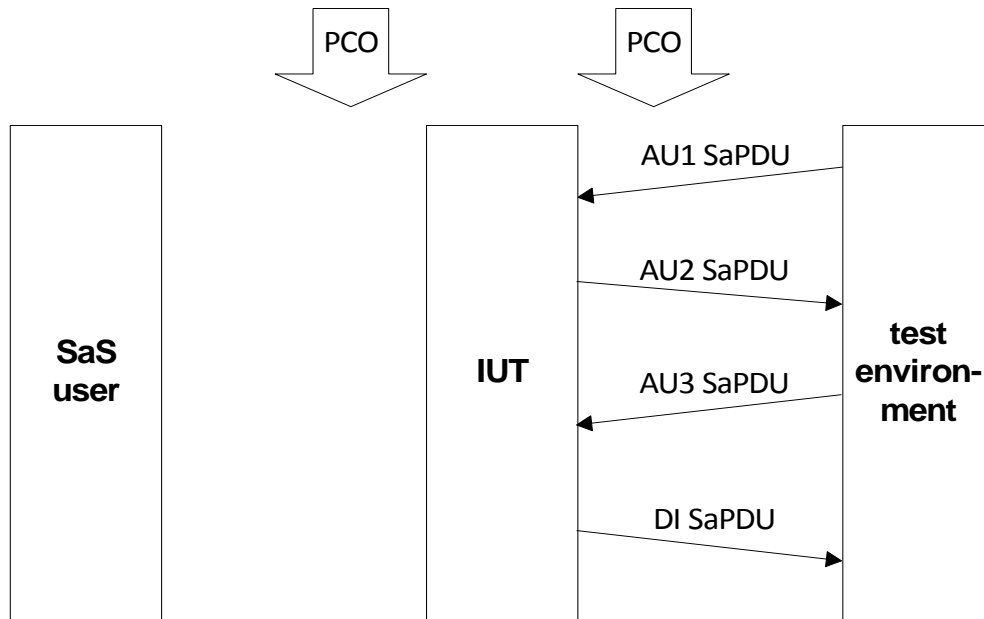

Figure 13 – Reception of an unacceptable AU3 SaPDU

5.3.4 Error case – Reception of an AU1 SaPDU with wrong direction flag

Header	Connection establishment – incoming request
TC No.:	22
TC covers the following items of [2]:	Sa 85
Approval of the following items during receiving:	Sa 32
Test summary	To test the establishment of a connection with an error during peer entity authentication.
Test preamble	The IUT and the test environment have to be brought into the IDLE state.
Constraints	Keys according to used ETCS-ID's are available.
Test body	<ul style="list-style-type: none"> - The IUT receives a T-Conn.ind including AU1 SaPDU, but the direction flag of this AU1 SaPDU is wrong. - The IUT generates a T-Disc.req containing a DI SaPDU with reason 6, subreason 2.
Verdict criteria	If the SaPDU's and the Sa-Primitives conform to the requested pattern => PASS
Test postamble	The IUT and the test environment are in the IDLE state.

Comments

See Figure 12

Table 22 – Connection establishment (incoming request) – error case

5.3.5 Error case – Reception of an AU3 SaPDU with wrong direction flag

Header	Connection establishment – incoming request
TC No.:	23
TC covers the following items of [2]:	<p>Sa 12, Sa 13, Sa 14, Sa 15, Sa 16, Sa 22, Sa 87B, Sa 100, Sa 101A, Sa 102, Sa 104</p> <p>Approval of the following items during sending:</p> <p>Sa 37A, Sa 38, Sa 39, Sa 40, Sa 41, Sa 42, Sa 43, Sa 57, Sa 58, Sa 59B, Sa 60, Sa 61</p> <p>Approval of the following items during receiving:</p> <p>Sa 31B, Sa 32, Sa 33, Sa 34, Sa 35, Sa 36, Sa 45</p>
Test summary	To test the establishment of a connection with an error during peer entity authentication.
Test preamble	The IUT and the test environment have to be brought into the IDLE state.
Constraints	Keys according to used ETCS-ID's are available.
Test body	<ul style="list-style-type: none"> - The IUT receives a T-Conn.ind (including AU1 SaPDU). - The IUT generates a T-Conn.resp containing an AU2 SaPDU. - The test environment accepts the response and answers with a T-Data.req containing an AU3 SaPDU, but the direction flag of this SaPDU is wrong (all other fields are correct). - The IUT receives the T-Data.ind containing this AU3 SaPDU. - The IUT generates a T-Disc.req containing a DI SaPDU with reason 6, subreason 2.
Verdict criteria	If the SaPDU's conform to the requested pattern and no Sa-Primitives are indicated to the SaS user => PASS
Test postamble	The IUT and the test environment are in the IDLE state.
Comments	See Figure 13

Table 23 – Connection establishment (incoming request) – error case

5.3.6 Error case – Reception of an AU1 SaPDU with wrong field ETY

Header	Connection establishment – incoming request
TC No.:	24
TC covers the following items of [2]:	Sa 89, Sa 77 B Approval of the following items during receiving: Sa 32
Test summary	To test the establishment of a connection with an error during peer entity authentication.
Test preamble	The IUT and the test environment have to be brought into the IDLE state.
Constraints	Keys according to used ETCS-ID's are available.
Test body	<ul style="list-style-type: none"> - The IUT receives a T-Conn.ind including AU1 SaPDU, but the field ETY of this AU1 SaPDU is wrong. - The IUT generates a T-Disc.req containing a DI SaPDU with reason 8, subreason 5.
Verdict criteria	If the SaPDU's conform to the requested pattern and no Sa-Primitives are indicated to the SaS user => PASS
Test postamble	The IUT and the test environment are in the IDLE state.
Comments	See Figure 12 Disconnect is requested according to the state table of [1] section 7.2.5.3.7. (ETY error), therefore rejection of the AU1 SaPDU according to the error handling action of this reason code is not sufficient.

Table 24 – Connection establishment (incoming request) – error case

5.3.7 Error case – Reception of AU3 SaPDU with changed first octet

5.3.7.1 Intentionally deleted

5.3.8 Error case – Reception of an AU1 SaPDU with not supported safety feature

Header	Connection establishment – incoming request
TC No.:	25
TC covers the following items of [2]:	Sa 92

Approval of the following items during receiving: Sa 32
Test summary To test the establishment of a connection with an not supported safety feature
Test preamble The IUT and the test environment have to be brought into the IDLE state.
Constraints Keys according to used ETCS-ID's are available.
Test body <ul style="list-style-type: none"> - The IUT receives a T-Conn.ind including AU1 SaPDU, but the field safety feature of this AU1 SaPDU is wrong (different from '0000 0001'). - The IUT generates a T-Disc.req containing a DI SaPDU with reason 3, subreason 29.
Verdict criteria If the SaPDU conform to the requested pattern => PASS
Test postamble The IUT and the test environment are in the IDLE state.
Comments See Figure 12

Table 25 – Connection establishment (incoming request) – error case

5.3.9 Intentionally deleted

5.3.10 Error case – Sequence error during peer entity authentication (reception of first message)

Header Wrong sequence of messages – incoming request
TC No.: 26 TC covers the following items of [2]: Sa 94A
Test summary To test the establishment of a connection with a wrong sequence of messages during peer entity authentication.
Test preamble The IUT and the test environment have to be brought into the IDLE state.
Constraints Keys according to used ETCS-ID's are available.
Test body

<ul style="list-style-type: none"> - The IUT receives a T-Conn.ind including AU1 SaPDU, but the field MTI of this AU1 SaPDU is different to '0001'. - The IUT generates a T-Disc.req containing a DI SaPDU with reason 8, subreason 1.
<p>Verdict criteria</p> <p>If the SaPDU's conform to the requested pattern and no Sa-Primitives are indicated to the SaS user => PASS</p>
<p>Test postamble</p> <p>The IUT and the test environment are in the IDLE state.</p>
<p>Comments</p> <p>See Figure 12 Disconnect is requested according to the state table of [1] section 7.2.5.3.7. (ETY error), therefore rejection of the AU1 SaPDU according to the error handling action of this reason code is not sufficient.</p>

Table 26 – Connection establishment (incoming request) – error case – wrong sequence

5.3.11 Error case - Error during peer entity authentication (first message missing)

<p>Header Wrong sequence of messages – incoming request</p> <p>TC No.: 27</p> <p>TC covers the following items of [2]: Sa 94B</p>
<p>Test summary</p> <p>To test the establishment of a connection with a wrong sequence of messages during peer entity authentication.</p>
<p>Test preamble</p> <p>The IUT and the test environment have to be brought into the IDLE state.</p>
<p>Constraints</p> <p>Keys according to used ETCS-ID's are available.</p>
<p>Test body</p> <ul style="list-style-type: none"> - The IUT receives a T-Conn.ind without any user data. - The IUT generates a T-Disc.req containing a DI SaPDU with reason 10, subreason 1.
<p>Verdict criteria</p> <p>If the SaPDU's conform to the requested pattern and no Sa-Primitives are indicated to the SaS user => PASS</p>
<p>Test postamble</p> <p>The IUT and the test environment are in the IDLE state.</p>
<p>Comments</p> <p>See Figure 14</p>

Table 27 – Connection establishment (incoming request) – error case – wrong sequence

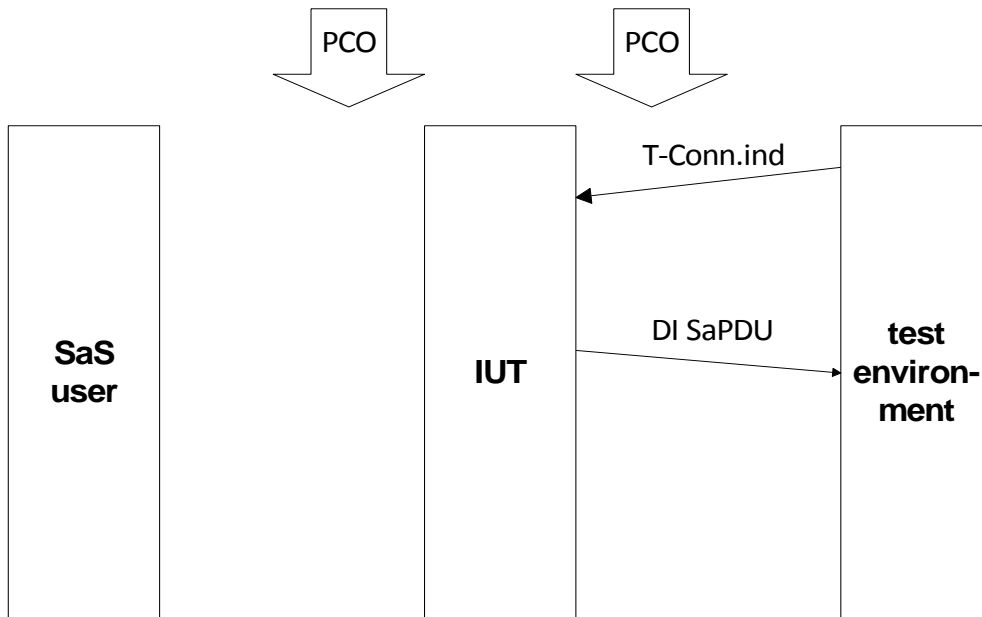

Figure 14 – Reception of an unacceptable T-conn.ind

5.3.12 Error case - Sequence error during peer entity authentication (reception of third message)

Header	Connection establishment – incoming request
TC No.:	28
TC covers the following items of [2]:	Sa 12, Sa 13, Sa 14, Sa 15, Sa 16, Sa 22, Sa 94E, Sa 100, Sa 101A, Sa 102, Sa 104
Approval of the following items during sending:	Sa 37A, Sa 38, Sa 39, Sa 40, Sa 41, Sa 42, Sa 43, Sa 57, Sa 58, Sa 59B, Sa 60, Sa 61
Approval of the following items during receiving:	Sa 31B, Sa 32, Sa 33, Sa 34, Sa 35, Sa 36
Test summary	To test the establishment of a connection with a sequence error during peer entity authentication.
Test preamble	The IUT and the test environment have to be brought into the IDLE state.
Constraints	Keys according to used ETCS-ID's are available.
Test body	<ul style="list-style-type: none"> - The IUT receives a T-Conn.ind (including AU1 SaPDU). - The IUT generates a T-Conn.resp containing an AU2 SaPDU. - The test environment accepts the response and answers with a T-Data.req containing a

<p>SaPDU, but the field MTI is different from '0011' (all other fields are correct for AU3 SaPDU).</p> <ul style="list-style-type: none"> - The IUT receives the T-Data.ind containing this AU3 SaPDU. - The IUT generates a T-Disc.req containing a DI SaPDU with reason 9, subreason 2.
<p>Verdict criteria</p> <p>If the SaPDU's conform to the requested pattern and no Sa-Primitives are indicated to the SaS user => PASS</p>
<p>Test postamble</p> <p>The IUT and the test environment are in the IDLE state.</p>
<p>Comments</p> <p>See Figure 13</p>

Table 28 – Connection establishment (incoming request) – error case

5.3.13 Error case – Reception of an AU1 SaPDU with wrong length

<p>Header Wrong sequence of messages – incoming request</p> <p>TC No.: 29</p> <p>TC covers the following items of [2]:</p> <ul style="list-style-type: none"> Sa 95A, Sa 96A Approval of the following items during receiving: <ul style="list-style-type: none"> Sa 32
<p>Test summary</p> <p>To test the establishment of a connection with a wrong message AU1 SaPDU during peer entity authentication.</p>
<p>Test preamble</p> <p>The IUT and the test environment have to be brought into the IDLE state.</p>
<p>Constraints</p> <p>Keys according to used ETCS-ID's are available.</p>
<p>Test body</p> <ul style="list-style-type: none"> - The IUT receives a T-Conn.ind including AU1 SaPDU, but the is length of the AU1 SaPDU is <ul style="list-style-type: none"> a) Too short. b) Too long. - The IUT generates a T-Disc.req containing a DI SaPDU with reason 10, subreason 1.
<p>Verdict criteria</p> <p>If the SaPDU's conform to the requested pattern and no Sa-Primitives are indicated to the SaS user=> PASS</p>
<p>Test postamble</p>

The IUT and the test environment are in the IDLE state.

Comments

The test cases must be executed twice (once for case a and once for case b).
See Figure 12

Table 29 – Connection establishment (incoming request) – error case – wrong sequence

5.3.14 Error case – Reception of an AU3 SaPDU with wrong length

Header	Connection establishment – incoming request
TC No.:	30
TC covers the following items of [2]:	
	Sa 12, Sa 13, Sa 14, Sa 15, Sa 16, Sa 22, Sa 95C, Sa 96C, Sa 100, Sa 101A, Sa 102, Sa 104
	Approval of the following items during sending:
	Sa 37A, Sa 38, Sa 39, Sa 40, Sa 41, Sa 42, Sa 43, Sa 57, Sa 58, Sa 59B, Sa 60, Sa 61
	Approval of the following items during receiving:
	Sa 31B, Sa 32, Sa 33, Sa 34, Sa 35, Sa 36, Sa 45
Test summary	To test the establishment of a connection with a wrong message AU3 SaPDU during peer entity authentication.
Test preamble	The IUT and the test environment have to be brought into the IDLE state.
Constraints	Keys according to used ETCS-ID's are available.
Test body	<ul style="list-style-type: none"> - The IUT receives a T-Conn.ind (including AU1 SaPDU). - The IUT generates a T-Conn.resp containing an AU2 SaPDU. - The test environment accepts the response and answers with a T-Data.req containing a SaPDU, but the length of the AU3 SaPDU is <ul style="list-style-type: none"> a) Too short. b) Too long. - The IUT receives the T-Data.ind containing this AU3 SaPDU. - The IUT generates a T-Disc.req containing a DI SaPDU with reason 10, subreason 3.
Verdict criteria	If the SaPDU's conform to the requested pattern and no Sa-Primitives are indicated to the SaS user => PASS
Test postamble	

The IUT and the test environment are in the IDLE state.

Comments

The test cases must be executed twice (once for case a and once for case b).
See Figure 13

Table 30 – Connection establishment (incoming request) – error case – wrong length of AU3 SaPDU

5.3.15 Error case – Incoming connect indication is not confirmed by SaS user

Header	Connection establishment – incoming request
TC No.:	31
TC covers the following items of [2]:	
	Sa 2, Sa 7, Sa 12, Sa 13, Sa 14, Sa 15, Sa 16, Sa 22, Sa 23, Sa 100, Sa 101A, Sa 102, Sa 104
	Approval of the following items during sending:
	Sa 37A, Sa 38, Sa 39, Sa 40, Sa 41, Sa 42, Sa 43, Sa 57, Sa 58, Sa 59B, Sa 60, Sa 61
	Approval of the following items during receiving:
	Sa 31B, Sa 32, Sa 33, Sa 34, Sa 35, Sa 36, Sa 44, Sa 45, Sa 46, Sa 47
Test summary	To test the establishment of a connection, which is rejected by the called SaS user
Test preamble	The IUT and the test environment have to be brought into the IDLE state.
Constraints	Keys according to used ETCS-ID's are available.
Test body	<ul style="list-style-type: none"> - The IUT receives a T-Conn.ind (including AU1 SaPDU) from test environment. - The IUT generates a T-Conn.resp containing an AU2 SaPDU. - The test environment accepts the response and answers with a T-Data.req containing an AU3 SaPDU. - The IUT receives the T-Data.ind containing this AU3 SaPDU. - Connection establishment is indicated to the SaS user by Sa-Conn.ind primitives. - SaS user rejects the connection using a Sa-Disc.req with a certain reason code. - The IUT generates a T-Discon.req containing a DI SaPDU (reason 0, subreason according to received reason code from theSaS user).
Verdict criteria	If the SaPDU's and the Sa-Primitives conform to the requested pattern => PASS
Test postamble	

The IUT and the test environment are in the IDLE state.

Comments

See Figure 15

Table 31 – Connection establishment (incoming request) – not confirmed

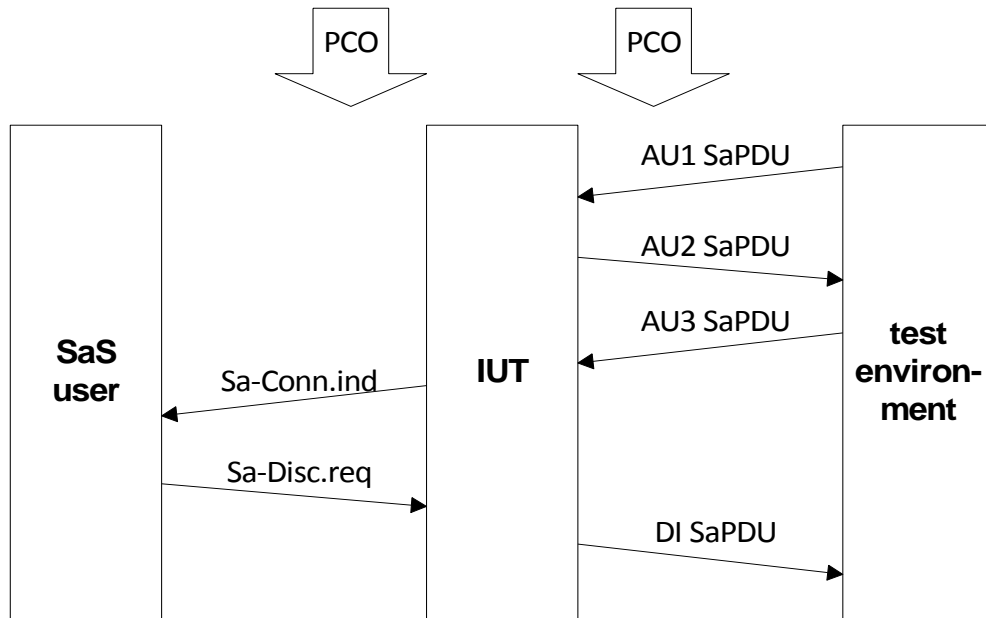

Figure 15 – Normal order of events (incoming connect request not confirmed)

5.4 Transfer of normal and high priority data

5.4.1 Normal order of events

Header	Transfer of normal and high priority data
TC No.:	32
TC covers the following items of [2]: Sa 5, Sa 6, Sa 10, Sa 11, Sa 25, Sa 26, Sa 27, Sa 28, Sa 52, Sa 53, Sa 54A, Sa 54B, Sa 55, Sa 56, Sa 62	
Test summary	To test the transmission and receiving of normal and high priority data
Test preamble	<p>Test have to be executed twice, once with each preamble:</p> <ul style="list-style-type: none"> The IUT and the test environment have to be brought into the DATA state after successful connection establishment response (IUT with RBC role) The IUT and the test environment have to be brought into the DATA state after successful connection establishment confirmation (IUT with OBU role)
Constraints	

Test body

- The transfer of normal user data is requested continuously by repeated Sa-DATA.req primitives (from the SaS user in certain ratio), contents of the user data according to prepared test patterns. The IUT receives the T-DATA.ind (including a DT SaPDU) issued from the test environment in certain ratio, contents of user data according to prepared test patterns.
- RBC role: The IUT receives Sa-HP-DATA.req (including HP data) from the SaS user in certain ratio.
- OBU role: The IUT receives T-HP-DATA.ind (including HP SaPDU) issued from the test environment in certain ratio. Data received from the test environment are indicated to the IUT by Sa-DATA.ind and Sa-HP-Data.ind primitives.

Verdict criteria

If the user data received by the IUT / test environment are equal to the prepared test pattern and the sequence internally to each type are correct => PASS

Test postamble

The IUT and the test environment are in the DATA state.

Comments

See Figure 16

HP data transfer is neither supported in PS mode nor in the direction OBU to RBC in CS mode.

Table 32 – Data Transfer

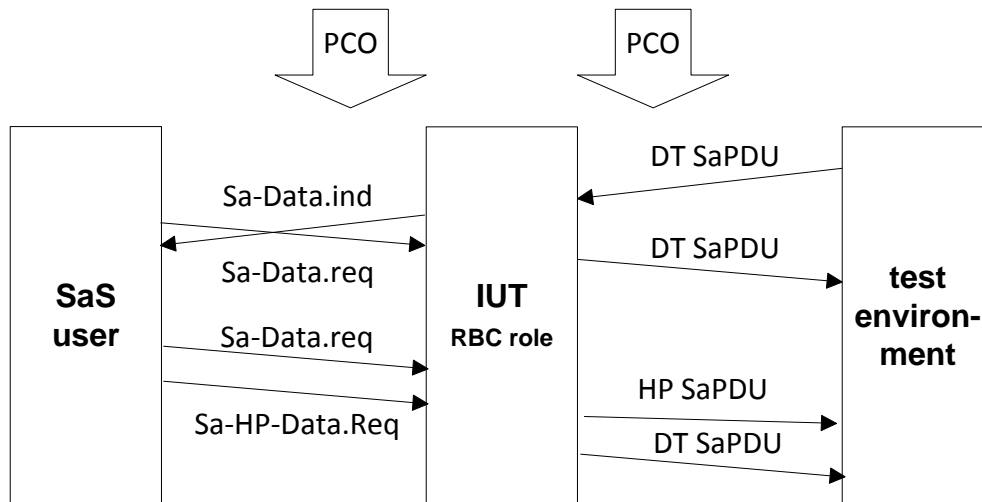

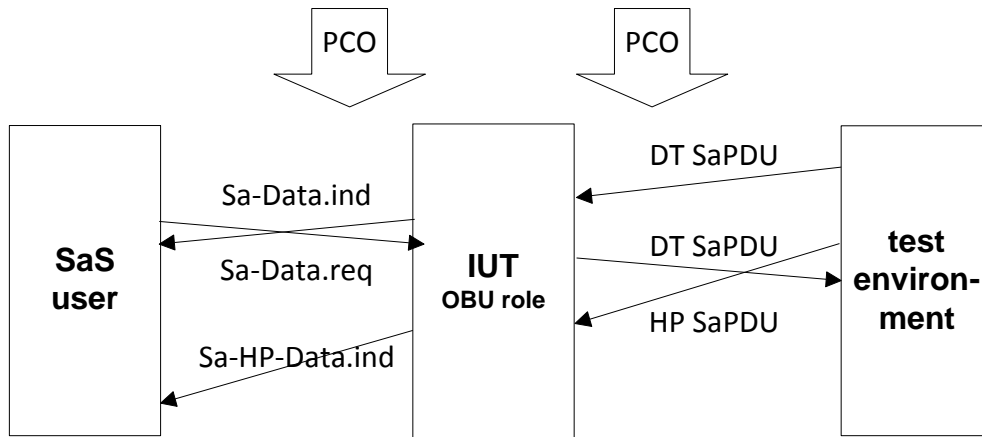

Figure 16 – Data transfer

5.4.2 Error case – Reception of messages with a wrong MTI

Header	Reception of messages with an wrong MTI
TC No.:	33
TC covers the following items of [2]: Sa 91	
Test summary	To test the error reaction with a wrong MTI
Test preamble	The IUT and the test environment have to be brought into the DATA state.
Constraints	
Test body	<ul style="list-style-type: none"> - The test environment sends SaPDU's with an undefined MTI field (one test for each of the following values: '0000', '0100', '0110', '0111', '1010', '1101', '1110', '1111'), these SaPDU's are received by the IUT. - The IUT rejects this message and sends a T-Disc.req containing a DI SaPDU and a Sa-Disc.ind; both with reason 8, subreason 1.
Verdict criteria	If the Sa-Primitive and the SaPDU conform to the requested test pattern and no indication of the faulty SaPDU => PASS
Test postamble	The IUT and the test environment are in the IDLE state.
Comments	See Figure 17

Table 33 – Reception of message with wrong MTI

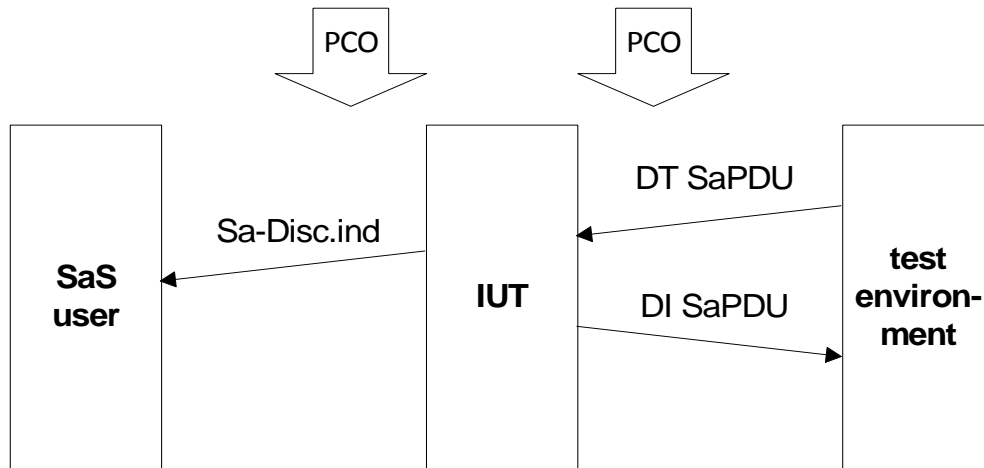

Figure 17 – Reception of a wrong DT SaPDU

5.4.3 Error case – Reception of DT SaPDU, which is too short

Header	Reception of DT SaPDU, which is too short
TC No.:	34
TC covers the following items of [2]:	<p>Sa 8, Sa 95E</p> <p>Approval of the following items during sending: Sa 57, Sa 58, Sa 59 (A or B), Sa 60, Sa 61</p> <p>Approval of the following items during receiving: Sa 53</p>
Test summary	To test the error reaction related to DT SaPDU's which are outside the valid length range
Test preamble	The IUT and the test environment have to be brought into the DATA state.
Constraints	
Test body	<ul style="list-style-type: none"> - The test environment sends a DT SaPDU with a total length of 9 octets (no user data included), this SaPDU is received by the IUT. - The IUT rejects this message and sends a T-Disc.req containing a DI SaPDU and a Sa-Disc.ind; both with reason 10, subreason 5.
Verdict criteria	If the Sa-Primitive and the SaPDU conform to the requested pattern and no indication of the faulty SaPDU occurs => PASS
Test postamble	The IUT and the test environment are in the IDLE state.

Comments

See Figure 17

Table 34 – Reception of a too short data SaPDU

5.4.4 Error case – Reception of DT SaPDU, which is too long

Header	Reception of DT SaPDU, which is too long
TC No.:	35
TC covers the following items of [2]:	Sa 8, Sa 96E
	Approval of the following items during sending: Sa 57, Sa 58, Sa 59 (A or B), Sa 60, Sa 61
	Approval of the following items during receiving: Sa 53
Test summary	To test the error reaction related to DT SaPDU's outside the valid length range
Test preamble	The IUT and the test environment have to be brought into the DATA state.
Constraints	
Test body	<ul style="list-style-type: none"> - The test environment sends a DT SaPDU with a total length of 1033 octets (user data 1024 octets), this SaPDU is received by the IUT. - The IUT rejects this message and sends a T-Disc.req containing a DI SaPDU and a Sa-Disc.ind; both with reason 10, subreason 5.
Verdict criteria	If the Sa-Primitive and the SaPDU conform to the requested pattern and no indication of the faulty SaPDU occurs => PASS
Test postamble	The IUT and the test environment are in the IDLE state.
Comments	See Figure 17

Table 35 – Reception of a too short data SaPDU

5.4.5 Error case – Reception of DT SaPDU with wrong direction flag

Header	Reception of DT SaPDU (wrong direction flag)
TC No.:	36
TC covers the following items of [2]:	Sa 8, Sa 87D

<p>Approval of the following items during sending: Sa 57, Sa 58, Sa 59 B, Sa 60, Sa 61</p> <p>Approval of the following items during receiving: Sa 53</p>
<p>Test summary</p> <p>To test the error reaction related to DT SaPDU's with wrong direction flag.</p>
<p>Test preamble</p> <p>The IUT has to be brought into the DATA_{called} state, the test environment is therefore in the state DATA_{calling}.</p>
<p>Constraints</p>
<p>Test body</p> <ul style="list-style-type: none"> - The test environment (initiator of a connection) sends a DT SaPDU where the direction flag is '1', this SaPDU is received by the IUT. - The IUT rejects this message and sends a T-Disc.req containing a DI SaPDU and a Sa-Disc.ind; both with reason 6, subreason 2.
<p>Verdict criteria</p> <p>If the Sa-Primitive and the SaPDU's conform to the requested test pattern (including user data according to the prepared test pattern) => PASS</p>
<p>Test postamble</p> <p>The IUT and the test environment are in the IDLE state.</p>
<p>Comments</p> <p>See Figure 17</p>

Table 36 – Reception SaPDU with wrong direction flag

5.4.6 Error case – Reception of DT SaPDU with wrong direction flag

<p>Header Reception of DT SaPDU (wrong direction flag)</p> <p>TC No.: 37</p> <p>TC covers the following items of [2]: Sa 8, Sa 87D</p> <p>Approval of the following items during sending: Sa 57, Sa 58, Sa 59 A, Sa 60, Sa 61</p> <p>Approval of the following items during receiving: Sa 53</p>
<p>Test summary</p> <p>To test the error reaction related to DT SaPDU's with wrong direction flag.</p>
<p>Test preamble</p> <p>The IUT has to be brought into the DATA_{calling} state, the test environment is therefore in the state DATA_{called}.</p>
<p>Constraints</p>
<p>Test body</p>

<ul style="list-style-type: none"> - The test environment (called party of the connection) sends a DT SaPDU where the direction flag is '0'), this SaPDU is received by the IUT. - The IUT rejects this message and sends a T-Disc.req containing a DI SaPDU and a Sa-Disc.ind; both with reason 6, subreason 1.
<p>Verdict criteria</p> <p>If the Sa-Primitive and the SaPDU's conform to the requested test pattern (including user data according to the prepared test pattern) => PASS.</p>
<p>Test postamble</p> <p>The IUT and the test environment are in the IDLE state.</p>
<p>Comments</p> <p>See Figure 17</p>

Table 37 – Reception SaPDU with wrong direction flag

5.4.7 Error case – Reception of DT SaPDU with wrong MAC

<p>Header Reception of DT SaPDU (wrong MAC)</p> <p>TC No.: 38</p> <p>TC covers the following items of [2]: Sa 9, Sa 84</p> <p style="padding-left: 40px;">Approval of the following items during receiving: Sa 52, Sa 53, Sa 54 (A or B), Sa 55</p>
<p>Test summary</p> <p>To test the error reaction related to DT SaPDU's with wrong MAC</p>
<p>Test preamble</p> <p>The IUT and the Test equipment have to be brought into the DATA state.</p>
<p>Constraints</p>
<p>Test body</p> <ul style="list-style-type: none"> - The test environment sends a DT SaPDU where the MAC is wrong (corruption created by test equipment after correct MAC calculation)), this SaPDU is received by the IUT. - The IUT rejects this message and sends a Sa-Report.ind with reason 4, subreason 1. If the optional Sa-REPORT.indication is not supported by IUT, no indication to SaS user occurs. - The transfer of at least one user data message is requested from the test environment by DT SaPDU, contents of the user data according to prepared test patterns. - Received data (only the correct one) are indicated to the SaS user by Sa-DATA.ind primitives.
<p>Verdict criteria</p> <p>If the Sa-Primitive is conform to the requested test pattern => PASS</p>
<p>Test postamble</p> <p>The IUT and the test environment are in the DATA state.</p>
<p>Comments</p> <p>See Figure 18</p>

Table 38 – Reception of DT SaPDU with wrong MAC

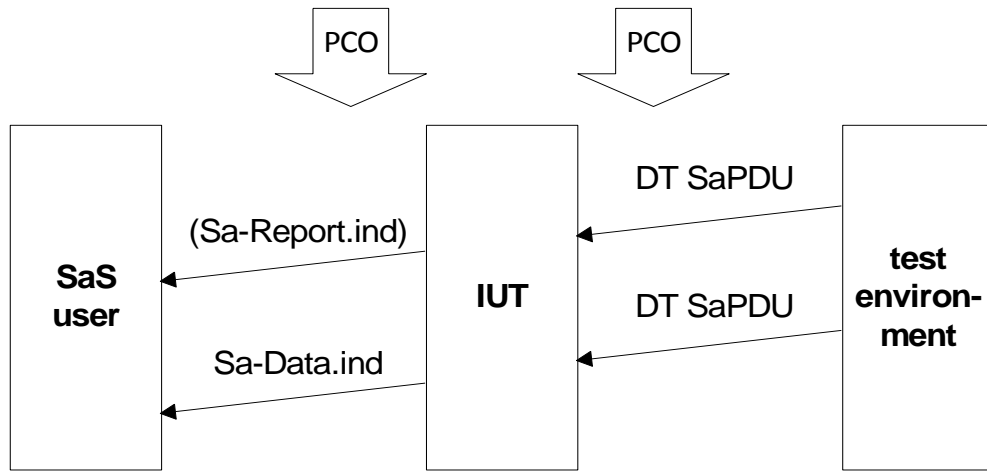

Figure 18 – Reception of DT SaPDU with wrong MAC

5.5 Disconnect request (outgoing request)

5.5.1 Normal order of events

Header	Disconnect request (outgoing request)
TC No.:	39
TC covers the following items of [2]:	Sa 7, Sa 30
Approval of the following items during sending:	Sa 57, Sa 58, Sa 59 (A or B), Sa 60, Sa 61
Test summary	To test the disconnect procedure, initiated by the local SaS user
Test preamble	The IUT and the test environment have to be brought into the DATA state.
Constraints	
Test body	<ul style="list-style-type: none"> - The IUT receives a Sa-Disc.req including reason and subreason. - The IUT generates a T-Disc.req containing a DI SaPDU.
Verdict criteria	If the SaPDU and the T-Primitive conform to the requested pattern => PASS.
Test postamble	The IUT and the test environment are in the IDLE state.
Comments	See Figure 19

Table 39 – disconnect request (outgoing request)

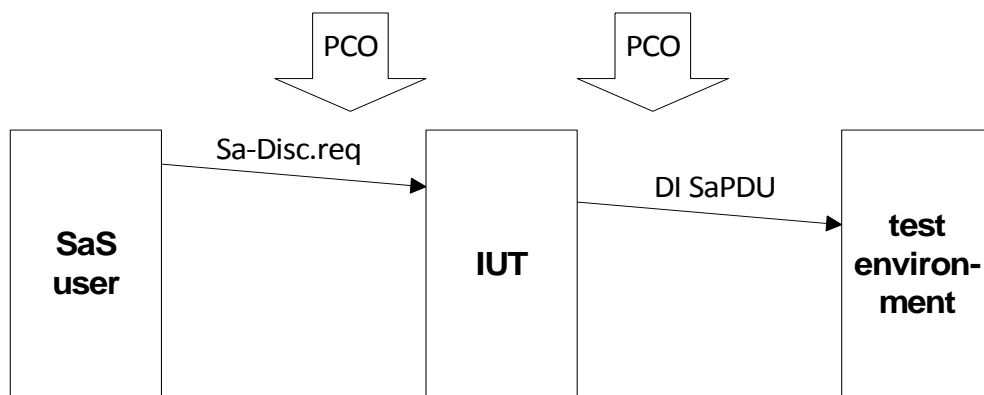

Figure 19 – Disconnect request (outgoing request)

5.6 Disconnect request (incoming request)

5.6.1 Normal order of events

<p>Header Disconnect request (incoming request)</p> <p>TC No.: 40</p> <p>TC covers the following items of [2]: Sa 8, Sa 29</p> <p style="padding-left: 40px;">Approval of the following items during receiving: Sa 57, Sa 58, Sa 59 (A or B), Sa 60, Sa 61</p>
<p>Test summary</p> <p>To test the disconnect procedure, initiated by the remote entity</p>
<p>Test preamble</p> <p>The IUT and the test environment have to be brought into the DATA state.</p>
<p>Constraints</p>
<p>Test body</p> <ul style="list-style-type: none"> - The IUT receives a T-Disc.ind including a DI SaPDU. - The IUT generates a Sa-Disc.ind containing a reason, subreason according to the values of the DI SaPDU.
<p>Verdict criteria</p> <p>If the Sa-Primitive conform to the requested pattern => PASS.</p>
<p>Test postamble</p> <p>The IUT and the test environment are in the IDLE state.</p>
<p>Comments</p> <p>See Figure 20</p>

Table 40 – disconnect request (incoming request)

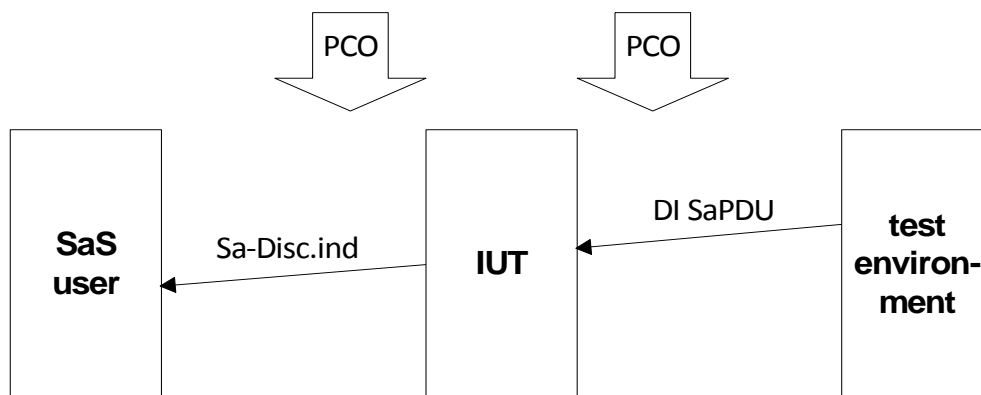

Figure 20 – Disconnect request (incoming request)

5.6.2 Error case - No transport service available

Header Disconnect request (incoming request)
TC No.: 41
TC covers the following items of [2]: Sa 8, Sa 80
Test summary
To test the disconnect procedure, initiated by the Communication Functional Module.
Test preamble
The IUT and the test environment have to be brought into the DATA state.
Constraints
Test body
<ul style="list-style-type: none"> - The IUT receives a T-Disc.ind including a parameter reason, but no user data. - The IUT generates a Sa-Disc.ind containing a reason code 1, the subreason code is mapped according to the field reason of T-Disc.ind.
Verdict criteria
If the Sa-Primitive conform to the requested pattern => PASS.
Test postamble
The IUT and the test environment are in the IDLE state.
Comments
See Figure 21

Table 41 – disconnect request (incoming request) – no transport service available

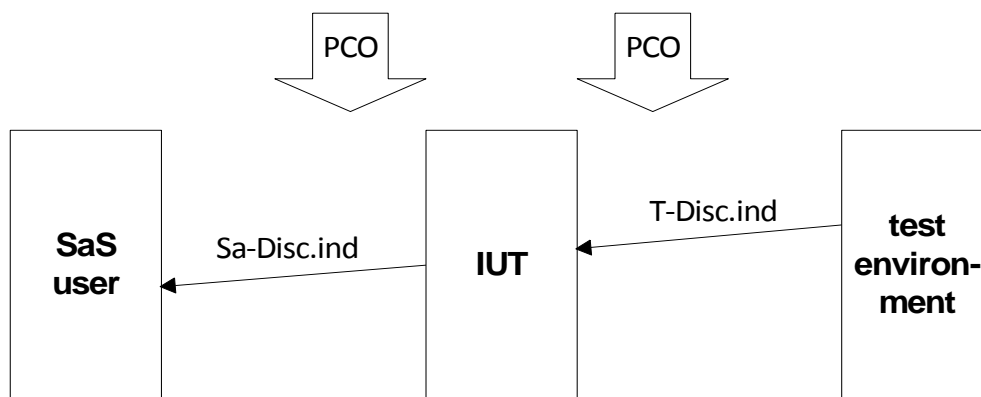

Figure 21 – Disconnect request (incoming request) – no transport service available

5.6.3 Error case – Reception of an DI SaPDU with wrong direction flag

Header Disconnect request (incoming request with wrong direction flag)
TC No.: 42

<p>TC covers the following items of [2]:</p> <p style="padding-left: 40px;">Sa 8, Sa 86</p> <p style="padding-left: 40px;">Approval of the following items during receiving:</p> <p style="padding-left: 80px;">Sa 57, Sa 58, Sa 59 (A or B), Sa 60, Sa 61</p>
<p>Test summary</p> <p>To test the disconnect procedure, initiated by the remote entity, but DI SaPDU includes a wrong direction flag</p>
<p>Test preamble</p> <p>The IUT and the test environment have to be brought into the DATA state.</p>
<p>Constraints</p>
<p>Test body</p> <ul style="list-style-type: none"> - The test environment generates a T-Disc.ind including a DI SaPDU, but the direction flag is <ul style="list-style-type: none"> If the IUT is the called entity: '1' If the IUT is the calling entity: '0' - The IUT generates a Sa-Disc.ind containing the reason 6, subreason 1 (if IUT is calling entity) and subreason 2 (if IUT is called entity).
<p>Verdict criteria</p> <p>If the Sa-Primitive according to the requested pattern => PASS.</p>
<p>Test postamble</p> <p>The IUT and the test environment are in the IDLE state.</p>
<p>Comments</p> <p>See Figure 20</p>

Table 42 – disconnect request (incoming request)

5.6.4 Error case – Reception of an DI SaPDU with changed first octet

<p>Header Disconnect request (incoming request)</p> <p>TC No.: 43</p> <p style="padding-left: 40px;">TC covers the following items of [2]: Sa 8, Sa 88D</p> <p style="padding-left: 40px;">Approval of the following items during receiving:</p> <p style="padding-left: 80px;">Sa 57, Sa 58, Sa 59 (A or B), Sa 60, Sa 61</p>
<p>Test summary</p> <p>To test the disconnect procedure, initiated by the remote entity</p>
<p>Test preamble</p> <p>The IUT and the test environment have to be brought into the DATA state.</p>
<p>Constraints</p>
<p>Test body</p>

- The IUT receives a T-Disc.ind including a DI SaPDU, but the bits 8,7,6 of the first octet are not equal to '000' (all other fields of the message are correct).
- The IUT generates an Sa-Disc.ind containing a reason , subreason according to the received DI SaPDU.

Verdict criteria

If the Sa-Primitive conform to the requested pattern => PASS.

Test postamble

The IUT and the test environment are in the IDLE state.

Comments

See Figure 20

Table 43 – disconnect request (incoming request)

6. OVERVIEW OF TEST CASE BEHAVIOUR

- 6.1.1.1 Figure 23 shows an overview of the required input and output states of the test cases described above. Test cases can be combined during execution, if the following test case starts at the final test state of the previous test case.
- 6.1.1.2 Numbers (connected to each line) refers to the test cases and each line goes from the input state to the output state according to the following figure:

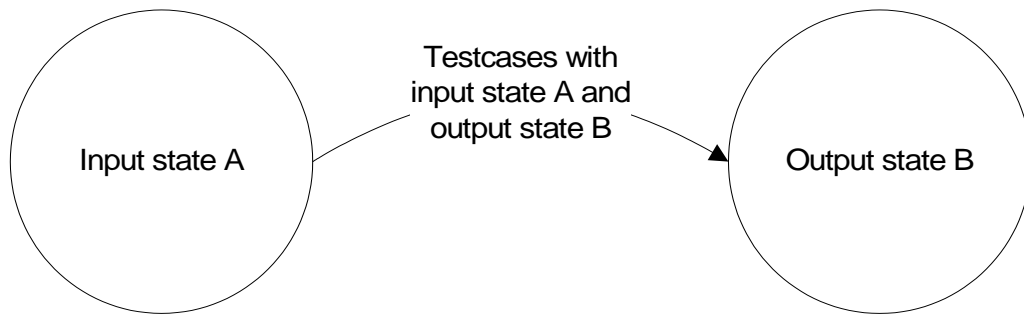

Figure 22 – Structure of a state transition

3, 4, 5, 6, 7, 8, 9, 10, 11, 12, 13, 14, 15, 16, 17, 18, 19, 21, 22, 23, 24, 25, 26, 27, 28, 29, 30, 31, 32, 33, 34

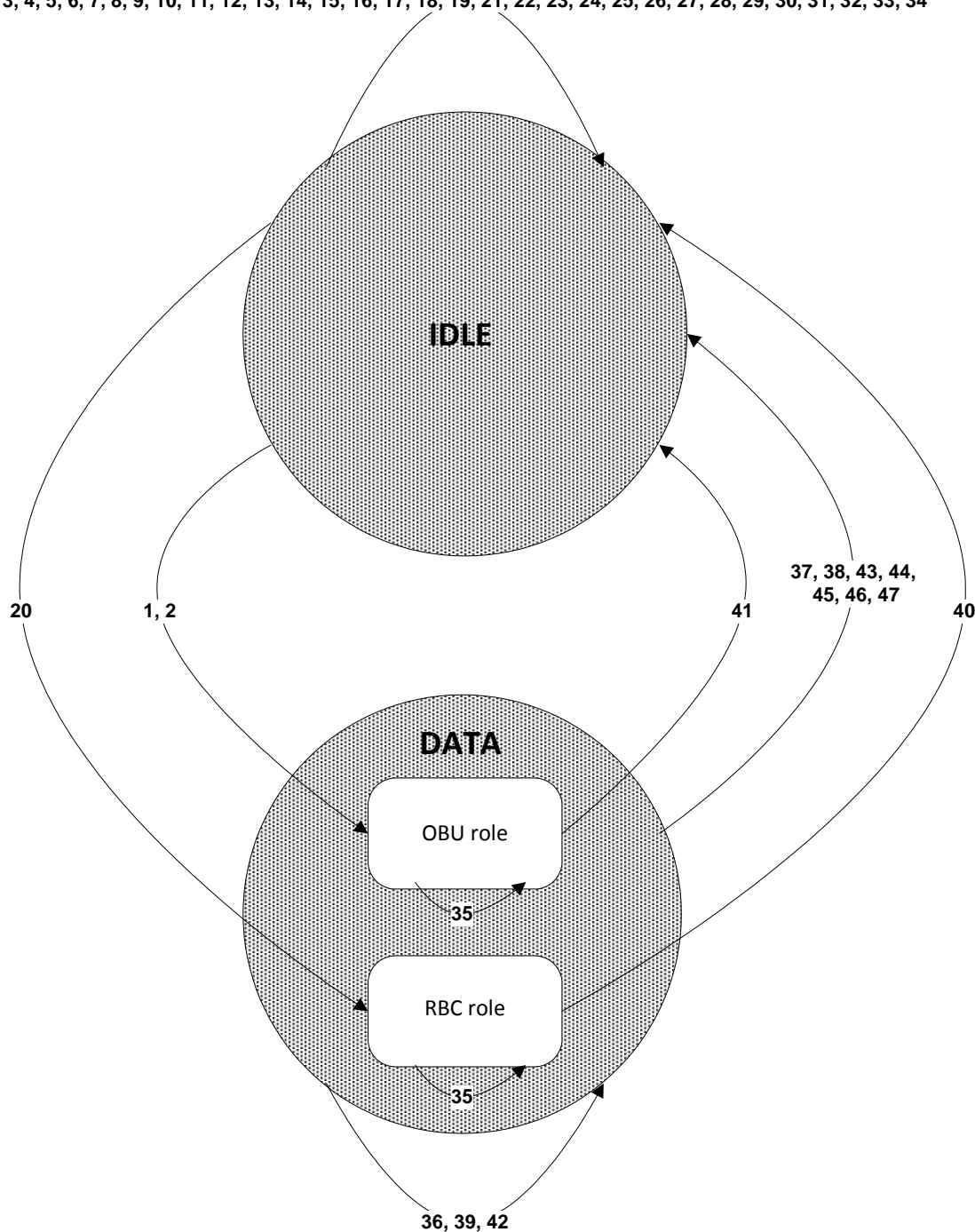

Figure 23 – Overview about test cases and input / output states

6.1.1.3 The state “Data” can be split into the sub-states “IUT with OBU role” and “IUT with RBC role”, but these sub-states are only relevant for test cases 35, 40 and 41. The test cases 36...39 and 42...47 use the state data independently from the sub-states. The output state of test cases 1, 2 and 20 is also “Data”, only the sub-state is different.