

ERTMS/ETCS

Test Specification for Eurobalise FFFIS

REF : SUBSET-085

ISSUE : 3.0.0

DATE : February 24, 2012

Company	Technical Approval	Management approval
ALSTOM		
ANSALDO		
BOMBARDIER		
INVENSYS		
SIEMENS		
THALES		

Modification History

Issue Date	Section Number	Modification/Description	Author
2.3.0 2011-08-08		The following technical modifications relative to version 2.2.2 apply to this version: <ul style="list-style-type: none">In section 5.2.13, testing is performed with Standard Size Balise only. Other modifications herein are either clarifications, and/or made for improving the general quality of the specification.	Per Lundberg
2.3.1 2011-09-30	E4.3.2 E4.3.3 G2	Modifications according to imperfections 085:521 and 085:526.	Per Lundberg
2.3.2 2012-02-01	4.2.5.4.1 5.2.5.3 5.2.10.2.1 5.2.10.2.2 B5.3.1 B5.3.2	Modifications according to imperfections 085:533 and 085:534 after WGI meeting on January 31 2012.	Per Lundberg
2.3.3 2012-02-09		Removal of "Class 1" on the front page.	Per Lundberg
3.0.0 2012-02-24		Baseline 3 release version (only change of Issue number).	Per Lundberg

Foreword

The main body of this specification, and the relevant Annexes designated as “normative”, constitute the mandatory requirements for test methods and tools for verification of compliance with the mandatory requirements of UNISIG SUBSET-036. Annexes designated as “informative”, either provide background information, or outline non-mandatory requirements and optional features.

Contents

1	INTRODUCTION	18
2	NORMATIVE REFERENCES	19
3	TERMINOLOGY AND DEFINITIONS	19
3.1	Acronyms and Abbreviations	19
3.2	Definitions	20
3.3	Influence of Tolerances	20
4	TESTS OF THE UP-LINK BALISE	21
4.1	Reference Test Configurations	21
4.1.1	General	21
4.1.2	Monitored Interfaces	22
4.1.3	Test Tools and Procedures	22
4.2	Laboratory Tests	23
4.2.1	Generic Test and Calibration Set-up notes	23
4.2.2	Up-link Field Conformity	25
4.2.2.1	General	25
4.2.2.2	Calibration of 4.2 MHz Balise Loop Current in the Main Lobe Zone	26
4.2.2.3	Balise Up-link Conformity Measurements in the Main Lobe Zone	28
4.2.2.4	Evaluation of Up-link Conformity in the Main Lobe Zone	30
4.2.2.5	Calibration of 4.2 MHz Balise Loop Current in the Side Lobe Zone	31
4.2.2.6	Up-link Reference Field in the Side Lobe Zone	31
4.2.2.7	Balise Up-link Conformity Measurements in the Side Lobe Zone	31
4.2.2.8	Evaluation of Up-link Conformity in the Side Lobe Zone	32
4.2.2.9	Calibration of 4.2 MHz Balise Loop Current in the Cross-talk Protected Zone	33
4.2.2.10	Up-link Reference Field in the Cross-talk Protected Zone	35
4.2.2.11	Balise Up-link Conformity Measurements in the Cross-talk Protected Zone	36
4.2.2.12	Evaluation of Up-link Conformity in the Cross-talk Protected Zone	37
4.2.3	Tele-powering Field Conformity	38
4.2.3.1	General	38
4.2.3.2	Calibration of 27 MHz Tele-powering flux in the Main Lobe Zone	39
4.2.3.3	Balise Tele-powering Conformity Measurements in Main Lobe Zone	42
4.2.3.4	Evaluation of Tele-powering Conformity in the Main Lobe Zone	44
4.2.3.5	Calibration of 27 MHz Tele-powering flux in the Side Lobe Zone	45

4.2.3.6	Tele-powering Reference Field in the Side Lobe Zone	45
4.2.3.7	Balise Tele-powering Conformity Measurements in the Side Lobe Zone	46
4.2.3.8	Evaluation of Tele-powering Conformity in the Side Lobe Zone	46
4.2.4	I/O Characteristics	47
4.2.4.1	General	47
4.2.4.2	Calibration of 4.2 MHz for Balise Input to Output Characteristics	48
4.2.4.3	Balise Input to Output Characteristics Measurements	50
4.2.4.4	Evaluation of I/O Characteristics	53
4.2.5	Cross-talk Immunity with Cables	54
4.2.5.1	General	54
4.2.5.2	Calibration of 27 MHz Tele-powering flux	54
4.2.5.3	Calibration of Balise response	56
4.2.5.4	Cross-talk Measurements	59
4.2.5.5	LZB Cable Testing	62
4.2.6	Balise Impedance	66
4.2.6.1	General	66
4.2.6.2	Test Conditions	67
4.2.6.3	Calibration of 27 MHz Tele-powering flux	68
4.2.6.4	Balise Impedance Measurements	69
4.2.7	Up-link Signal Characteristics	72
4.2.7.1	General	72
4.2.7.2	Nominal Test Conditions	73
4.2.7.3	Specific Test Conditions	76
4.2.7.4	Toggling AM Test Conditions	77
4.2.7.5	Calibration of 27 MHz Tele-powering flux	79
4.2.7.6	Test of Centre Frequency and Frequency Deviation	81
4.2.7.7	Test of Start-up after Side Lobe	82
4.2.7.8	Test of Mean Data Rate	82
4.2.7.9	Test of MTIE (Maximum Time Interval Error)	83
4.2.7.10	Test of Amplitude Jitter during start-up ramp	83
4.2.7.11	Test of Amplitude Jitter during steady state flux	84
4.2.7.12	Test of Signal Bandwidth	84
4.2.7.13	Test of Delay Time and Balise controlling interface Parameter Variation	84
4.2.7.14	Test of Compatibility	85
4.2.7.15	Test of Balise start with Toggling AM and steep Tele-powering slope	85
4.2.7.16	Test Matrices	86
4.2.8	Balise controlling interface performance measurements	90

4.2.8.1	Introduction	90
4.2.8.2	General Test Conditions	90
4.2.8.3	Electrical Data Requirements	91
4.2.8.4	Calibration of the 27 MHz Tele-powering flux	96
4.2.8.5	Functional Tests	98
4.2.9	Test for damaging	110
4.2.9.1	General	110
4.2.9.2	Calibration of Tele-powering flux level	110
4.2.9.3	Test Procedure, Test for damaging	110
4.3	Requirements for Test Tools	110
5	TESTS OF THE ON-BOARD EQUIPMENT	111
5.1	Reference Test Configurations	111
5.1.1	General	111
5.1.2	Monitored Interfaces	111
5.1.3	Test Tools and Procedures	112
5.2	Laboratory Tests	113
5.2.1	General	113
5.2.1.1	Introduction	113
5.2.1.2	General Test Set-up	114
5.2.1.3	Test Set-up Notes	115
5.2.2	Test Conditions	116
5.2.2.1	Nominal Conditions	116
5.2.2.2	Specific Conditions	118
5.2.3	Evaluation of Radiation Pattern	120
5.2.3.1	General Description	120
5.2.3.2	Test Procedure, Evaluation of Radiation Pattern	122
5.2.4	Creation of Signal Pattern for Dynamic Tests	124
5.2.4.1	General Description	124
5.2.4.2	Example of Signal Pattern Generation	126
5.2.4.3	Example of Algorithm for Signal Pattern Generation	128
5.2.5	Transmission Tests	130
5.2.5.1	General Description	130
5.2.5.2	Test Procedure, Transmission Tests	131
5.2.5.3	Acceptance Criteria, Transmission Tests	134
5.2.6	Electrical Tele-powering Characteristics	134
5.2.6.1	General Description	134

5.2.6.2	Test Set-up for Tele-powering verification	135
5.2.6.3	Test Procedure, CW Mode	136
5.2.6.4	Test Procedure, Interoperable Mode	137
5.2.6.5	Acceptance Criteria, Electrical Tele-powering Characteristics	138
5.2.7	Maximum Flux Level	138
5.2.7.1	General Description	138
5.2.7.2	Test Set-up for Maximum Flux Level verification	139
5.2.7.3	Test Procedure, Maximum Flux Level	140
5.2.7.4	Acceptance Criteria, Maximum Flux Level	140
5.2.8	Electrical Up-link Signal Characteristics	141
5.2.8.1	General Description	141
5.2.8.2	Test Procedure, Electrical Up-link Characteristics	141
5.2.8.3	Test Cases	142
5.2.8.4	Acceptance Criteria, Electrical Up-link Characteristics	142
5.2.9	Cross-talk Immunity	143
5.2.9.1	General Description	143
5.2.9.2	Test Procedure, Cross-talk Immunity	144
5.2.9.3	Acceptance Criteria, Cross-talk Immunity	145
5.2.10	Cross-talk Immunity with Cables	146
5.2.10.1	General	146
5.2.10.2	Cross-talk Measurements	147
5.2.10.3	LZB Cable Testing	151
5.2.11	Balise Detectability Supervision	154
5.2.11.1	General Description	154
5.2.11.2	Acceptance Criteria, Balise Detectability Supervision	154
5.2.12	Handling of various Telegrams	155
5.2.12.1	General Description	155
5.2.12.2	Test Procedure, Handling of various Telegrams	155
5.2.12.3	Acceptance Criteria, Handling of various Telegrams	155
5.2.13	Handling of Balise Sequences	156
5.2.13.1	General Description	156
5.2.13.2	Test Procedure, Handling of Balise Sequences	156
5.2.13.3	Acceptance Criteria, Handling of Balise Sequences	157
5.2.14	Fundamental concepts of Basic Receiver	158
5.2.14.1	General Description	158
5.2.14.2	Test Procedure, Fundamental concepts of Basic Receiver	158
5.2.14.3	Acceptance Criteria, Fundamental concepts of Basic Receiver	159

5.3	Requirements for Test Tools	159
	ANNEX A (NORMATIVE), REFERENCE TEST TELEGRAMS	160
A1	GENERAL	160
A2	TEST TELEGRAMS	161
A3	SPECIFIC TEST TELEGRAMS	166
	ANNEX B (NORMATIVE), AIR-GAP REFERENCE EQUIPMENT	168
B1	GENERAL	168
B2	REFERENCE LOOPS	168
B2.1	Size of Reference Loops	168
B2.2	Field Requirements	169
B2.2.1	Magnetic Field (H-field)	169
B2.2.2	Electric Field (E-field)	170
B2.3	Compensation for the Impedance of the Reference Loop	171
B2.4	Frequency Characteristics of the Reference Field	172
B2.5	Influence of Debris	172
B2.5.1	The flux through the Reference Area	172
B2.5.2	The field from the Balise	172
B2.6	Conformity Testing of Reference Loops	173
B2.6.1	Test Procedure	173
B2.6.2	Measurement set-up	174
B2.6.3	Instrument set-up and Calibration	175
B2.6.4	Compensation for the impedance of the Reference Loop	175
B2.6.5	Test Environment	177
B2.6.6	Calculation of correction factors	177
B2.6.7	Labelling and Marking of Reference Loops	179
B2.7	Application for Reference Loop Calibration	180
B2.7.1	General	180
B2.7.2	Standard Size Reference Loop	181
B2.7.3	Reduced Size Reference Loop	185
B3	TEST ANTENNA	189
B3.1	Size of the Test Antenna	189
B3.2	Field Requirements	189
B3.3	Impedance	189

B4	ACTIVATION ANTENNA	190
B4.1	Size of the Activation Antenna	190
B4.2	Field Requirements	190
B4.3	Impedance	190
B5	CONDITIONS TO BE TESTED	190
B5.1	General	190
B5.2	Debris	191
B5.2.1	General	191
B5.2.2	Liquid Debris	191
B5.2.3	Non-liquid Debris	192
B5.2.4	Reference Loop and Balise	193
B5.2.4.1	Salt Water	193
B5.2.4.2	Clear Water	193
B5.2.4.3	Iron Ore (Magnetite)	193
B5.2.4.4	Iron Ore (Hematite)	193
B5.2.4.5	Fresh Snow	193
B5.2.4.6	Wet Snow	194
B5.2.4.7	Ice	194
B5.2.4.8	Ballast	194
B5.2.4.9	Dry Sand	194
B5.2.4.10	Wet Sand	194
B5.2.4.11	Mud without Salt Water	194
B5.2.4.12	Mud with Salt Water	194
B5.2.4.13	Iron Dust	195
B5.2.4.14	Coal Dust	195
B5.2.4.15	Oil and Grease	195
B5.2.5	Antenna	195
B5.2.5.1	Ice	195
B5.2.5.2	Fresh Snow	195
B5.2.5.3	Wet Snow	195
B5.2.5.4	Mud without Salt Water	196
B5.2.5.5	Mud with Salt Water	196
B5.2.5.6	Iron Ore (Magnetite)	196
B5.2.5.7	Iron Ore (Hematite)	196
B5.2.5.8	Iron Dust	196
B5.2.5.9	Coal Dust	196

B5.2.5.10	Oil and Grease	196
B5.3	Metallic Objects	197
B5.3.1	Iron Bars outside the metallic free volume of the Balise	197
B5.3.2	Guard Rails	198
B5.3.3	Metallic Plane underneath the Balise	199
B5.3.4	Steel Sleepers	200
B5.3.5	Other Sleepers	201
B5.3.6	Loop Cable	201
B5.3.7	Metallic objects outside the metal free volume of the Antenna Unit	202
B5.3.8	Metallic Masses in the Track	204
ANNEX C (NORMATIVE), MEASUREMENT POINTS		205
C1	GEOMETRICAL TEST POINTS MAIN LOBE ZONE	205
C2	GEOMETRICAL TEST POINTS SIDE LOBE ZONE	206
C3	GEOMETRICAL TEST POINTS CROSS-TALK PROTECTED ZONE	207
C4	TEST POINTS FOR MAIN LOBE ZONE AND SIDE-LOBE ZONE	208
C5	TEST POINTS FOR CROSS-TALK PROTECTED ZONE	209
C6	TEST MATRIX FOR TRANSMISSION AND CROSS-TALK TESTS	210
C6.1	Test Conditions versus Test Zones	210
C6.2	Test Conditions versus Geometrical Test Points	211
C7	TEST MATRIX FOR OTHER CHARACTERISTICS	212
C7.1	Test Conditions versus Characteristics	212
C7.2	Test Conditions versus Geometrical Test Points	213
C7.3	Source of data for Controlled Balises versus Test Cases	214
ANNEX D (INFORMATIVE), DESCRIPTIONS OF TEST TOOLS		215
D1	DESCRIPTION OF TIME AND ODOMETER MODULE (LTOM)	215
D1.1	Operational Context	215
D1.2	Functional requirements	216
D1.2.1	Basic functions	216
D1.2.2	Operational modes	216
D1.2.2.1	General	216
D1.2.2.2	Idle or static mode	216
D1.2.2.3	Self-test mode	216

D1.2.2.4	Dynamic simulated mode	217
D1.2.2.5	Real dynamic mode	217
D1.3	External interfaces	218
D1.3.1	Interface T4	218
D1.3.2	Man Machine Interface	219
D1.3.3	Interface V2	219
D1.3.4	Interface V3	219
D1.3.5	Interface V4	220
D1.3.6	Interface S1	220
D1.3.7	Interface S2	220
D1.3.8	Interface S3	220
D1.3.9	Interface S4	220
D1.3.10	Interface S5	221
D1.4	Required performance	221
D2	DESCRIPTION OF REFERENCE SIGNAL GENERATOR (RSG)	222
D2.1	Operational Context	222
D2.2	Functional requirements	223
D2.2.1	Basic functions	223
D2.2.1.1	General	223
D2.2.1.2	RSG_1	224
D2.2.1.3	RSG_2	225
D2.2.1.4	RSG_C	225
D2.2.2	Operational modes	227
D2.2.2.1	RSG_1	227
D2.2.2.2	RSG_2	227
D2.2.2.3	RSG_C	228
D2.3	External interfaces	229
D2.3.1	RSG_1	229
D2.3.1.1	Interface with the LTMS	229
D2.3.1.2	Interface with the LTOM	229
D2.3.2	RSG_2	229
D2.3.2.1	Interface with the LTMS	229
D2.3.2.2	Test Antenna	229
D2.3.2.3	Current Sense (CS) from Test Antenna	230
D2.3.2.4	Interface with the LRRT	230
D2.3.3	RSG_C	230

D2.3.3.1	Interface with the LTMS	230
D2.3.3.2	Interface with the LTOM	230
D2.4	Required performance	231
D2.4.1	RSG_1	231
D2.4.2	RSG_2	231
D2.4.3	RSG_C	233
D3	DESCRIPTION OF ANTENNA POSITIONING TOOL (APT)	234
D3.1	Operational Context	234
D3.2	Functional requirements	235
D3.2.1	Basic functions	235
D3.2.2	Operational modes	236
D3.2.2.1	General	236
D3.2.2.2	Idle mode	236
D3.2.2.3	Self test mode	236
D3.2.2.4	Recovery of the lost position	236
D3.2.2.5	Quasi static antenna positioning	237
D3.2.2.6	Continuous longitudinal antenna movement	237
D3.3	External interfaces	238
D3.3.1	Interface T2	238
D3.3.2	Man Machine Interface	238
D3.3.3	Interface V3	239
D3.4	Required performance	239
D3.4.1	Test bed characteristics	239
D3.4.2	Positioning Accuracy	241
D4	DESCRIPTION OF OFF-LINE TELEGRAM GENERATOR (OLTG)	243
D4.1	Operational Context	243
D4.2	Functional requirements	244
D4.2.1	Basic functions	244
D4.2.2	Functional architecture	245
D4.3	External Interfaces	246
D4.3.1	User Data	246
D4.3.1.1	General	246
D4.3.1.2	Packet and variables representation	246
D4.3.1.3	Hexadecimal representation	246
D4.3.2	Telegram File	246

D4.3.3	Printout	246
D5	DESCRIPTION OF TEST MANAGEMENT SYSTEM (LTMS)	247
D5.1	Operational Context	247
D5.2	Functional requirements	248
D5.2.1	Basic Functions	248
D5.2.2	Operational Modes	249
D5.2.2.1	General	249
D5.2.2.2	Idle and self-test mode	249
D5.2.2.3	Test procedure control	250
D5.3	External Interfaces	257
D5.3.1	Man Machine Interface (MMI)	257
D5.3.2	Interface V1	258
D5.3.3	Interface T1	258
D5.3.4	Interface T2	258
D5.3.5	Interface T3	258
D5.3.6	Interface T4	258
D5.3.7	Interface T5	258
D5.3.8	Interface T6	258
D5.3.9	Interface T7	259
D5.4	Required Performance	259
D6	DESCRIPTION OF REFERENCE RECEIVER TOOL (LRRT)	260
D6.1	Operational Context	260
D6.2	Functional Requirements	261
D6.2.1	Basic Functions	261
D6.2.2	Operational Modes	262
D6.2.2.1	Idle and self-test mode	262
D6.2.2.2	Up-link signal analysis (LRRT_1)	262
D6.2.2.3	Tele-powering signal analysis (LRRT_2)	267
D6.2.2.4	Interface 'C' signal analysis (LRRT_C)	269
D6.3	External Interfaces	272
D6.3.1	Interface T1	272
D6.3.2	Fast trigger Interface S6	273
D6.3.3	Man Machine Interface – MMI	273
D6.4	Required Performance	274
D6.4.1	LRRT_1	274

D6.4.2	LRRT_2	274
D6.4.3	LRRT_C	274
ANNEX E (INFORMATIVE), TEST INTERFACES FOR THE ON-BOARD EQUIPMENT		275
E1	INTERFACE V1	275
E1.1	General	275
E1.2	Operational Data	275
E1.2.1	Mode Selection (TESTCONF)	275
E1.2.2	Mode Status (BTMSTAT)	276
E1.2.3	Link Status (ALIVE)	277
E1.3	Test Data	277
E1.3.1	Self-test Report (ANTTEST)	277
E1.3.2	Balise Passage Report (BALL_PASS)	278
E2	INTERFACE V2	280
E2.1	General	280
E2.2	Interface V2 Data	281
E3	INTERFACE V4	282
E3.1	General	282
E3.2	Interface V4 Signals	282
E4	PHYSICAL AND LINK CONTROL	283
E4.1	Architecture	283
E4.2	Physical Control	284
E4.2.1	General	284
E4.2.2	Interface 'V ₁ ', Mechanical Data	284
E4.2.3	Interface 'V ₂ ', Mechanical Data	286
E4.3	Link Control	288
E4.3.1	General	288
E4.3.2	Interface 'V ₁ '	288
E4.3.3	Interface 'V ₂ '	289
E4.4	Interface 'V₁' Link Synchronisation	291
E4.4.1	General	291
E4.4.2	Case 1 – The BTM is switched on before the Interface 'V ₁ ' driver	291
E4.4.3	Case 2 – The Interface 'V ₁ ' driver is switched on before the BTM	292
E4.4.4	Case 3 – The Interface 'V ₁ ' driver is re-started but the BTM remains on	293
E4.4.5	Case 4 – The BTM is re-started but the Interface 'V ₁ ' driver remains on	294

E4.4.6	Behaviour of the Interface 'V ₁ ' driver	295
ANNEX F (INFORMATIVE), TEST TOOLS AND INSTRUMENTS		297
F1	RECOMMENDED TEST TOOLS AND INSTRUMENTS	297
F2	RECOMMENDED HIGH POWER LOW PASS FILTER	299
F2.1	CHARACTERISTICS	299
F2.2	SUGGESTED IMPLEMENTATION	300
F2.3	INDUCTOR CHARACTERISTICS	301
F3	SPECIFIC LOW PASS FILTER CHARACTERISTICS	302
ANNEX G (INFORMATIVE), RECOMMENDED TEST PROCEDURES		303
G1	TESTING OF LEU OUTPUT RETURN LOSS	303
G1.1	Test Abstract	303
G1.2	Test Set-up for Interface 'C1'	303
G1.3	Calibration of the test set-up for Interface 'C1'	304
G1.4	Test Procedure for Interface 'C1'	304
G1.5	Test Set-up for Interface 'C6'	305
G1.6	Calibration of the test set-up for Interface 'C6'	306
G1.7	Test Procedure for Interface 'C6'	307
G2	HARMONIC CONTENTS ON THE INTERFACE 'C6' LEU OUTPUT	308
ANNEX H (INFORMATIVE), AIR-GAP REFERENCE EQUIPMENT		309
H1	GENERAL	309
H2	REFERENCE LOOPS	309
H2.1	Reference Loop Design	309
H2.1.1	Overall Design	309
H2.1.2	Loop Structure Mechanics	311
H2.1.3	Non-conductive Joints	312
H2.1.4	Printed Circuit Board	312
H2.1.5	PCB Components	312
H2.1.6	Encapsulation	313
H2.2	Utilisation of the Reference Loops	313
H2.3	Tuning of the Reference Loops	314

H2.4	Calibration of the Reference Loops	315
H3	TEST ANTENNAS	316
H3.1	General	316
H3.2	Test Antenna Design	317
H3.2.1	Overall Design	317
H3.2.2	Screen Plate	318
H3.2.3	Holder	318
H3.2.4	Loops	318
H3.2.4.1	General	318
H3.2.4.2	Capacitors	318
H3.2.4.3	Printed Circuit Board (PCB)	319
H3.2.4.4	27.095 MHz Transformer	319
H3.2.4.5	Current Sense Transformer and Current Probe	319
H3.2.4.6	4.23 MHz Transformer	320
H3.2.5	Balun	320
H3.3	Modified Test Antenna Design	320
H3.4	Tuning of Test Antenna	320
H3.5	Performance Check of Test Antenna	321
H4	ACTIVATION ANTENNAS	322
H4.1	General	322
H4.2	Activation Antenna Design	323
H4.2.1	Overall Design	323
H4.2.2	Spacer	324
H4.2.3	Loop	324
H4.2.3.1	General	324
H4.2.3.2	Capacitors	324
H4.2.3.3	Printed Circuit Board (PCB)	324
H4.2.3.4	27.095 MHz Transformer	325
H4.2.3.5	Current Sense Transformer and Current Probe	325
H4.2.4	Connector Holder	325
H4.2.5	Balun	325
H4.3	4.2 MHz Antenna Design	326
H4.4	Tuning of Activation Antenna	326
H4.5	Performance Check of Activation Antenna	326
H5	BALUNS	327

H5.1	General	327
H5.2	General Purpose Balun Design	327
H5.2.1	Overall Design	327
H5.2.2	Toroid	328
H5.3	Reference Loop Balun Design	328
H5.3.1	Overall Design	328
H5.3.2	Toroid	328
H5.4	Current Sense Balun Design	329
H5.4.1	Overall Design	329
H5.4.2	Toroid	329
H5.4.3	Current Probe	330
H5.5	Calibration of the Current Sense Balun	330
ANNEX I INTENSIONALLY DELETED		332
ANNEX J (INFORMATIVE), TEST TOOL FOR LZB CABLE TESTING		333
J1	GENERAL	333
J2	OVERALL DESIGNS	333
J2.1	General	333
J2.2	Vertical Loop used for 4.2 MHz Balise Tests	333
J2.3	Horizontal Loop used for 4.2 MHz On-board Equipment Tests	335
J2.4	Vertical Loop used for 27 MHz Tests	338
J3	PRINTED CIRCUIT BOARD AND COMPONENTS	340
J4	TUNING OF THE LZB LOOP	341

1 Introduction

This specification defines the specific set of verifications required for certification of conformity and suitability for use for all the Eurobalise data transmission products, as defined by UNISIG SUBSET-036.

These units are the Balises, (standing alone fixed data Balises, or controlled data Balises linked to the wayside signalling system) and the On-board Antenna Units integrated with the transmission functionality of the overall On-board ATP/ATC equipment.

The verifications dealt with in this specification are aimed at ensuring full and safe interoperability between wayside and On-board equipment of any supplier. For this purpose, this specification mostly addresses all those requirements that are specifically stated as mandatory in UNISIG SUBSET-036.

Some interesting non-mandatory requirements (defined as recommended, preferred, or optional solutions) are also considered in the annexes herein. This is for the purposes of supporting product interchangeability and maintainability.

The “Eurobalise” denomination can only identify those commercial products that have got certification of conformity compliance, based on the test requirements of this specification, by an officially recognised body.

This specification specifies detailed functional and non-functional test requirements for the Balise, identified as a basic wayside constituent of interoperability.

A special focus is given to the air-gap interface, where the Balise interacts with the On-board equipment. The air-gap requirements for the Balise have been defined in all needed details in UNISIG SUBSET-036.

The interface of the Balise with the wayside equipment is also considered, mainly for the purpose of interchangeability of wayside components.

This specification specifies a set of functional and non-functional test requirements for the transmission parts of the On-board equipment, which are deemed indispensable for the purpose of interoperability. Also in this case, a special focus is given to the air-gap interface, where the On-board Antenna Unit interacts with the wayside Balise.

Compared with the Balise case, only a minimum set of mandatory test requirements has been defined for the On-board equipment. This allows any kind of optimisation, in costs and performance, for the overall architecture of the On-board system, while still ensuring interoperability.

The specific test set-ups presented herein are recommendations only, and should primarily be regarded of principal nature. However, they are detailed enough to provide a solid basis for designing actual test set-ups, and they do include hints on important properties. Modifications are allowed as long the measurement accuracy is maintained, the same results are obtained, and the same properties are explored. There might in some cases be a need for additional precautions not to destroy specific instruments (due to high power levels).

2 Normative References

This specification incorporates, by dated or undated references, provisions from other publications. These normative references are cited at the appropriate places in the text, and the publications are listed hereafter. For dated references, subsequent amendments to, or revisions of, any of these publications apply to this specification only when incorporated herein by amendment or revision. For undated references, the latest edition of the publication referred to apply.

- I. UNISIG Specifications:
 - A. UNISIG SUBSET-036, FFFIS for Eurobalise
 - B. UNISIG SUBSET-023, Glossary of UNISIG Terms and Abbreviations

3 Terminology and Definitions

3.1 Acronyms and Abbreviations

In general, the acronyms and abbreviations of UNISIG SUBSET-036, and of UNISIG SUBSET-023, apply. The following list of additional acronyms applies within this specification:

Acronym	Explanation
APT	Antenna Positioning Tool
CS	Current Sense
DUT	Device Under Test
GUI	Graphical User Interface
ID	Identity
LRRT	Laboratory Reference Receiver Tool
LTMS	Laboratory Test and Measurement System
LTOM	Laboratory Time and Odometer Module
OLTG	Off-line Telegram Generator
PCB	Printed Circuit Board
RF	Radio Frequency
RSG	Reference Signal Generator
VSWR	Voltage Standing Wave Ratio

The following additional abbreviations apply:

Abbreviation	Explanation
Char	Character
Tel.	Telegram

3.2 Definitions

In general, the definitions of UNISIG SUBSET-036, and of UNISIG SUBSET-023, apply.

3.3 Influence of Tolerances

The general requirement stated in UNISIG SUBSET-036 regarding test tolerances should be observed. The requirements in the specification limits do not involve the error of the test equipment that is used in the test process, unless this is expressly written. This means that a maximum limit value shall be decreased, and a minimum limit value shall be increased with the applicable equipment error during test. Thus, the use of a very accurate test tool widens the allowed tolerances for the actual test object.

The number of digits, which the specific parameter values are expressed in, regarding the limits stated within UNISIG SUBSET-036 are not to be regarded as significant digits. The tolerances state the accuracy, and thus the significance of the digits. Thus, they (the expressed number of digits) do not imply a certain required accuracy or resolution. The required resolution and accuracy must be evaluated by other means. A general principle is that the accuracy/resolution of test tools should be in the order of 1 % (or possibly 5 %) of the specified tolerance range (if feasible), or better. Using better tools allow a wider tolerance range for the actual device under test (DUT). In some cases this high accuracy is not feasible (can not be achieved in a reasonable way), but the reason for this shall be explained/justified.

In this specification, calibration procedures and calibration set-ups are repeated in each test description. The spirit is neither that this reflects the sequence of the activities, nor that re-calibration is frequently required. The important thing is to calibrate when deemed necessary to achieve the required accuracy.

4 Tests of the Up-link Balise

4.1 Reference Test Configurations

4.1.1 General

The following conditions should apply for the majority of the tests where no specific environmental or operational condition is required.

Ambient temperature	25 °C ± 10 °C
Relative humidity	25 % to 75 %
Atmospheric Pressure	86 kPa to 106 kPa
Debris in the air-gap	None
Tele-powering mode	CW
EMC noise within the Up-link frequency band	Negligible

The environmental conditions of the table above should be maintained as far as reasonably possible. Monitoring of the conditions should apply if it can not be guaranteed that the limits are fulfilled.

In order to minimise the possible influence from the surrounding environment, there shall be a volume around the Antenna Unit and the Balise under test that is free from metallic objects. The minimum extent of this volume is defined in Figure 1. This volume is also referred to as “free space“ condition. The space below 0.4 m (but above 0.7 m) underneath the Balise shall not contain any solid metal planes, and only a few metallic supports are allowed within 0.7 m underneath the Balise.

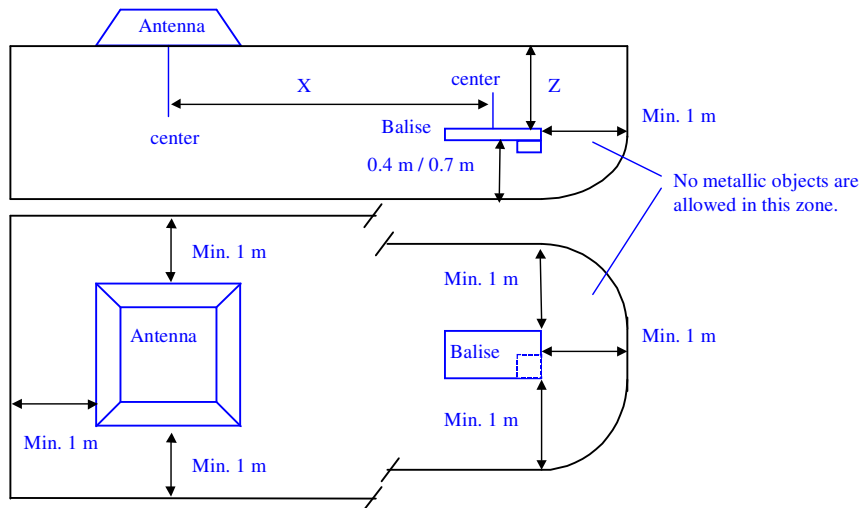

Figure 1: Definition of “free space” around the sub-system under test

4.1.2 Monitored Interfaces

The following interfaces are used:

- Interface 'A' (the air-gap interface).
- Interface 'C' (the Balise controlling interface).

4.1.3 Test Tools and Procedures

The following list summarises the herein-defined tests:

1. Verification of Interface 'A' (air-gap):
 - 1.1. Field conformity in the main lobe zone, and in the side-lobe zone, for the Tele-powering field received by the Balise;
 - 1.2. Field conformity in the main lobe zone, side lobe zone, and cross-talk protected zone, for the Up-link field generated by the Balise;
 - 1.3. Compliance of the electrical characteristics of the Up-link signal;
2. Verification of Balise controlling interface for controlled Balises:
 - 2.1. Up-link data signal characteristics at Interface 'C1';
 - 2.2. Biasing signal characteristics at Interface 'C6';
 - 2.3. Return Loss at the source end (LEU output) of Interfaces 'C1' and 'C6';
 - 2.4. Switching from Interface 'C1' telegram to the Default Telegram when an invalid signal is temporarily or permanently simulated at Interface 'C1';
 - 2.5. Blocking signal characteristics at Interface 'C4' (where applicable).
3. Verification of internal functionality:
 - 3.1. I/O characteristics;
 - 3.2. Balise impedance with respect to the Tele-powering source;
 - 3.3. Time delay between data at Interfaces 'C1' and 'A1' (controlled Balises only);
 - 3.4. Start-up behaviour of the Up-link signal;
 - 3.5. KER compatible response with a "non-toggling" Tele-powering signal.
4. Verification of cross-talk immunity with nearby cables (transversal cables according to the specific installation constraints given by the manufacturer).
5. Verification of the compliance with some specific EMC requirements.

The following tools are anticipated for the Balise tests:

- Test Management System, used for co-ordinating the measurements, controlling the other tools of the test set-up, and for logging and reporting the test results;
- Antenna Positioning Tool;
- Reference Loops (Standard or Reduced Size type) equipped with Baluns;
- Test and Activation Antennas;
- Reference Signal Generators;
- Telegram Generator;
- Reference Receiver;
- RF instruments and accessories of general use;
- Reference Units for debris, metallic masses, and cables.

4.2 Laboratory Tests

4.2.1 Generic Test and Calibration Set-up notes

The following aspects shall be respected for all test set-ups within this clause (clause 4). For some set-ups all aspects apply, but for others only some apply. The applicability is evident from the recommended test set-ups presented herein.

- A spectrum analyser or similar equipment may substitute any power meter. However, this device shall be calibrated against a power meter prior to the test.
- It shall be verified that all harmonics are suppressed by at least 40 dB if power meters are used. Otherwise, sufficient filtering shall be performed.
- All input and output ports of the devices in accordance with clause H3 on page 316 and H4 on page 322 shall be equipped with suitable baluns (these are part of the defined devices).
- The attenuators connected before and after the RF power amplifier shall be positioned as close as possible to the amplifier, and are used for ensuring good VSWR. The attenuator on the amplifier output is also used for protecting the amplifier from reflected power.
- It is important that all cabling is of low loss double shielded type (e.g., RG 214). Furthermore, the cables shall be “de-bugged” using suitable ferrite clamps, evenly spaced along the cables, at distances less than 70 cm. The core material in the ferrite clamps shall be “Amidon 43” or equivalent.
- The calibrations and tests shall be performed with Balise telegram of type 1 defined in clause A2 of Annex A on page 161, unless otherwise explicitly stated. The Balise, the Reference Loop and the “cable” (during cross-talk tests) shall transmit the same telegram.
- RMS values are applicable unless otherwise explicitly stated.
- Iron bars shall be at least 50 cm from metal objects like a concrete floor containing iron reinforcements.
- The cable carrying the 27 MHz signal to the Test Antenna (see clause H3 of Annex H on page 316) shall be identical throughout the entire test process.
- It is essential that the Reference Loops used during the tests fulfil the requirements of clause B2 of Annex B on page 168, and are characterised prior to testing. The procedure for characterisation of the equipment is defined by sub-clause B2.6 of Annex B on page 173.
- Ferrite devices shall be used in order to reduce the RF field effect on the measurements. A balun basically consists of a ferrite core (see clause H5 of Annex H on page 327 for more details). A balun shall be positioned at the end of the cable, i.e., at the Reference Loop connector, unless otherwise explicitly stated.
- All distances are in millimetres unless explicitly otherwise stated.
- The orientation of the Reduced Size Balise/Reference Loop is irrelevant unless otherwise explicitly stated. However, calibrations and measurements shall be performed with the same orientation.
- In case of testing with some debris conditions, please observe the increase of flux levels (when applicable) as defined in UNISIG SUBSET-036.

- In case of verifying characteristics at the upper extreme temperature, it is judged sufficient to perform testing with constant temperature only (without concurrent solar radiation). It is judged relevant that the maximum increase in temperature that would have been caused by the (non-existing) specified solar radiation level (see sub-clause 4.9 of EN 50125-3), in the worst Balise conditions, is 30 °C. This shall be considered when applying the requirements of UNISIG SUBSET-036, unless the manufacturer can provide evidence that a lower temperature increase applies.
- The defined installation case with metallic plane in the extreme vicinity of the Balise may require specifically tuned Balises (see UNISIG SUBSET-036). In such a case, the metallic plane is considered an integral part of the Balise. However, please observe that field conformity requirements apply to free air conditions.
- For specifically tuned Balises (with an integral metallic plane), the herein defined “Case 1” and “Case 2” metallic planes do not apply.
- In general, testing the condition with the metallic plane in the extreme vicinity of the Balise is optional and applies only to products stated to fulfil this specific installation condition.
- If not otherwise explicitly stated, the defined “Case 1” metallic plane condition applies for Balise testing (when metallic plane conditions apply).
- Applicable sources of data for controlled Balises versus test cases are clarified in sub-clause C7.3 on page 214.¹

¹ Sub-clause C7.3 does not introduce any new test cases relative to the previous version of this test specification. It merely clarifies the intent of the main text.

4.2.2 Up-link Field Conformity

4.2.2.1 General

This sub-clause defines the test procedure for Up-link field conformity testing. It also includes the various test set-ups that are recommended. The test procedures include two different steps with partially different test set-ups. The steps are:

- Calibration of 4.2 MHz Balise loop current I_{loop} .
- Balise conformity measurements.

There are two versions of the Test Antenna used in this test procedure. The first is the Standard Test Antenna, or simply Test Antenna. The second is the Modified Test Antenna. This device has no 27 MHz loop but is apart from this identical to the Standard Test Antenna. Both versions are described in clause H3 of Annex H on page 316.

There are also two versions of Activation Antennas. The first is the standard Activation Antenna with a 27 MHz loop. The second device is modified so that the 27 MHz loop is replaced by a 4.2 MHz loop. This device is only used as a measurement probe, and is identical to the Activation Antenna apart from the change of loops. This device is named 4.2 MHz Antenna. Both versions are described in clause H4 of Annex H on page 322.

The calibrations and tests shall be performed with a Balise telegram of type 1 defined in clause A2 of Annex A on page 161. Both the Balise and the Reference Loop shall transmit the same telegram. In all tests and calibrations with controlled Balise, telegrams transmitted via the Balise controlling interface shall be used (with nominal Balise controlling interface conditions).

Balise conformity measurements shall be performed during free air conditions only.

4.2.2.2 Calibration of 4.2 MHz Balise Loop Current in the Main Lobe Zone

4.2.2.2.1 Calibration Configuration

A proposed calibration set-up is shown in Figure 2 below. Clause F1 of Annex F on page 297 gives an example of suitable test equipment. Power Meter 2 shall be able to accurately measure signal levels down to -55 dBm. If Power Meter 2 is substituted by for instance a spectrum analyser, then the measurement bandwidth of this device shall be 1.2 MHz. The preamplifier, and the filter before it, shall be connected as close as possible to the Test Antenna. The filter after the preamplifier shall be connected as close as possible to the Power Meter 2. See also sub-clause 4.2.1 on page 23.

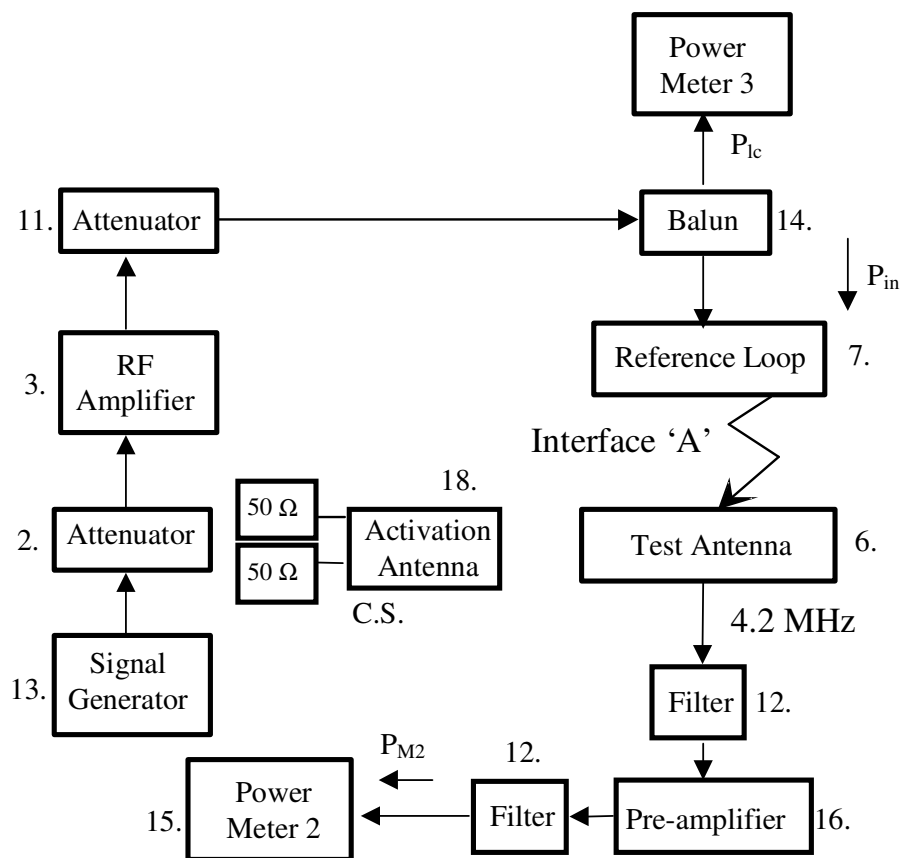

Figure 2: Test set-up for calibration of 4.2 MHz Balise Loop Current

4.2.2.2.2 Calibration Abstract

This calibration procedure will give a reference value P_{42RL} for each measurement point, defined in clause C1 of Annex C on page 205, which shall be compared with the corresponding value P_{42BA} for the Balise. The reference value P_{42RL} is reflecting the flux received by the Test Antenna, and measured by Power Meter 2 (P_{M2}) and then compensated, and called P_{42RL} . The calibration is performed with the current I_{u2}/B through the Reference Loop. The current through the Reference Loop is monitored by Power Meter 3 (P_{Ic}).

4.2.2.2.3 Calibration Procedure

1. Position the Modified Test Antenna (without 27 MHz loop) in position $[X = 0, Y = 0, Z = 220]$ relative to the Reference Loop. Be sure to position the electrical centre of the Test Antenna aligned with the electrical centre of the Reference Loop. Also check that the X, Y, and Z axes of the Reference Loop are correctly aligned to the X, Y, and Z axes of the positioning system. Position the Activation Antenna, in position $[X = 440, Y = 220, Z = 0]$ relative to the Reference Loop. This position shall be fixed during the calibration.
2. Set the Signal Generator to generate the FSK signal that carries telegram type 1.
3. Adjust the Signal Generator amplitude in order to achieve a current of approximately I_{u2}/B through the Reference Loop.
For calibration and compensation of the Current Sense Balun see clause H5 of Annex H on page 327.
Record the reading of Power Meter 3 and call it P_{Ic} .

Repeat
for each
position

4. Record the reading of Power Meter 2 (called P_{M2}) and Power Meter 3 (called P_{M3}).
5. Compensate the P_{M2} reading with the difference between the P_{M3} reading and the power level P_{Ic} , for I_{u2}/B measured in step 3. ² Call the new value P_{42RL} .

$$P_{42RL} = P_{M2} + (P_{Ic} - P_{M3}), \quad \text{all values in dBm.}$$

6. Perform steps 4 and 5 for all the $[X, Y, Z]$ positions listed in clause C1 of Annex C on page 205.

² The reason for this compensation is that the relative accuracy for the value of P_{42RL} between the different positions needs to be very good, and that this procedure compensates for power amplifier drift and impedance changes in the Reference Loop when moving the Test Antenna.

4.2.2.3 Balise Up-link Conformity Measurements in the Main Lobe Zone

4.2.2.3.1 Test Configuration

A proposed test set-up is shown in Figure 3 below. Clause F1 of Annex F on page 297 gives an example of suitable test equipment. Power Meter 3 shall be able to accurately measure signal levels down to -55 dBm. If Power Meter 3 is substituted, by for instance a spectrum analyser, then the measurement bandwidth of this device shall be 1.2 MHz. The preamplifier, and the filter before it, shall be connected as close as possible to the Test Antenna. The filter after the preamplifier shall be connected as close as possible to Power Meter 3. See also sub-clause 4.2.1 on page 23.

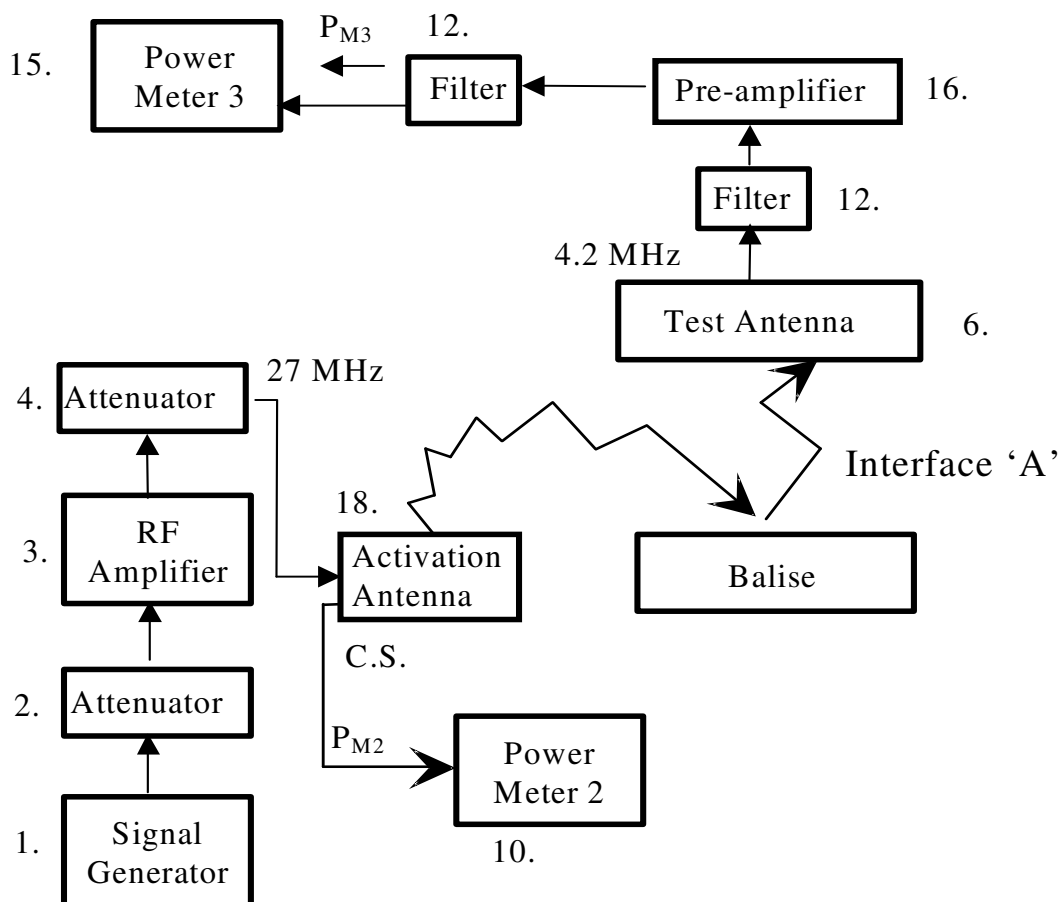

Figure 3: Test set-up for Balise Up-Link Conformity Measurements

4.2.2.3.2 Test Abstract

This measurement procedure will give a value P_{42BA} for each measurement point, defined in clause C1 of Annex C on page 205, which shall be compared with the corresponding reference value P_{42RL} for the Reference Loop measured in sub-clause 4.2.2.2.3 on page 27. The value P_{42BA} is reflecting the 4.2 MHz flux received by the Test Antenna, measured by Power Meter 3 (P_{M3}) and subsequently compensated as defined by the test procedure. The Balise is Tele-powered by an Activation Antenna with a 27 MHz flux that results in the corresponding Up-link Balise current I_{U2} .

4.2.2.3.3 Test Procedure

1. Position the Modified Test Antenna (without 27 MHz loop) in position $[X = 0, Y = 0, Z = 220]$ relative to the Balise. Be sure to position the electrical centre of the Test Antenna aligned with the centre of the Balise. Also check that the X, Y, and Z axes of the Balise are correctly aligned to the X, Y, and Z axes of the positioning system.

Position the Activation Antenna, in position $[X = 440, Y = 220, Z = 0]$ relative to the Balise. This position shall be fixed during the test.

2. Set the Signal Generator to the frequency 27.095 MHz, and to CW.
3. Adjust the Signal Generator amplitude in order to achieve a 4.2 MHz current in the Balise of approximately I_{U2} . This is accomplished by adjusting the Signal Generator until Power Meter 3 (P_{M3}) gives a reading equal to the value of P_{42RL} measured in sub-clause 4.2.2.2.3 on page 27 for position $[X = 0, Y = 0, Z = 220]$.

Record the reading of Power Meter 2, and call it P_{CS} .

Repeat
for each
position

4. Record the reading of Power Meter 2 (P_{M2}) and Power Meter 3 (P_{M3}).
5. Compensate the P_{M3} reading with the difference between the P_{M2} reading and the P_{CS} measured in step 3. Call the new value P_{42BA} .³

$$P_{42BA} = P_{M3} + (P_{CS} - P_{M2}), \text{ all values in dBm.}$$

6. Calculate the difference between P_{42BA} and P_{42RL} from sub-clause 4.2.2.2.3 on page 27, and call it P_{42DIFF} .

$$P_{42DIFF} = P_{42BA} - P_{42RL}$$

7. Perform steps 4, 5, and 6 for all the $[X, Y, Z]$ positions of the Test Antenna listed in clause C1 of Annex C on page 205. Note that the Activation Antenna position shall be fixed relative to the Balise.

³ The reason for this compensation is that the relative accuracy for the value of P_{42BA} , between the different positions, needs to be very good, and this procedure compensates for power amplifier drift and impedance changes in the Activation Antenna when moving the Test Antenna.

4.2.2.4 Evaluation of Up-link Conformity in the Main Lobe Zone

The results from the measurements in sub-clause 4.2.2.3.3 on page 29 (P_{42DIFF}) shall be compared with the requirements in UNISIG SUBSET-036 regarding conformity in the main lobe zone. The field generated by the Balise shall be compared with the “Reference Field”. The requirement stated in UNISIG SUBSET-036:

- For the field generated by the Balise ± 1.5 dB.

The value P_{42DIFF} reflects the absolute difference between the Reference Loop and the Balise. The requirement states the relative conformity. Therefore, the comparison with the requirement shall be relative.

The Balise is conform for the field generated by the Balise if:

The highest P_{42DIFF} - the lowest P_{42DIFF} is less than 3 dB

$$(P_{42DIFFMAX} - P_{42DIFFMIN}) < 3 \text{ dB}$$

4.2.2.5 Calibration of 4.2 MHz Balise Loop Current in the Side Lobe Zone

Use the same test set-up as in sub-clause 4.2.2.1 on page 26. The calibration procedure is the same as in sub-clause 4.2.2.3 on page 27 except for the geometrical test points. Perform the calibration procedure with the geometrical test points listed in clause C2 of Annex C on page 206.

4.2.2.6 Up-link Reference Field in the Side Lobe Zone

The output signal in the Side Lobe Zone for Up-link is defined in UNISIG SUBSET-036. The output signal from the Reference Loop is measured in sub-clause 4.2.2.5, and the result is a set of P_{42RL} values that shall be used to form a "Reference Field". This Reference Field gives the limits for the Balise output field strength in the Side Lobe Zone. The tolerances for conformity with the Reference Field, stated in UNISIG SUBSET-036, are +5 dB to $-\infty$. The Balise shall consequently give test results that show lower values than the Reference Field increased by 5 dB. The Reference Loop output shall also be translated +5 cm and -5 cm along the X and Y axes to form the Reference Field. See Figure 4 that shows a Reference Field in one quadrant. Similar curves shall be plotted for all quadrants. The Reference Field is the curve formed by the highest of:

- 35 dB below R0 (P_{42RL} value for position $[X = 0, Y = 0, Z = 220]$)
- Reference Loop output displaced -5 cm
- Reference Loop output
- Reference Loop output displaced +5 cm

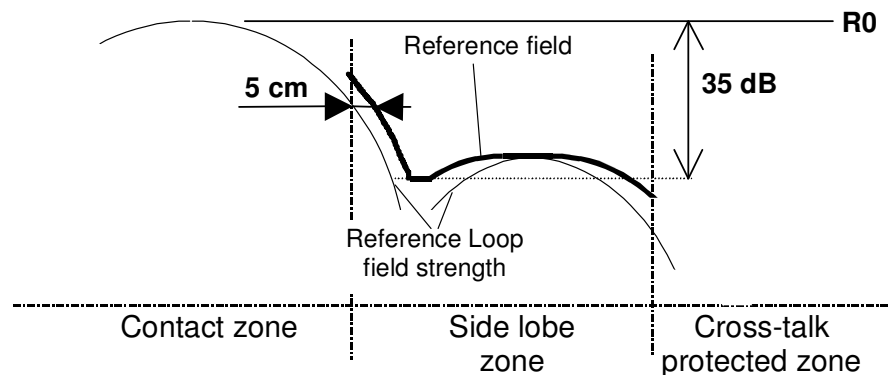

Figure 4 Up-link Reference Field in the Side Lobe Zone

The co-ordinates that shall be evaluated are:

- | | |
|-------------------------------------|---------------------------------------|
| $X = 250$ to $1300, Y = 0, Z = 220$ | $X = -250$ to $-1300, Y = 0, Z = 220$ |
| $X = 0, Y = 200$ to $1400, Z = 220$ | $X = 0, Y = -200$ to $-1400, Z = 220$ |

4.2.2.7 Balise Up-link Conformity Measurements in the Side Lobe Zone

Use the same test set-up as in sub-clause 4.2.2.3.1 on page 28. The test procedure is the same as in sub-clause 4.2.2.3.3 on page 29, except for the geometrical test points and that it is not needed to calculate the difference between P_{42RL} and P_{42BA} . Perform the test procedure with the geometrical test points listed in clause C2 of Annex C on page 206. Exclude the geometrical points: $[X = 200, Y = 0, Z = 220]$, $[X = -200, Y = 0, Z = 220]$, $[X = 0, Y = 150, Z = 220]$, and $[X = 0, Y = -150, Z = 220]$.

Plot the value P_{42BA} as a function of the position in four graphs, one for each quadrant.

4.2.2.8 Evaluation of Up-link Conformity in the Side Lobe Zone

UNISIG SUBSET-036 specifies that the Balise shall conform with the “Reference Field” in the Side Lobe Zone. The Reference Field for the Up-link is defined in UNISIG SUBSET-036, and recalled in sub-clause 4.2.2.6 on page 31. The result of the Balise measurements for the Up-link in sub-clause 4.2.2.7 on page 31 shall be compared with the Reference Field. The tolerances for conformity are stated in UNISIG SUBSET-036 to be from $-\infty$ to 5 dB above the Reference Field. See Figure 5.

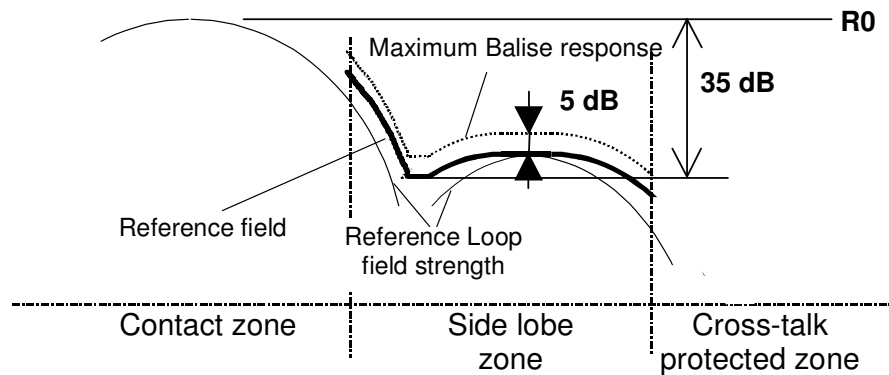

Figure 5: Maximum Balise response (4.2 MHz) in the Side Lobe Zone

4.2.2.9 Calibration of 4.2 MHz Balise Loop Current in the Cross-talk Protected Zone

4.2.2.9.1 Calibration Configuration

A proposed calibration set-up is shown in Figure 6 below. Clause F1 of Annex F on page 297 gives an example of suitable test equipment. A Reduced size Reference loop is used as field probe for these tests, instead of the Test Antenna, because of the very low field intensity to be measured. Power Meter 2 could alternatively be replaced by a narrow band measuring device, because it shall be able to accurately measure signal levels down to -75 dBm. In this case, the measurement bandwidth of this device shall be 1.2 MHz. See also sub-clause 4.2.1 on page 23.

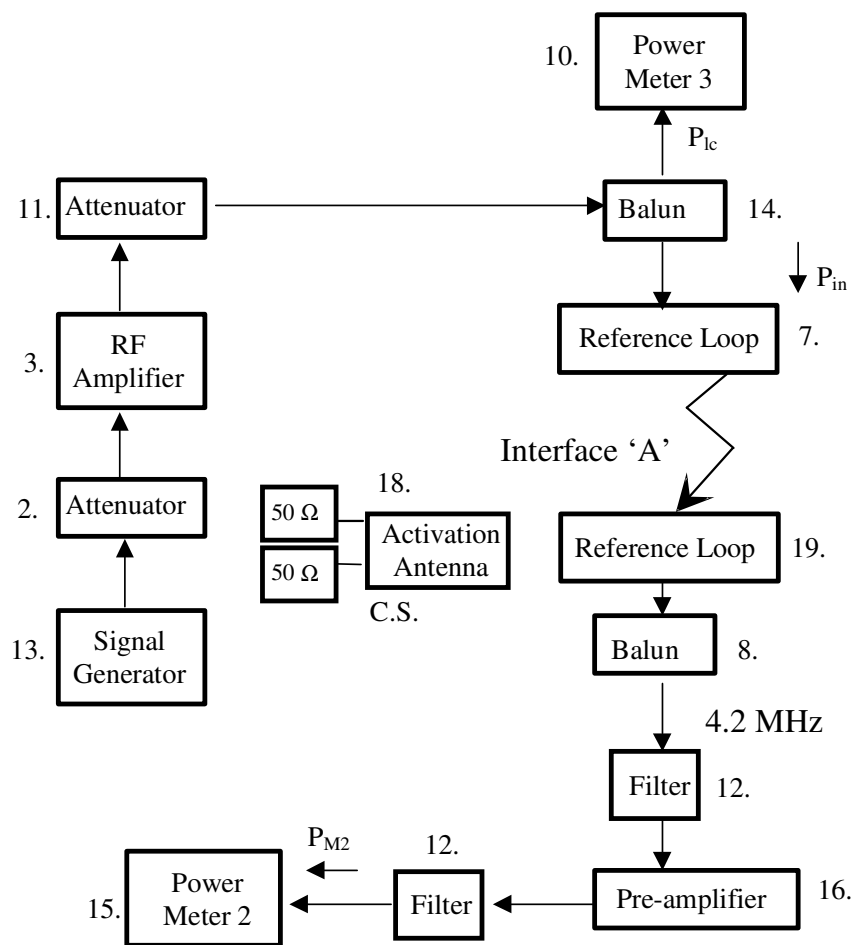

Figure 6: Test set-up for calibration of Up-link in the Cross-talk protected zone

4.2.2.9.2 Calibration Abstract

This calibration procedure will give a reference value P_{42RL} for each measurement point, defined in clause C3 of Annex C on page 207, which shall be used to define the Reference Field in the Cross-talk protected zone. The reference value P_{42RL} is reflecting the flux received by the Reduced Size Reference Loop, item 19, measured by Power Meter 2 (P_{M2}), and subsequently compensated and called P_{42RL} . The compensation is done to give corresponding values between measurements with a Test Antenna and a Reference Loop used as measuring devices. The calibration is performed with the current I_{02}/B through the transmitting Reference Loop (item 7). The current through the receiving Reference Loop (item 19) is monitored by Power Meter 3 (P_{1c}).

The orientation of the receiving Reference Loop is with its longest size parallel to the X axis. Locate the Activation Antenna in position $[X = 440, Y = 220, Z = 0]$ relative to the Reference Loop, item 7.

4.2.2.9.3 Calibration Procedure

1. Position the Reference Loop, item 19 (below called RL_probe), in the position $[X = 1000, Y = 0, Z = 220]$ relative to the Reference Loop. This position has previously been measured in the Side Lobe Zone and is only measured to refer the values measured with the RL_probe to the values previously measured with the Test Antenna. Be sure to position the electrical centre of the RL_probe aligned with respect to the electrical centre of the Reference Loop. Also check that the X, Y, and Z axes of the Reference Loop are correctly aligned to the X, Y, and Z axes of the positioning system.
2. Set the Signal Generator to generate an FSK signal that carries telegram type 1.
3. Adjust the Signal Generator amplitude in order to achieve a current of approximately I_{02}/B through the transmitting Reference Loop.
For calibration and compensation of the Current Sense Balun see clause H5 of Annex H on page 327. Record the reading of Power Meter 2 and call it P_{SB} . Calculate the difference between P_{SB} and the value P_{42RL} for position $[X = 1000, Y = 0, Z = 220]$ measured in sub-clause 4.2.2.5 on page 31. Call it P_{OFFSET} .

$$P_{OFFSET} = P_{SB} - P_{42RL} \text{ (measured in sub-clause 4.2.2.5)}$$

Repeat
for each
position

4. Record the reading of Power Meter 2 (called P_{M2}).
5. Compensate the P_{M2} reading with the offset value calculated in step 3.⁴ Call the new value P_{42RL} .

$$P_{42RL} = P_{M2} - P_{OFFSET}, \text{ all values in dBm.}$$

6. Perform 4 and 5 for all the $[X, Y, Z]$ positions listed in clause C3 of Annex C on page 207.
7. Position the RL_probe, in position $[X = 0, Y = 0, Z = 220]$ relative to the Reference Loop. Record the reading of Power Meter 2 and call it P_{RLREF} . This value is used in the Balise measurement below.

⁴ The reason for this compensation is that the value of P_{42RL} shall be compared with the corresponding values measured with the Test Antenna.

4.2.2.10 Up-link Reference Field in the Cross-talk Protected Zone

The output signal in the Cross-talk protected zone for Up-link is defined in UNISIG SUBSET-036. The output signal from the Reference Loop is measured in sub-clause 4.2.2.9, and the result is a set of P_{42RL} values that shall be used to form a “Reference Field”. This Reference Field gives the limits for the Balise output field strength in the Cross-talk protected zone. The tolerances for conformity with the Reference Field, stated in UNISIG SUBSET-036, are +5 dB to $-\infty$. The Balise shall consequently give test results that show lower values than the Reference Field increased by 5 dB. See Figure 7 that shows a Reference Field in one quadrant. Similar curves shall be plotted for all quadrants. The Reference Field is the curve formed by the highest of:

- 60 dB below R0 (P_{42RL} value for position [X = 0, Y = 0, Z = 220])
- Reference Loop field strength (measured in sub-clause 4.2.2.9)

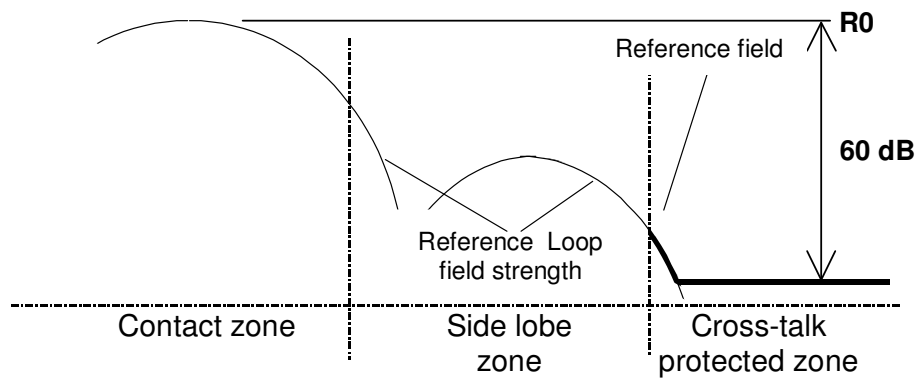

Figure 7: Up-link Reference Field in the Cross-talk protected zone

The co-ordinates that shall be evaluated are:

$$X = 1300 \text{ to } 3000, Y = 0, Z = 220$$

$$X = -1300 \text{ to } -3000, Y = 0, Z = 220$$

$$X = 0, Y = 1400 \text{ to } 3000, Z = 220$$

$$X = 0, Y = -1400 \text{ to } -3000, Z = 220$$

4.2.2.11 Balise Up-link Conformity Measurements in the Cross-talk Protected Zone

4.2.2.11.1 Test Configuration

A proposed test set-up is shown in Figure 8 below. Clause F1 of Annex F on page 297 gives an example of suitable test equipment. Power Meter 2 could alternatively be replaced by a narrow band measuring device, because it shall be able to accurately measure signal levels down to -75 dBm. In this case, the measurement bandwidth of this device shall be 1.2 MHz. See also sub-clause 4.2.1 on page 23.

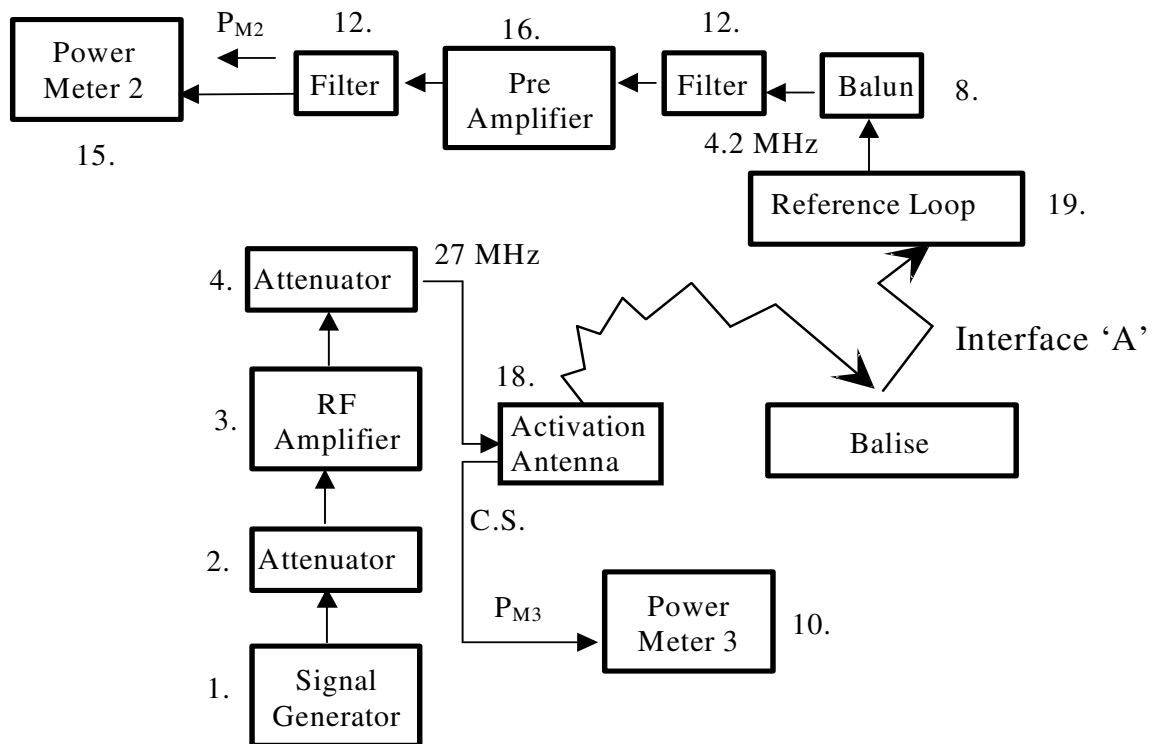

Figure 8: Test set-up for Balise measurement of Up-link in the Cross-talk protected zone

4.2.2.11.2 Test Abstract

This measurement procedure will give a value P_{42BA} for each measurement point, defined in clause C3 of Annex C on page 207, which shall be compared with the Reference Field defined in sub-clause 4.2.2.10. The value P_{42BA} is reflecting the 4.2 MHz flux received by the Reference Loop, item 19, measured by Power Meter 2 (P_{M2}) and subsequently compensated as defined by the test procedure. The compensation is performed to give corresponding values between measurements with a Test Antenna and a Reference Loop used as measuring devices. The Balise is Tele-powered by an Activation Antenna with a 27 MHz flux that results in the corresponding Up-link Balise current I_{u2} .

4.2.2.11.3 Test Procedure

1. Position the Reference Loop, item 19 (below called RL_probe), in position [X = 0, Y = 0, Z = 220] relative to the Balise. This position has previously been measured in sub-clause 4.2.2.9.3 on page 34, and is used for the adjustment of Balise current. Be sure to position the electrical centre of the RL_probe aligned with the electrical centre of the Balise. Also check that the X, Y, and Z axes of the Balise are correctly aligned to the X, Y, and Z axes of the positioning system. Position the Activation Antenna in position [X = 440, Y = 220, Z = 0] relative to the Balise. This position shall be fixed during the test.
 2. Set the Signal Generator to the frequency 27.095 MHz, and to CW.
 3. Adjust the Signal Generator amplitude in order to achieve a 4.2 MHz current in the Balise of approximately I_{U2} . This is accomplished by adjusting the Signal Generator until Power Meter 2 (P_{M2}) gives a reading equal to the value of P_{RLPREF} measured in sub-clause 4.2.2.9.3 on page 34 for position [X = 0, Y = 0, Z = 220].
 4. Position the RL_probe in the first position listed in clause C3 of Annex C on page 207.
- Repeat for each position {
5. Record the reading of Power Meter 2 (called P_{M2}).
 6. Compensate the P_{M2} reading with the offset value calculated in sub-clause 4.2.2.9.3 on page 34.
⁵ Call the new value P_{42BA} .

$$P_{42BA} = P_{M2} - P_{OFFSET}, \text{ all values in dBm.}$$
7. Perform 5 and 6 for all the [X, Y, Z] positions listed in clause C3 of Annex C on page 207. Note that the Activation Antenna position shall be fixed relative to the Balise.

4.2.2.12 Evaluation of Up-link Conformity in the Cross-talk Protected Zone

UNISIG SUBSET-036 specifies that the Balise shall conform with the “Reference Field” in the Cross-talk protected zone. The Reference Field for the Up-link is defined in UNISIG SUBSET-036 and recalled in sub-clause 4.2.2.10 on page 35. The result of the Balise measurements for the Up-link in sub-clause 4.2.2.11.3 on page 37 shall be compared with the Reference Field. The tolerances for conformity are stated in UNISIG SUBSET-036 to be from $-\infty$ to 5 dB above the Reference Field. See Figure 9.

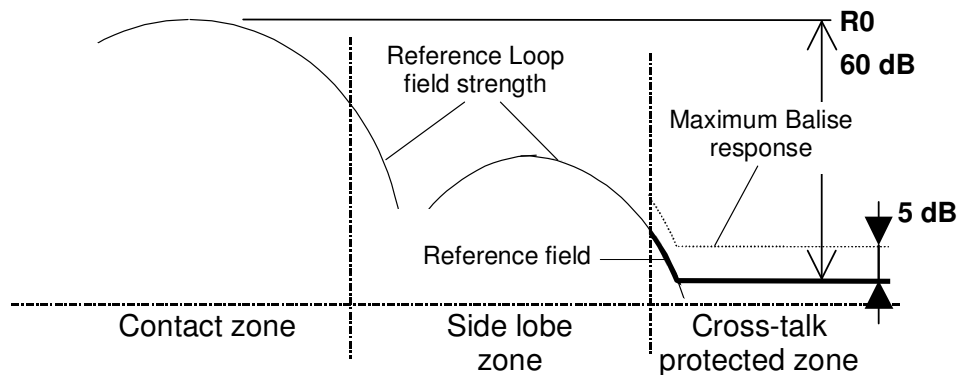

Figure 9 Maximum Balise response (4.2 MHz) in the Cross-talk protected zone

⁵ The reason for this compensation is that the value of P_{42BA} shall be compared with the corresponding values measured with the Test Antenna.

4.2.3 Tele-powering Field Conformity

4.2.3.1 General

This sub-clause defines the test procedure for Tele-powering flux conformity testing. It also includes the various test set-ups that are recommended. The test procedures include two different steps with partially different test set-ups. The steps are:

- Calibration of 27 MHz Tele-powering flux ϕ .
- Balise conformity measurements.

There are two versions of the Test Antenna used in this test procedure. The first is the Standard Test Antenna, or simply Test Antenna. The second is the Modified Test Antenna. This device has no 27 MHz loop but is apart from this identical to the Standard Test Antenna. Both versions are described in clause H3 of Annex H on page 316.

There are also two versions of Activation Antennas. The first is the standard Activation Antenna with a 27 MHz loop. The second device is modified so that the 27 MHz loop is replaced by a 4.2 MHz loop. This device is only used as a measurement probe, and is identical to the Activation Antenna apart from the change of loops. This device is named 4.2 MHz Antenna. Both versions are described in clause H4 of Annex H on page 322.

The calibrations and tests shall be performed with a Balise telegram of type 1 defined in clause A2 of Annex A on page 161. Both the Balise and the Reference Loop shall transmit the same telegram. In general, for all tests and calibrations with controlled Balise, telegrams transmitted via the Balise controlling interface shall be used (with nominal Balise controlling interface conditions). However, for free air conditions (but not other conditions), and in case of a controlled Balise, I/O Characteristics tests (see sub-clause 4.2.4 on page 47) shall be performed both when the telegram is sent through the Balise controlling interface, and from the internal default telegram.

Balise conformity measurements shall be performed during free air conditions only.

4.2.3.2.2 Calibration Abstract

This calibration procedure will give a reference value P_{27RL} for each measurement point, defined in clause C1 of Annex C on page 205, which shall be compared with the corresponding value P_{27BA} for the Balise. The reference value P_{27RL} is proportional to the square of the current needed for obtaining a flux level of ϕ_{d1} through the Reference Area. The current is measured by Power Meter 2 (P_{M2}), subsequently compensated, and called P_{27RL} .

The calibration procedure for one of the geometrical positions, $[X = 0, Y = 0, Z = 220]$, shall be performed also under other test conditions than free air, and without the 4.2 MHz Antenna. The result shall be used in sub-clause 4.2.4 on page 47. The following test conditions specified in clause B5 of Annex B on page 190 shall be used:

- | | |
|------------------|---|
| Debris: | Salt Water, debris class (A or B) defined by the manufacturer.
Clear Water, debris class (A or B) defined by the manufacturer.
Iron Ore (Magnetite), debris class (A or B) defined by the manufacturer. |
| Metallic object: | Metallic plate underneath the Balise, Case 1.
Steel Sleepers
Other Sleepers (mounting assemblies) |

4.2.3.2.3 Calibration Procedure

1. Position the (Standard) Test Antenna in position [x = 0, y = 0, z = 220] relative to the Reference Loop. Be sure to position the electrical centre of the Test Antenna aligned with the electrical centre of the Reference Loop. Also check that the X, Y, and Z axes of the Reference Loop are correctly aligned to the X, Y, and Z axes of the positioning system. Position the 4.2 MHz Antenna in position [X = 0, Y = 0, Z = 100] relative to the Reference Loop. This position shall be fixed during the test.
2. Determine a suitable power level, P_L , for a flux of ϕ_{d1} . The power, P_L , is determined by:

$$P_L = \frac{(2 \cdot \pi \cdot f \cdot \phi_{d1})^2}{50 \cdot \left(\frac{|50 + Z_{loop}|}{50} \right)^2 \cdot B^2}$$

where: $f = 27.095$ MHz
 $Z_{loop} = R_{loop} + j X_{loop} \Omega$ (actual impedance in the absence of any antenna)
 P_L = Power measured out of the Reference Loop [W]
 B = Reference Loop matching transfer ratio.

$$PM_3 = 10 \cdot \log(P_L \cdot 1000) - \text{Attenuation [dBm]}$$

where: *Attenuation* equals the attenuation of items 8 and 9 together with the cable from the Reference Loop to the power meter sensor head.⁶

Measure the *Attenuation* and calculate the value of P_{M3} . Call the calculated value P_{M3REF} .

3. Set the Signal Generator to the frequency 27.095 MHz, and to CW.

Repeat for each position	{	4. Adjust the input power to the Test Antenna in order to achieve approximately ϕ_{d1} through the Reference Loop. Record the reading of Power Meter 3 (called P_{M3}).
		5. Record the reading of Power Meter 2 (called P_{M2}).
		6. Compensate the P_{M2} reading with the difference between the P_{M3} reading and the power level P_{M3REF} calculated in step 2. ⁷ Call the new value P_{27RL} . $P_{27RL} = P_{M2} + (P_{M3REF} - P_{M3})$, all values in dBm.
7. Perform steps 4, 5, and 6 for all the [X, Y, Z] positions listed in clause C1 of Annex C on page 205.
8. Perform steps 4, 5, and 6 for the different test conditions specified in sub-clause 4.2.3.2.2 at position [X = 0, Y = 0, Z = 220].

⁶ Assuming that Z_{loop} is small compared to 50 Ω , $\phi_{d1}=7.7$ nVs, and that the *Attenuation* equals 20 dB, then the power level PM_3 will be -4.6 dBm for the Standard Size Reference Loop. For the Reduced Size Reference Loop, the corresponding value for $\phi_{d1}=4.9$ nVs is -8.6 dBm.

⁷ The reason for this compensation is that the relative accuracy for the value of P_{27RL} between the different positions needs to be very good, and this procedure compensates for signal generator adjustment error.

4.2.3.3 Balise Tele-powering Conformity Measurements in Main Lobe Zone

4.2.3.3.1 Test Configuration

A proposed test set-up is shown in Figure 11 below. Clause F1 of Annex F on page 297 gives an example of suitable test equipment. See also sub-clause 4.2.1 on page 23.

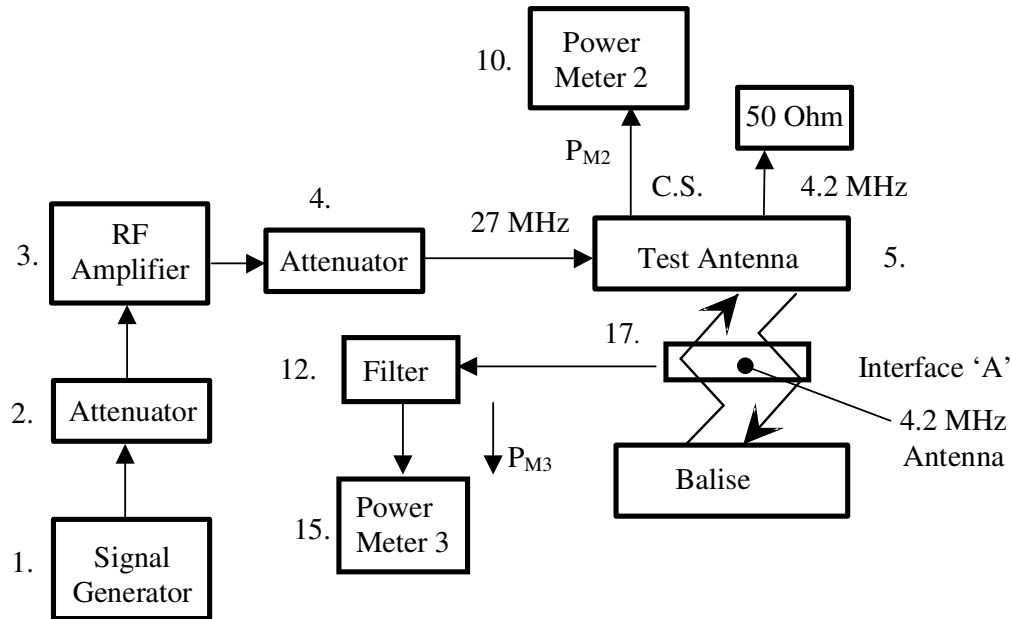

Figure 11: Test set-up for Balise conformity Tele-powering

4.2.3.3.2 Test Abstract

This measurement procedure will give a value P_{27BA} for each measurement point, defined in clause C1 of Annex C on page 205, which shall be compared with the corresponding reference value P_{27RL} for the Reference Loop measured in sub-clause 4.2.3.2.3 on page 41. The value P_{27BA} is proportional to the square of the 27 MHz current needed for obtaining a flux level of ϕ_{d1} through the Balise. The current is measured with Power Meter 2 (P_{M2}), compensated, and called P_{27BA} .

To find out when the Balise receives a flux of ϕ_{d1} the Balise response is measured with a fixed 4.2 MHz Antenna. In the first measurement position the 4.2 MHz response is measured with the same 27 MHz current that in the Test Antenna gave a flux of ϕ_{d1} through the Reference Loop. For each new position of the Test Antenna the 27 MHz power in the Test Antenna is adjusted to give a 4.2 MHz response that is equal to the first measurement position.

It is allowed to modify the ϕ_{d1} test level so that it is ensured that the Balise is operating in a linear region (at least ± 1.5 dB wide) suitable for the test. In case there is no such region, a smaller region can be selected individually for each position.

4.2.3.3.3 Test Procedure

1. Position the Standard Test Antenna in position [X = 0, Y = 0, Z = 220] relative to the Balise. Be sure to position the electrical centre of the Test Antenna aligned with the centre of the Balise. Also check that the X, Y, and Z axes of the Balise are correctly aligned to the X, Y, and Z axes of the positioning system.

Position the 4.2 MHz Antenna in position [X = 0, Y = 0, Z = 100] relative to the Balise. This position shall be fixed during the test.

2. Set the Signal Generator to the frequency 27.095 MHz, and to CW.
3. Verify if hysteresis effects exist by the following procedure:

Increase the power from zero until Power Meter 2 reads P_{27RL} for position [X = 0, Y = 0, Z = 460] measured in sub-clause 4.2.3.2.3 on page 41. Observe Power Meter 3 reading. Increase the power until Power Meter 2 reads 3 dB more. Decrease the power back again. Check that Power Meter 3 reads the same value as before the increase of power.

If hysteresis exists, the power adjustments below shall either start from zero for each new point, or the related uncertainty must be included in the measurement inaccuracy if not starting from zero.

4. Adjust the input power to the Test Antenna in order to achieve the chosen value of the reference flux through the Balise. This adjustment can be stopped when a linear region around the reference flux level is reached. This is accomplished when the reading of Power Meter 2 is equal to P_{27RL} for position [X = 0, Y = 0, Z = 220] measured in sub-clause 4.2.3.2.3 on page 41.

Record the reading of Power Meter 3, and call it P_{42} .

Repeat
for each
position

5. Adjust the input power to the Test Antenna in order to achieve a Power Meter 3 reading equal to P_{42} .
6. Record the reading of Power Meter 2 and Power Meter 3. Compensate the P_{M2} reading with the difference between the P_{M3} reading and the power level P_{42} recorded in step 4.⁸ Call the new value P_{27BA} .
7. Calculate the difference between P_{27BA} and P_{27RL} from sub-clause 4.2.3.2.3 on page 41, and call it P_{27DIFF} .

$$P_{27BA} = P_{M2} + (P_{42} - P_{M3}) \quad \text{all values in dBm.}$$

$$P_{27DIFF} = P_{27BA} - P_{27RL}$$

8. Perform steps 5, 6, and 7 for all the [X, Y, Z] positions of the Test Antenna listed in clause C1 of Annex C on page 205. Note that the 4.2 MHz Antenna position shall be fixed relative to the Balise.

⁸ The reason for this compensation is that the relative accuracy for the value of P_{27BA} between the different positions needs to be very good, and this procedure compensates for signal generator adjustment error.

4.2.3.4 Evaluation of Tele-powering Conformity in the Main Lobe Zone

The results from the measurements in sub-clause 4.2.3.3.3 on page 43 ($P_{27\text{DIFF}}$) shall be compared with the requirements in UNISIG SUBSET-036 regarding conformity in the main lobe zone. The field received by the Balise shall be compared with the “Reference Field”. The requirement stated in UNISIG SUBSET-036 is:

- For the field received by the Balise ± 1.5 dB.

The measurement errors shall be subtracted from the requirements before the comparison with the requirements. The value $P_{27\text{DIFF}}$ reflects the absolute difference between the Reference Loop and the Balise. The requirement states the relative conformity. Therefore, the comparison with the requirement shall be relative.

The Balise is conform for the field received by the Balise if:

The highest $P_{27\text{DIFF}}$ - the lowest $P_{27\text{DIFF}}$ is less than 3 dB

$$(P_{27\text{DIFFMAX}} - P_{27\text{DIFFMIN}}) < 3 \text{ dB}$$

4.2.3.5 Calibration of 27 MHz Tele-powering flux in the Side Lobe Zone

Use the same test set-up as in sub-clause 4.2.3.2.1 on page 39. The calibration procedure is the same as in sub-clause 4.2.3.2.3 on page 41, except for the geometrical test points. Perform the calibration procedure with the geometrical test points listed in clause C2 of Annex C on page 206.

The calibration measurements shall be limited to a maximum Tele-powering signal level of the reference value R_0 in Figure 12 below, augmented by 35 dB (in the notch and in the most extreme regions of the side-lobe zone). During this specific test, it is allowed that the input power to a Test Antenna implemented in accordance with clause H3 on page 316 is increased to a maximum level resulting in a current sense output of 15 dBm.

4.2.3.6 Tele-powering Reference Field in the Side Lobe Zone

The input signal in the Side Lobe Zone for Tele-powering is defined in UNISIG SUBSET-036 to have the same tolerances as for the Up-link. The input signal response is reflected by the current needed in a Test Antenna to give a flux of ϕ_{d1} in the Reference Loop / Balise. In sub-clause 4.2.3.5 the current is measured in the Side Lobe Zone and the result is a set of P_{27RL} values that shall be used to form a "Reference Field". This Reference Field gives the limits for the Balise response of Tele-powering flux in the Side Lobe Zone. The tolerances for conformity with the Reference Field, stated in UNISIG SUBSET-036, are -5 dB to $+\infty$. The Balise shall consequently give test results that show higher values, than the Reference Field lowered by 5 dB, or considered acceptable if the Balise has not started transmitting at the Reference Field level lowered by 5 dB (caused by test tool limitations). The Reference Loop response shall also be translated $+5$ cm and -5 cm along the X and Y axes to form the Reference Field. See Figure 12 that shows a Reference Field in one quadrant. Similar curves shall be plotted for all quadrants. The Reference Field is the curve formed by the lowest of:

- 35 dB above R_0 (P_{27RL} value for position $[X = 0, Y = 0, Z = 220]$)
- Reference Loop response displaced -5 cm
- Reference Loop response
- Reference Loop response displaced $+5$ cm

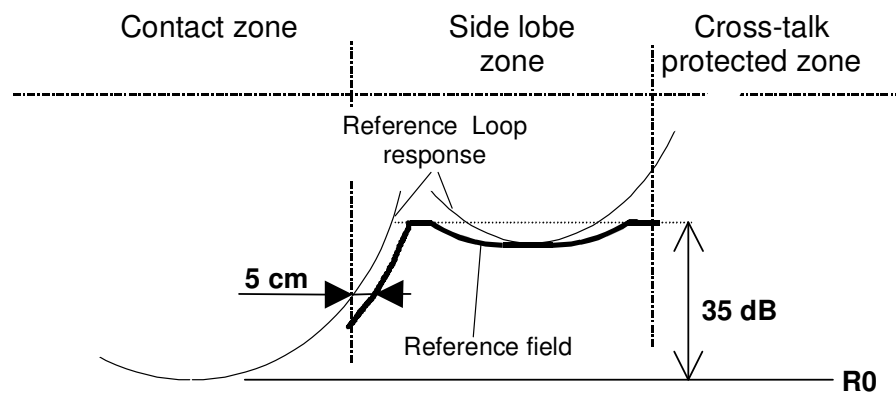

Figure 12: Tele-powering Reference Field in the Side Lobe Zone

The co-ordinates that shall be evaluated are:

- | | |
|---|---|
| $X = 250$ to 1300 , $Y = 0$, $Z = 220$ | $X = -250$ to -1300 , $Y = 0$, $Z = 220$ |
| $X = 0$, $Y = 200$ to 1400 , $Z = 220$ | $X = 0$, $Y = -200$ to -1400 , $Z = 220$ |

4.2.3.7 Balise Tele-powering Conformity Measurements in the Side Lobe Zone

Use the same test set-up as in sub-clause 4.2.3.3.1 on page 42. The test procedure is the same as in sub-clause 4.2.3.3.3 on page 43, except for the geometrical test points, and that it is not needed to calculate the difference between P_{27RL} and P_{27BA} . Perform the test procedure with the geometrical test points listed in clause C2 of Annex C on page 206. Exclude the geometrical points: $[X = 200, Y = 0, Z = 220]$, $[X = -200, Y = 0, Z = 220]$, $[X = 0, Y = 150, Z = 220]$, and $[X = 0, Y = -150, Z = 220]$.

Plot the value P_{27BA} as a function of the position in four graphs, one for each quadrant.

Please observe the limitations of the test tool expressed in sub-clause 4.2.3.6.

4.2.3.8 Evaluation of Tele-powering Conformity in the Side Lobe Zone

UNISIG SUBSET-036 specifies that the Balise shall conform with the “Reference Field” in the Side Lobe Zone. The Reference Field for the Tele-powering is defined in UNISIG SUBSET-036 and recalled in sub-clause 4.2.3.6 on page 45. The result of the Balise measurements for the Tele-powering in sub-clause 4.2.3.7 on page 46 shall be compared with the Reference Field. The tolerances for conformity are stated in UNISIG SUBSET-036 to be the same as for the Up-link, which means that the 27 MHz field needed to power the Balise may be from 5 dB below the Reference Field up to ∞ . See Figure 13

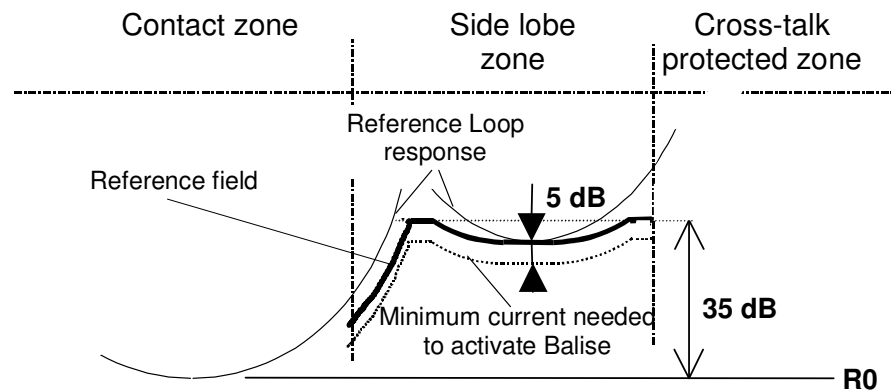

Figure 13: Minimum current (27 MHz) needed to activate the Balise in the Side Lobe Zone

4.2.4 I/O Characteristics

4.2.4.1 General

This sub-clause defines the test procedure for Input to Output Characteristics testing. It also includes the various test set-ups that are recommended.

In case of a controlled Balise, it shall be checked that the Balise shows the same behaviour both when the telegram is sent through the Balise controlling interface, and from the internal default telegram. This check shall be performed in free air, and with nominal Balise controlling interface conditions as defined by sub-clause 4.2.8.3 on page 91. In all other tests with controlled Balise, telegrams transmitted via the Balise controlling interface shall be used (with nominal Balise controlling interface conditions).

Hysteresis effects shall be considered when testing the Balise I/O characteristics.

I/O Characteristics measurements shall be performed during free air conditions, and in the presence of a defined amount of debris and metallic objects.

When testing the Water Class A debris case, adequate protection shall be added to the Test Antenna in order to avoid immersion of the loop element into water. This protection shall not alter the electrical characteristics of the Test Antenna. See sub-clause H3.2.1 on page 317.

Amplification of Up-link signals received by the Test Antenna, and/or the use of additional filters is allowed if improved accuracy is deemed necessary. If applicable, this shall be considered in calibrations as well as during measurements, it shall be stable, and it shall not affect general performance such as bandwidth etc.

4.2.4.2 Calibration of 4.2 MHz for Balise Input to Output Characteristics

4.2.4.2.1 Calibration Configuration

A proposed calibration set-up is shown in Figure 14 below. Clause F1 of Annex F on page 297 gives an example of suitable test equipment. If Power Meter 2 is substituted, by for instance a spectrum analyser, then the measurement bandwidth of this device shall be 1.2 MHz. The Test Antenna (item 5) and the cable from the Test Antenna to Power Meter 1 (the sensor head), shall be the same as in the calibration procedure in sub-clause 4.2.3.2 on page 39. See also sub-clause 4.2.1 on page 23.

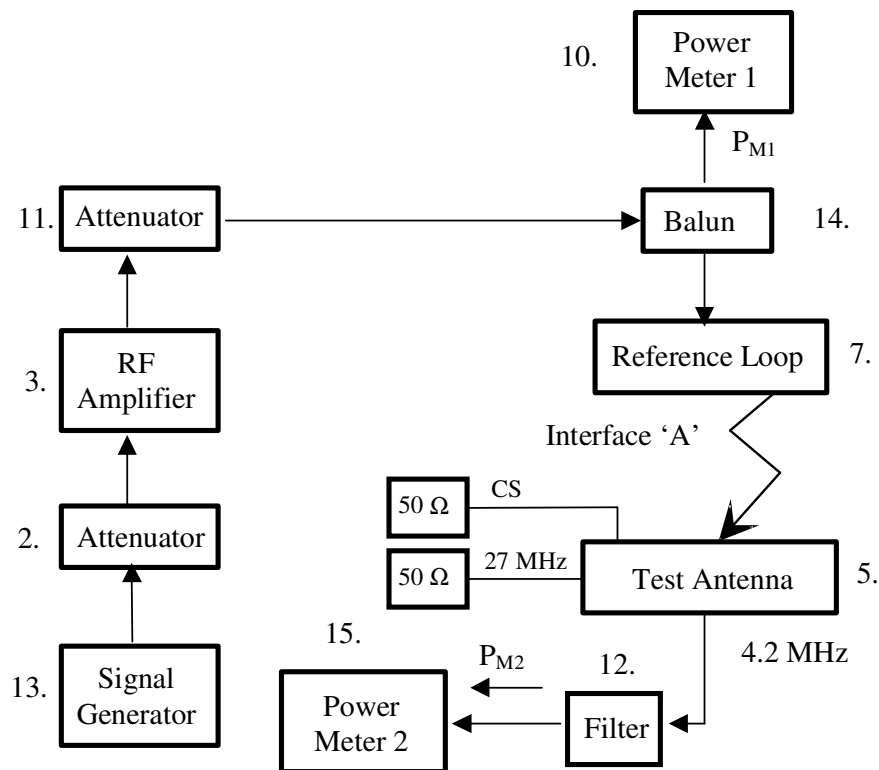

Figure 14: Test set-up for calibration of 4.2 MHz Balise Loop Current

4.2.4.2.2 Calibration Abstract

This calibration procedure will give a reference value P_{42RL} used in sub-clause 4.2.4.3 on page 50. The reference value P_{42RL} is reflecting the flux received by the Test Antenna, measured by Power Meter 2 (P_{M2}). The calibration is performed with the current I_{u2}/B through the Reference Loop. The current through the Reference Loop is monitored by Power Meter 1 (P_{M1}). The calibration procedure shall be performed also under other test conditions than free air. The following test conditions specified in clause B5 of Annex B on page 190 shall be used:

- | | |
|------------------|---|
| Debris: | Salt Water, debris class (A or B) defined by the manufacturer.
Clear Water, debris class (A or B) defined by the manufacturer.
Iron Ore (Magnetite), debris class (A or B) defined by the manufacturer. |
| Metallic object: | Metallic plate underneath the Balise, Case 1.
Steel Sleepers
Other Sleepers (mounting assemblies) |

4.2.4.2.3 Calibration Procedure

1. Position the Standard Test Antenna in position $[X = 0, Y = 0, Z = 220]$ relative to the Reference Loop. Be sure to position the electrical centre of the Test Antenna aligned with the electrical centre of the Reference Loop. Also check that the X, Y, and Z axes of the Reference Loop are correctly aligned to the X, Y, and Z axes of the positioning system.
2. Set the Signal Generator to generate the FSK signal that carries telegram type 1.
3. Calculate the exact power level P_{lc} that gives I_{u2}/B in the Reference Loop. For calibration and compensation of the Current Sense Balun see clause H5 of Annex H on page 327.
4. Adjust the Signal Generator amplitude in order to achieve a current of approximately I_{u2}/B through the Reference Loop, measured by Power Meter 1.
5. Record the reading of Power Meter 1 (called P_{M1}) and Power Meter 2 (called P_{M2}).
6. Compensate the P_{M2} reading with the difference between the P_{M1} reading and the exact power level, P_{lc} for I_{u2}/B , from the Current Sense Balun calibration in step 3.⁹ Call the new value P_{42RL} .

$$P_{42RL} = P_{M2} + (P_{lc} - P_{M1}) \quad \text{all values in dBm.}$$

The calibration procedure (steps 4 through 6) shall be repeated for the test conditions defined in sub-clause 4.2.4.2.2.

⁹ The reason for this compensation is that the absolute accuracy for the value of P_{42RL} needs to be good, and this procedure compensates for power amplifier drift and adjustment errors.

4.2.4.3 Balise Input to Output Characteristics Measurements

4.2.4.3.1 Test Configuration

A proposed test set-up is shown in Figure 15 below. Clause F1 of Annex F on page 297 gives an example of suitable test equipment. If Power Meter 2 is substituted, by for instance a spectrum analyser, then the measurement bandwidth of this device shall be 1.2 MHz. The filter (item 12), the Test Antenna (item 5) and the 4.2 MHz cables from the Test Antenna to the measurement point (i.e., the sensor head), shall be the same as in the calibration procedure in sub-clause 4.2.4.2 on page 48. See also sub-clause 4.2.1 on page 23.

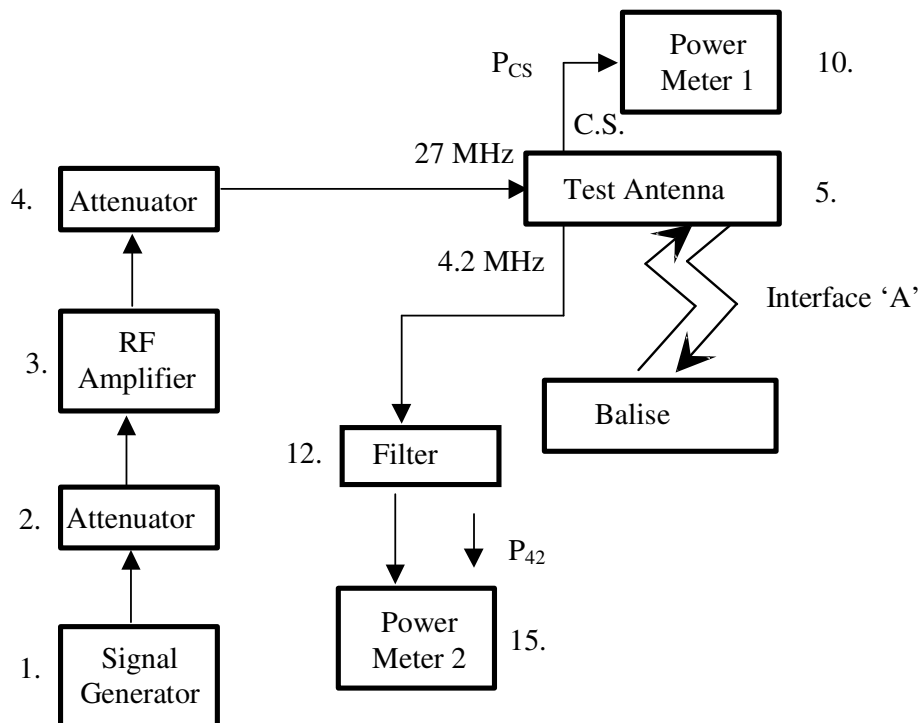

Figure 15: Test set-up for Input to Output Characteristics Measurements

Please observe that it needs to be verified that 27 MHz suppression in Up-link signal measurements is sufficient for achievement of the required accuracy. If not, additional filtering must be introduced (e.g., several filters in cascade).

4.2.4.3.2 Test Abstract

This measurement procedure will result in curves of the Balise response, which shall be compared with the requirement in UNISIG SUBSET-036. The Balise response is measured for both increasing and decreasing Tele-powering flux levels. A (Standard) Test Antenna is used to generate the 27 MHz flux from below ϕ_{d1} , up to ϕ_{d4} , and back down below ϕ_{d1} again. The flux is proportional to the current in the Test Antenna and reflected by Power Meter 1. The 4.2 MHz response is measured with the Test Antenna and Power Meter 2. The corresponding 4.2 MHz current in the Balise is calculated and plotted. The Test procedure shall be performed in free air and for the following test conditions specified in clause B5 of Annex B on page 190 ¹⁰:

- | | |
|------------------|---|
| Debris: | Salt Water, debris class (A or B) defined by the manufacturer.
Clear Water, debris class (A or B) defined by the manufacturer.
Iron Ore (Magnetite), debris class (A or B) defined by the manufacturer. |
| Metallic object: | Metallic plate underneath the Balise, Case 1.
Steel Sleepers
Other Sleepers (mounting assemblies) |

¹⁰ Testing in the presence of the LZB loop cable is judged not relevant since the resulting impact on the I/O characteristic itself is negligible compared with the other test conditions specified in this sub-clause. However, there are other critical mechanisms related to an LZB cable carrying undesired currents. This is detailed in sub-clause 4.2.5.5 on page 63.

4.2.4.3.3 Test Procedure

- Determine suitable P_{CS} power levels relevant for transfer characteristic measurements. The measurement shall be performed for the Test Antenna position [$X = 0, Y = 0, Z = 220$]. Use the measured value P_{27RL} for the above position, and the actual test condition from sub-clause 4.2.3.2.3 on page 41 as reference for the Φ_{d1} Tele-powering flux level. The table below gives the P_{CS} offset values to be used for the 27 MHz flux levels. The measurements shall start with the lowest flux, and with increasing flux reach Φ_{d4} , then the flux shall be decreased again to the lowest flux in the table. This procedure will also show if the Balise response has hysteresis.

Flux	Φ_{d1}				Φ_{d2}								Φ_{d4}	
P_{CS} offset	-3 dB	-1 dB	0 dB	+1 dB	+2 dB	+3 dB	+4 dB	+5 dB	+6 dB	+9 dB	+12 dB	+18 dB	+24 dB	Φ_{d4}

- Set the Signal Generator to the frequency 27.095 MHz, and to CW.
- Position the Test Antenna in position [$X = 0, Y = 0, Z = 220$] relative to the Balise.
- Adjust the Signal Generator amplitude in order to achieve a P_{CS} reading that corresponds to the sum of present P_{CS} offset and P_{27RL} . Record the exact P_{CS} reading.
- Record the 4.2 MHz power level P_{42} .
- Calculate the flux Φ , and the Balise loop current I_{loop} using:

$$\Phi = 10^{((P_{CS} - P_{27RL}) \div 20)} \times \Phi_{d1} \quad [\text{nVs}]$$

$$I_{loop} = 10^{((P_{42} - P_{42RL}) \div 20)} \times I_{U2} \quad [\text{mA}]$$

Where P_{42RL} is the calibration power, for the position [$X = 0, Y = 0, Z = 220$], and the actual test condition, achieved from Sub-clause 4.2.4.2.3 on page 49.

- With increasing flux, repeat steps 4, 5, and 6 for all flux levels.
- With decreasing flux, repeat steps 4, 5, and 6 for all flux levels.
- Plot I_{loop} as a function of Φ for both increasing flux and decreasing flux.

The test procedure (steps 1 through 9) shall be repeated for the test conditions defined in sub-clause 4.2.4.3.2.

4.2.4.4 Evaluation of I/O Characteristics

UNISIG SUBSET-036 specifies that the Balise response shall be inside the area limited by the shaded areas in Figure 16, and considering the measurement errors. Furthermore, the Balise response shall be inside this area for all the geometrical positions of the main lobe zone considering the actual Balise conformity performance. The latter requirement means that the upper restriction shall be further limited by the difference between the actual Balise conformity tolerance for the geometrical test point in question, and the worst case maximum Balise conformity deviation for any geometrical point. Similarly, the lower restriction shall be further limited by the difference between the actual Balise conformity tolerance for the geometrical test point in question, and the worst case minimum Balise conformity deviation for any geometrical point.

In other words, A, B, C, and D used in the equations below shall be expressed according to:

$$\begin{aligned}
A &= P_{42\text{DIFFMAX}} - P_{42\text{DIFF}} \\
B &= P_{42\text{DIFF}} - P_{42\text{DIFFMIN}} \\
C &= P_{27\text{DIFF}} - P_{42\text{DIFF}} + \max\{P_{42\text{DIFF}i} - P_{27\text{DIFF}i}\} \\
D &= P_{27\text{DIFFMAX}} - P_{27\text{DIFF}}
\end{aligned}$$

where $P_{27\text{DIFF}}$ and $P_{42\text{DIFF}}$ are the Balise conformity deviations in the actual geometrical test point (in this case $[X = 0, Y = 0, Z = 220]$). $P_{27\text{DIFFMAX}}$, $P_{27\text{DIFFMIN}}$, $P_{42\text{DIFFMAX}}$, and $P_{42\text{DIFFMIN}}$ are worst case Balise conformity deviations evaluated in sub-clause 4.2.2.4 on page 30. The difference $P_{42\text{DIFF}i} - P_{27\text{DIFF}i}$ is the difference of the conformity deviations for Up-link and Tele-powering for each individual geometrical test point (index i). The maximum of this difference for all geometrical test points shall be evaluated and considered regarding the constant C above. The reason is that the border of the shaded area is not a horizontal or vertical line for this region.

Please observe that A, B, C, and D above are expressed in dB.

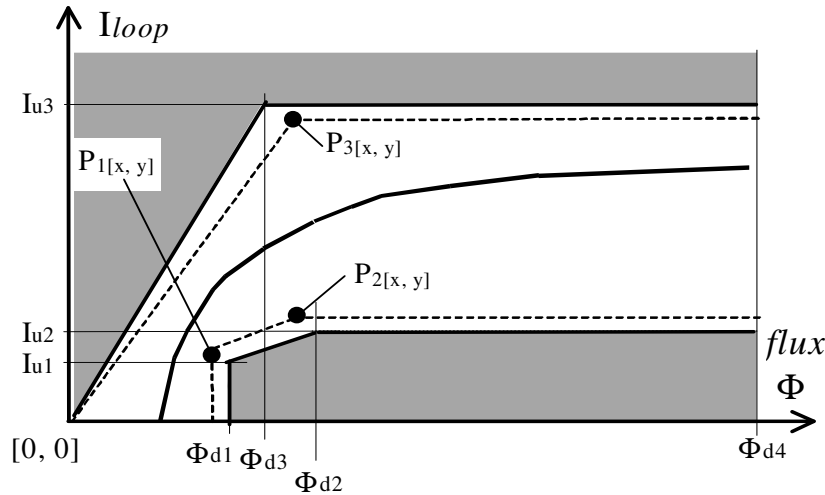

Figure 16: Input-to output transfer characteristics for a Balise

The co-ordinates of the points P_1 , P_2 , and P_3 respectively are:

- $P_{1[x, y]} = [\phi_{d1} 10^{-D/20}, I_{u1} 10^{B/20}]$
- $P_{2[x, y]} = [\phi_{d2} 10^{-D/20}, I_{u2} 10^{B/20}]$
- $P_{3[x, y]} = [\phi_{d3} 10^{C/20}, I_{u3} 10^{-A/20}]$

UNISIG SUBSET-036 also specifies that the response may not decrease more than 0.5 [dB/dB] with increasing flux values when the Balise is operating in saturated mode (i.e., when the flux through the reference area of the Balise is high). The values for I_{u1} , I_{u2} , I_{u3} , ϕ_{d1} , ϕ_{d2} , ϕ_{d3} , and ϕ_{d4} are found in UNISIG SUBSET-036.

4.2.5 Cross-talk Immunity with Cables

4.2.5.1 General

This sub-clause defines measurement methods for verifying potential cable related cross talk for the Balise.

It includes the test set-up that is required. For the Test set-up two calibrations are needed. One to calibrate the Activation Antenna to give a Tele-powering flux equal to $\phi_{d4} -6$ dB, and one to find out how much 4.2 MHz current that flows in the Balise when it receives that flux.

4.2.5.2 Calibration of 27 MHz Tele-powering flux

4.2.5.2.1 Calibration Configuration

A proposed calibration set-up is shown in Figure 17 below. Clause F1 of Annex F on page 297 gives an example of suitable test equipment. See also sub-clause 4.2.1 on page 23.

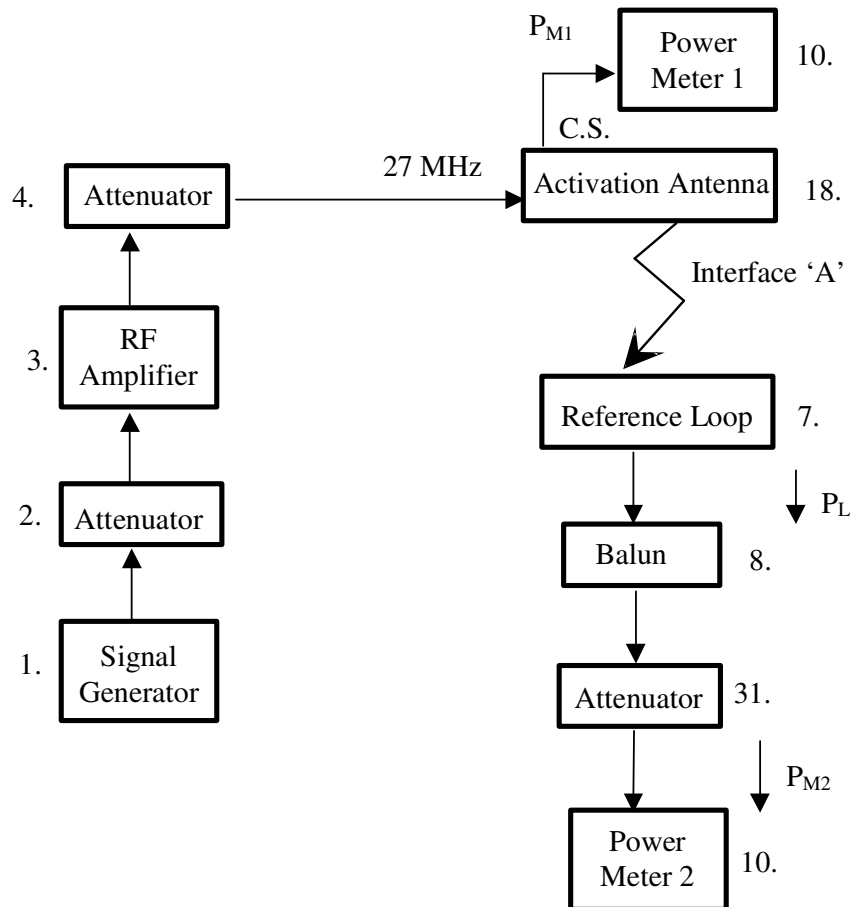

Figure 17: Test set-up for calibration of 27 MHz Tele-powering flux

4.2.5.2.2 Calibration Abstract

This calibration procedure will give a reference value P_{27AA} . The reference value P_{27AA} is used when activating the Balise with a flux level of $\phi_{d4} -6$ dB through the Reference Area.

4.2.5.2.3 Calibration Procedure

1. Position the Activation Antenna in position [$X = 0, Y = 0, Z = 220$] relative to the Reference Loop.
2. Determine a suitable power level, P_{M2} , for a flux of $\phi_{d4} -6$ dB. The power for ϕ_{d4} (P_L), and the power for $\phi_{d4} -6$ dB (P_{M2}), are determined by:

$$P_L = \frac{(2 \cdot \pi \cdot f \cdot \phi_{d4})^2}{50 \cdot \left(\frac{|50 + Z_{loop}|}{50} \right)^2 \cdot B^2}$$

$$P_{M2} = 10 \cdot \log(P_L \cdot 1000) - \text{Attenuation} - 6\text{dB} \text{ [dBm]}$$

where: $f = 27.095$ MHz
 $Z_{loop} = R_{loop} + j X_{loop} \Omega$ (actual impedance in the absence of any antenna)
 $P_L =$ Power measured out of the Reference Loop [W]
 $B =$ Reference Loop matching transfer ratio
 $P_{M2} =$ The power for $\phi_{d4} -6$ dB
Attenuation = Attenuation of Balun (item 20) + Attenuator (item 31) together with the cable from the Reference Loop to the power meter sensor head [dB]¹¹

The flux level absolute accuracy should be ± 1 dB. The relative accuracy when this flux level shall be re-created needs to be ± 0.2 dB.

Measure the Attenuation and calculate the value of P_{M2} .

3. Set the Signal Generator to the frequency 27.095 MHz, and to CW.
4. Adjust the input power to the Activation Antenna in order to achieve $\phi_{d4} - 6$ dB through the Reference Loop.
Record the reading of Power Meter 1 and call it P_{27AA} .

¹¹ As an example, assuming that Z_{loop} is small compared to 50Ω , $\phi_{d4}=200$ nVs, $B=1$, and that the Attenuation equals 20 dB, then the power level P_{M2} will be 17.6 dBm for the Standard Size Reference Loop. For the Reduced Size Reference Loop, the corresponding value for ϕ_{d4} is 130 nVs, which gives $P_{M2}=13.9$ dBm.

4.2.5.3 Calibration of Balise response

4.2.5.3.1 Calibration Configuration

Proposed calibration set-ups are shown in Figure 18 and Figure 19 below. Clause F1 of Annex F on page 297 gives an example of suitable test equipment. See also sub-clause 4.2.1 on page 23.

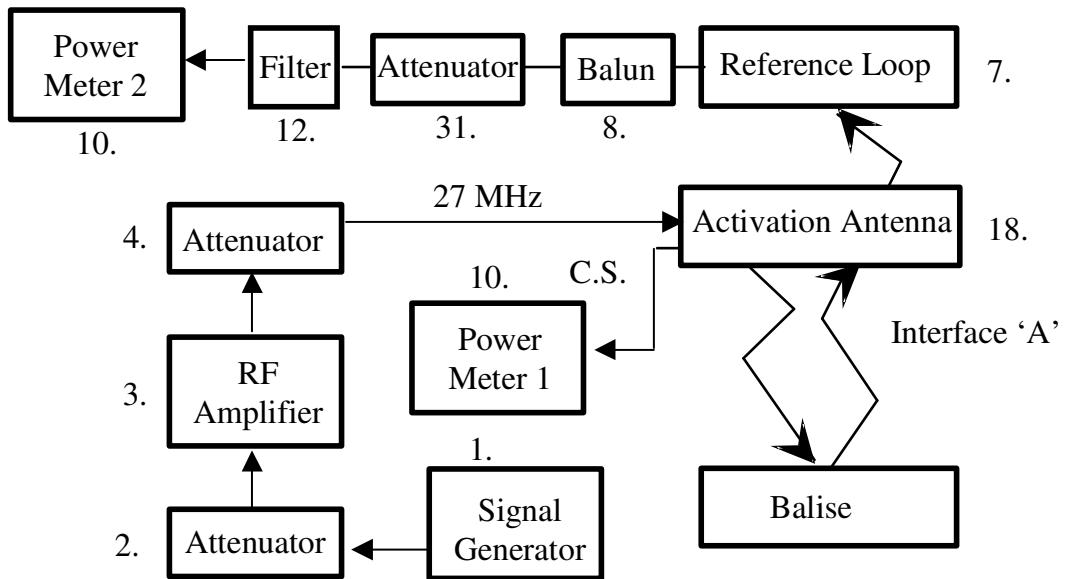

Figure 18: Test set-up 1 for calibration of 4.2 MHz Up-link current

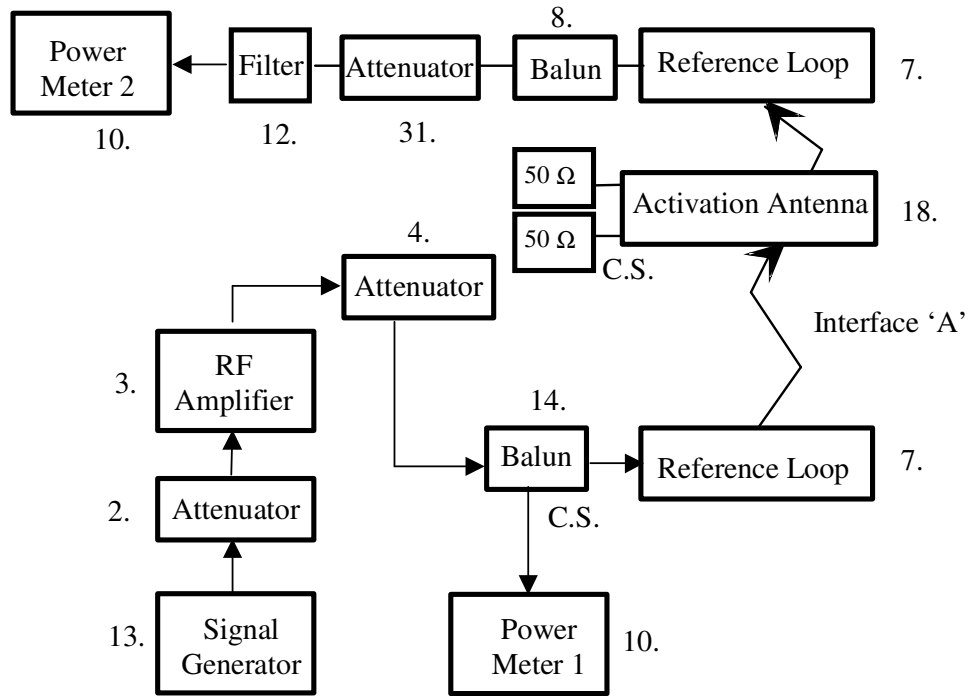

Figure 19: Test set-up 2 for calibration of 4.2 MHz Up-link current

4.2.5.3.2 Calibration Abstract

This calibration procedure will give a value of the Up-link current in the Balise. The current is measured at a flux level of $\phi_{d4} -6$ dB through the Reference Area. The procedure to measure the current is divided in two parts.

First, the Balise is Tele-powered with a flux of $\phi_{d4} -6$ dB and the Up-link signal from the Balise is measured with a Reference Loop. The test set-up in Figure 18 is used for this first part.

Then, the Balise is replaced with a second Reference Loop that acts as a transmitter of the Up-Link signal. The current in the transmitting Loop is increased until the receiving Loop measures the same Up-link signal level as from the Balise. The current in the transmitting Loop is measured with a Current Sense Balun. The test set-up in Figure 19 is used for this second part.

4.2.5.3.3 Calibration Procedure

1. Position the Activation Antenna in position $[x = 0, y = 0, z = 220]$ relative to the Balise, see Figure 18 on page 56 for calibration set-up.
2. Position the Reference Loop in position $[x = 0, y = 0, z = 460]$ relative to the Balise.
3. Set the Signal Generator to the frequency 27.095 MHz, and to CW.
4. Adjust the input power to the Activation Antenna in order to achieve approximately $\phi_{d4} -6$ dB through the Balise. This is performed by increasing the power from the signal generator until Power Meter 1 reads P_{27AA} , which is the calibration value for $\phi_{d4} -6$ dB measured in sub-clause 4.2.5.2.3 on page 55.
5. Record the reading of Power Meter 2 and call it P_{42REF} .
6. Change the calibration set-up by replacing the Balise with a Reference Loop that shall transmit the 4.2 MHz signal. See Figure 19 on page 57 for calibration set-up.
7. Set the Signal Generator to transmit the 4.2 MHz FSK signal carrying telegram type 1.
8. Adjust the input power to the transmitting Reference Loop in order to achieve the same current in the Reference Loop as in the Balise. This is performed by increasing the power from the signal generator until Power Meter 2 reads P_{42REF} .
9. Power Meter 1 now shows a value that corresponds to the current in the Reference Loop. This current is equal to the 4.2 MHz current that flows in this particular Balise at a Tele-Powering flux of $\phi_{d4} -6$ dB. To calibrate the Current Sense balun and to calculate the actual current from Power Meter 1 reading, see clause H5 of Annex H on page 327. Calculate the current and call it I_{BAL} .

4.2.5.4.2 Test Procedure, Up-link Cross-talk from Balise to cable

One case of cross-talk with cable for the Up-Link is when a Balise in one track is activated by a vehicle, and at the same time another vehicle is present over a cable crossing both tracks. See figure below.

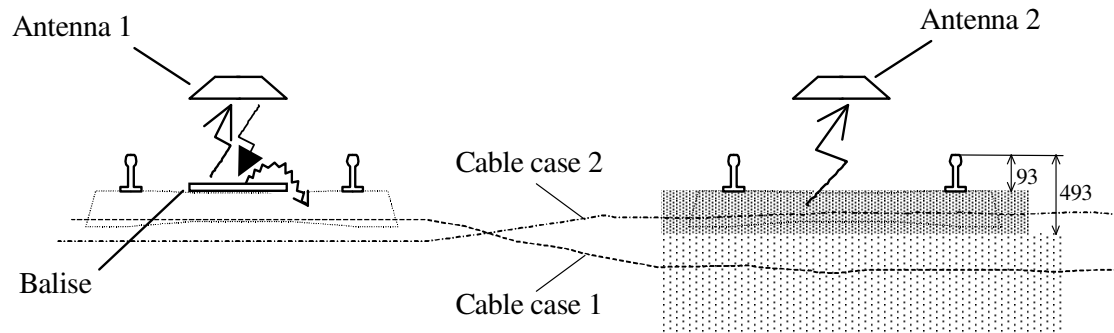

Two different cases are specified in UNISIG SUBSET-036. The first case, in this document called case 1, is a cable crossing the track without Balise in the area from 493 mm below top of rail and further down. The second case, in this document called case 2, is a cable crossing the track without Balise in the area from 93 mm to 493 mm below the top of rail. The maximum 4.2 MHz current defined in UNISIG SUBSET-036 is:

- in case 1 10 mA
- in case 2 2 mA

The distances A, B, and C shown in Figure 20 on page 59 are defined by the supplier of the Balise, and it shall be stated by the supplier for which installation case (1 or 2) the distances are valid. This gives the allowed current induced in a cable. The distances A, B, and C refer to directions in the track. A is in the x-direction, B is in the y-direction, and C is in the z-direction.

The test set-up shown in Figure 20 on page 59 shall be used. The resistors R1 and R2 shall be 400 Ω . In case no A, B, and C are given by the supplier, use A, B, and C = 1000 mm, and installation case 2, which allows a maximum current of 2 mA in a cable. This test measure the current induced from the Balise in a cable with the characteristic impedance 400 Ω . The Balise under test may be a “strong” or a “weak” Balise. Therefore, the measured result shall be compensated to reflect a Balise with the strongest allowed signal. Cables out in reality may have other impedance than in this test set-up. Therefore, the measured current shall be compensated to reflect the current in a “worst case” cable. This compensation needs to take into account standing waves and other phenomena.

For a Reduced size Balise that may be mounted both longitudinal and transversal, the supplier of the Balise shall give two sets of A, B, and C, one for each mounting. The measurement procedure shall in this case be performed with both sets of A, B, and C values.

Cable parallel with track:

1. Position the Activation Antenna in position $[x = 0, y = 0, z = 220]$ relative to the Balise. This position shall be fixed relative to the Balise during the test. Throughout this test “position the Balise” means “position the Balise and the Activation Antenna”. Please note that the same Activation Antenna and the same Balise shall be used also in the calibration in sub-clause 4.2.5.2.3 on page 55.
2. Position the Balise at the distance B and C = supplier minimum distance in y and z direction from the iron bars simulating the cable.
3. Set the Signal Generator to the frequency 27.095 MHz, and to CW.
4. Adjust the input power to the Activation Antenna in order to achieve approximately $\phi_{d4} - 6$ dB through the Balise. This is performed by increasing the power from the signal generator until Power Meter 1 reads P_{27AA} , which is the calibration value for $\phi_{d4} - 6$ dB measured in sub-clause 4.2.5.2.3 on page 55.

5. Record the reading of the Spectrum Analyser and call it P_{42IBC} .
6. Position the Balise at regular intervals of +20 mm further away from the iron bars, up to the distance $B =$ supplier minimum distance +500 mm. For each position, record the reading of the Spectrum Analyser, and call it P_{42IBC} .

Cable crossing track:

1. Position the Activation Antenna in position [$x = 0, y = 0, z = 220$] relative to the Balise. This position shall be fixed relative to the Balise during the test. Throughout this test “position the Balise” means “position the Balise and the Activation Antenna”.
2. Position the Balise at the distances A and $C =$ supplier minimum distances in the x and z directions from the iron bars.
3. Set the Signal Generator to the frequency 27.095 MHz, and to CW.
4. Adjust the input power to the Activation Antenna in order to achieve approximately $\phi_{d4} - 6$ dB through the Balise. This is performed by increasing the power from the signal generator until Power Meter 1 reads P_{27AA} , which is the calibration value for $\phi_{d4} - 6$ dB measured in sub-clause 4.2.5.2.3 on page 55.
5. Record the reading of the Spectrum Analyser, and call it P_{42IBC} .
6. Position the Balise at regular intervals of +20 mm further away from the iron bars, up to the distance $A =$ supplier minimum distance +500 mm. For each position, record the reading of the Spectrum Analyser and call it P_{42IBC} .

The results from the test are a set of P_{42IBC} values. Calculate the current that corresponds to the maximum value and call it I_{42BC} . For the suggested current probe, the current of 1 mA will give a voltage of 1 mV into 50 Ω . Therefore, the current is calculated with the following equation:

$$I_{42BC} = \sqrt{P_{42IBC} \times 50} \quad \text{Where } P \text{ is measured in [W], and } I \text{ is measured in [A]}$$

Compensate the current for the difference between the actual Balise current and the company specific maximum Balise current possible ($I_{u\max}$) for the Balise type under test ($I_{u\max} \leq I_{u3}$). The actual Balise current I_{BAL} is measured in sub-clause 4.2.5.3.3 on page 58. Call the compensated value $I_{42BCCOMP}$.

$$I_{42BCCOMP} = \frac{I_{42BC} \times I_{u\max}}{I_{BAL}}$$

To reflect the current induced in real cables, the value $I_{42BCCOMP}$ shall be compensated for the difference between the test set-up impedance and the “worst case” real impedance using the following equation.

$$I_{42BCWORST} = \frac{I_{42BCCOMP} \times Z_{\text{setup}}}{Z_{\text{worst_case}}} \quad \text{Where } Z_{\text{setup}} = 800 \Omega$$

The value $I_{42BCWORST}$ shall be lower than the current allowed for the specified installation case 1 or 2, which allows 10 mA or 2 mA respectively.

Note that $Z_{\text{worst_case}}$ is a fictitious impedance that includes the cable impedance and effects of standing waves, metallic objects etceteras, and that it is used to transform the current induced in the test set-up to real conditions. The value of $Z_{\text{worst_case}}$ consequently depends on cable installation rules (and thus is manufacturer dependent), and shall be stated by the Balise manufacturer.

4.2.5.5 LZB Cable Testing

4.2.5.5.1 General

The following considerations apply:

- The test object is the Balise combined with appropriate fixation devices for the cable, and company specific installation rules.
- The test tools of Annex J need adaptations to cope with the actual test object for properly fitting the test object to the tools.
- Testing related to the Balise is optional (applicable only when the Balise is intended to be used in the presence of LZB cables).

In general the optional testing applies to:

- Measurement of 4.2 MHz Up-link induction from the Balise into a simulated LZB loop with an impedance of 75 Ω .
- Balise behaviour when subjected to 27 MHz induction from an On-board equipment into a simulated LZB loop with an impedance of 75 Ω .

Requirements are defined in UNISIG SUBSET-036.

The tools described in Annex J should be the basis for further adaptations that are needed for properly fitting the test object to the tools. Please observe that the 75 Ω set-up impedance must always remain for the purpose of testing of Up-link induction.

4.2.5.5.2 Test set-up, Up-link Induction from the Balise

The test set-up according to Figure 21 below applies. Clause F1 of Annex F on page 297 gives an example of suitable test equipment. Additional details related to the vertically positioned LZB loop is found in sub-clause J2.2 on page 333. See also sub-clause 4.2.1 on page 23.

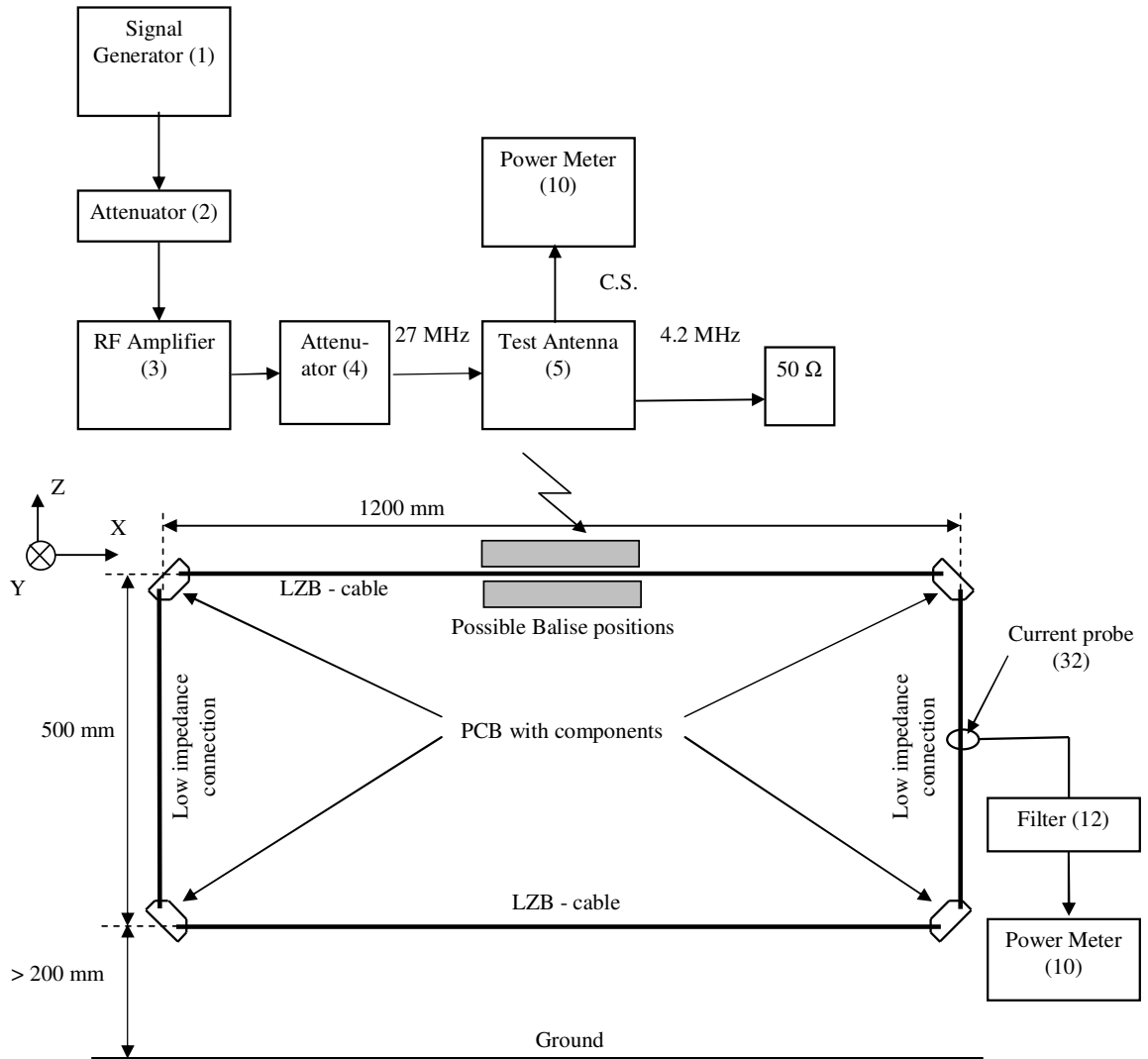

Figure 21: Test set-up, Up-link induction from the Balise

4.2.5.5.3 Test procedure, Up-link Induction from the Balise

The following procedure applies:

1. Position the Test Antenna such that it is in position [X=0, Y=0, Z=460] with respect to the position where the reference marks of the Balise is to be placed.
2. Calibrate the flux such that $\phi_{d4} - 10$ dB is obtained through the Balise. The proper calibration procedure is found in sub-clause 4.2.3.2.3 on page 41.
3. Insert the Balise, and appropriate fixation devices for the cable according to company specific installation rules. The reference position of the tool (X = 0) is at the midpoint of the longer upper horizontal cable segment of the tool.
4. Measure and record the current through the LZB loop when the LZB loop segment is positioned according to the nominal company specific installation rules.
5. Verify that the limit defined in UNISIG SUBSET-036 is not exceeded.
6. Repeat steps 4 and 5 at the worst case installation conditions derived from the associated manufacturer dependent installation tolerances.

4.2.5.5.4 Test set-up, Tele-powering Induction from the On-board Equipment

The test set-up according to Figure 22 below applies. Clause F1 of Annex F on page 297 gives an example of suitable test equipment. Additional details related to the vertically positioned LZB loop is found in sub-clause J2.4 on page 338. See also sub-clause 4.2.1 on page 23.

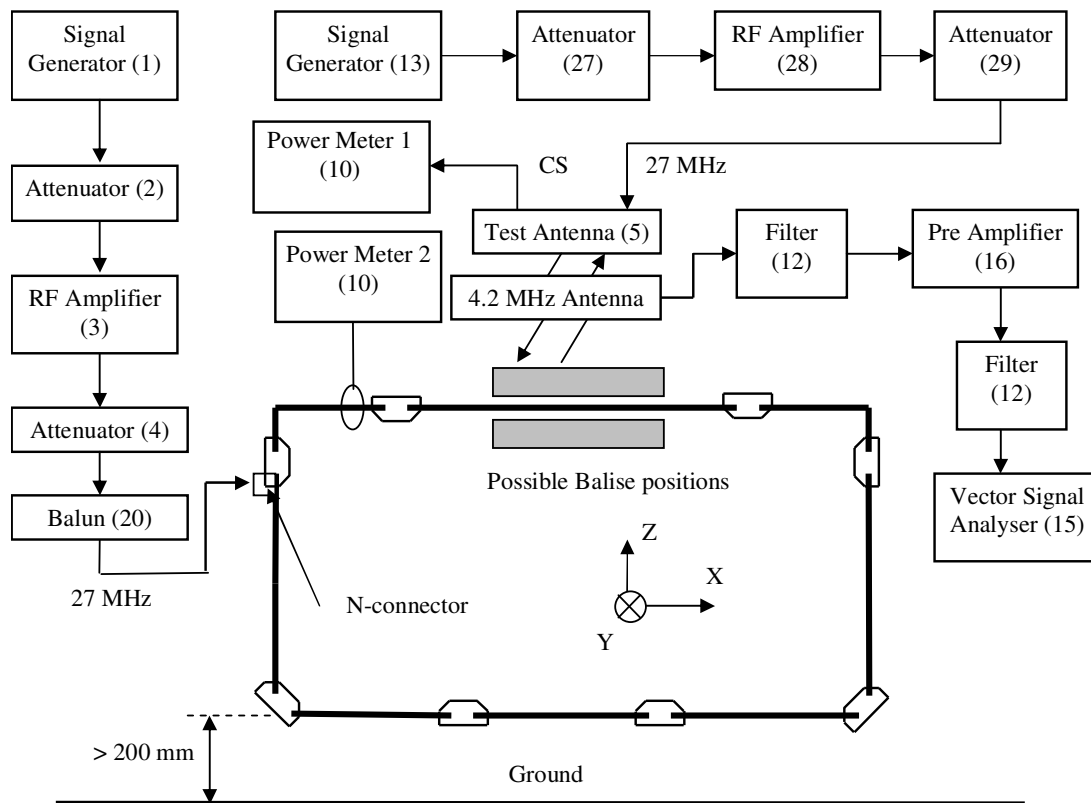

Figure 22: Test set-up, Tele-powering injection from the LZB Cable

4.2.5.5.5 Test procedure, Tele-powering Induction from the On-board Equipment

The following procedure applies:

1. Position the Test Antenna such that it is in position $[X = 0, Y = 0, Z = 460]$ with respect to the position where the reference marks of the Balise are to be placed, and the 4.2 MHz Antenna such that it is in position $[X = 0, Y = 0, Z = 100]$ with respect to the position where the reference marks of the Balise are to be placed.
2. Calibrate the 4.2 MHz Antenna with respect to the response from the Up-link signal using a Reference loop temporarily positioned at the intended position of the Balise. This is performed through driving the current I_{u1} -10 dB through the Reference Loop and recording the reading of the vector signal analyser.
3. Remove the Reference Loop and insert the Balise, appropriate fixation devices for the cable, but without possible RF chokes or similar devices, according to company specific installation rules. The reference position of the tool ($X = 0$) is at the midpoint of the longer upper horizontal cable segment of the tool.
4. Calibrate the 27.095 MHz CW current through the LZB loop (using Power Meter 2) such that the current defined in UNISIG SUBSET-036 is obtained through the tool.
5. Measure and record the Up link signal possibly generated by the Balise (using the 4.2 MHz Antenna and the vector signal analyser).
6. Verify that the Balise is not activated (see the related definition of UNISIG SUBSET-036).

Please observe that the balun shall be the same unit as the one used during tuning of the LZB loop.

7. Temporarily insert a Reference Loop at the position where the Balise is supposed to be positioned.
8. Perform a calibration of 27.090 MHz CW flux generated by item 13 in accordance with sub-clause 4.2.7.5 on page 79. Please observe that there shall be no (intentional) current through the LZB tool.
9. Insert the Balise instead of the Reference Loop.
10. Apply the defined calibrated 27.100 MHz CW current through the LZB loop (using Power Meter 2) such that the current defined in UNISIG SUBSET-036 is obtained through the tool.
11. For the condition CW Tele-powering, nominal start-up ramp, and flux level 2 (all according to sub-clause 4.2.7.2.3 on page 73), perform the following tests:
 - Test of Centre Frequency (sub-clause 4.2.7.6 on page 81)
 - Test of Frequency Deviation (sub-clause 4.2.7.6 on page 81)
12. Repeat step 11 using toggling Tele-powering transmitted by the Test Antenna.

Please observe that item 1 shall be set to generate the frequency 27.100 MHz and item 13 shall be set to generate the frequency 27.090 MHz in steps 7 through 13.

4.2.6 Balise Impedance

4.2.6.1 General

4.2.6.1.1 Introduction

This sub-clause defines the test procedure for Balise Impedance Tests and the related calibrations that are required. A set of recommended test equipment is also included.

The Test Procedure includes a number of different steps with partially different test set-ups. The main steps are:

- Calibration of 27 MHz Tele-powering flux ϕ .
- Calibration of Network Analyser set-up.
- Balise Impedance measurements.

The calibration of 27 MHz Tele-powering is performed in order to define a specific magnetic flux through the Balise active Reference Area.

Verification of 4.2 MHz Balise Up-link current can be omitted, because it can be assumed that the input-to-output characteristics of the Balise to be submitted to the Impedance Test are compliant with the requirements of UNISIG SUBSET-036.

The calibration of 27 MHz Tele-powering defines the measurement point for the Impedance Test of the Balise to be within the flux interval $\phi_{d4} +0/-3$ dB as shown in Figure 23 below.

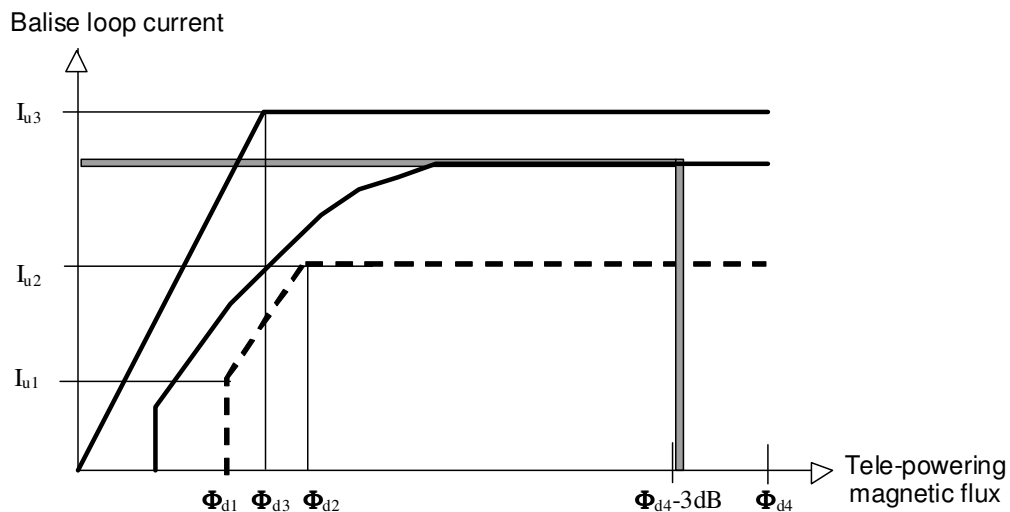

Figure 23: Balise Impedance Calibration Point

4.2.6.1.2 Impedance Requirements

When the Balise receives a flux ϕ_d from the Antenna Unit, a voltage is induced in the Balise receiver loop. The Balise loads the induced voltage, which in turn generates a current $I_{\text{reflected}}$ in the receiver loop. This current may influence the Antenna Unit. This interaction can be expressed as the impedance $Z_{\text{reflected}}$ (the induced voltage $\omega\phi_d$ divided by the current $I_{\text{reflected}}$).

UNISIG SUBSET-036 states that the absolute value of the complex impedance $Z_{\text{reflected}}$ of the Standard Size Balise shall be higher than 60Ω when the Balise receives a flux reaching $\phi_{d4} +0/-3$ dB.

UNISIG SUBSET-036 states that the absolute value of the complex impedance $Z_{\text{reflected}}$ of the Reduced Size Balise shall be higher than 40Ω when the Balise receives a flux reaching $\phi_{d4} +0/-3$ dB.

4.2.6.2 Test Conditions

The test should be performed in a laboratory environment where no other H-field exists except the one that is to be present for test purposes. The Reference Loops and Balises shall be separated more than 1 m from any metallic object during the measurements.

Calibrations and measurements shall be performed for the following position of the Test Antenna, relative to the Reference Loop:

$$[X = 0, Y = 0, Z = 220]$$

The positioning system should have accuracy in displacement in the X, Y, and Z directions of better than 2 mm. It is also essential that the positioning system does not disturb the field distribution.

4.2.6.3 Calibration of 27 MHz Tele-powering flux

4.2.6.3.1 Calibration Configuration

See sub-clause 4.2.3.2.1 on page 39.

After calibration of the 27 MHz Tele-powering flux, the Balise Impedance Measurements are performed using the test configuration shown in Figure 24 on page 69. For this configuration the Signal Generator (item 1) in Figure 10 on page 39 for 27 MHz is substituted by the network analyser (item 22).

4.2.6.3.2 Calibration Procedure

1. Position the Test Antenna in position [X = 0, Y = 0, Z = 220] relative to the Reference Loop.
2. Determine the power level for where it is relevant to perform the calibration using the following equation:

$$\phi = \frac{B \cdot \sqrt{50 \cdot P_L}}{2 \cdot \pi \cdot f} \cdot \left(\frac{|50 + Z_{loop}|}{50} \right)$$

where: f = 27.095 MHz

$Z_{loop} = R_{loop} + j X_{loop} \Omega$ (actual impedance in the absence of any antenna)

$P_L = P_{M3} + \text{Attenuation}$

B = Reference Loop matching transfer ratio

P_{M3} = Power measured by Power Meter 3 ¹²

Attenuation = Attenuation of Balun (item 20) + Attenuator (item 9)

3. Set the Signal Generator to the frequency 27.095 MHz, and to CW.
4. Adjust the power level such that the requested flux level is obtained. As an example, the input power to the Test Antenna should be approximately +21 dBm measured by Power Meter 3 (or +17.5 dBm for the Reduced Size type). For this power measurement, the attenuator, item 9, should be capable of handling a power dissipation of 20 W.
5. Record the exact reading of Power Meter 3.
6. Record the reading of Power Meter 2. This power value shall be maintained to the same level during the impedance measurements according to sub-clause 4.2.6.4 on page 69 (when the network analyser substitutes the signal generator for 27 MHz).

¹² As an example, assuming that Z_{loop} is small compared to 50 Ω and that B equals one, then a power level P_{M3} of +21 dBm should be selected for the Standard Size Reference Loop. This corresponds to a flux of approximately 150 nVs. This is a relevant calibration point for the Standard Size Reference Loop. For the Reduced Size Reference Loop, the corresponding values are +17,5 dBm and 100 nVs respectively. If the assumptions are not fulfilled, then the power levels have to be modified.

4.2.6.4 Balise Impedance Measurements

4.2.6.4.1 Test Configuration

A proposed test set-up is shown in Figure 24 below. Clause F1 of Annex F on page 297 gives an example of suitable test equipment. “Reference Load” refers to “open”, “short”, and “50 Ω reference” normally used during a full one port calibration of the network analyser. Item 7 is substituted by a Balise during the Balise Impedance Measurement described in sub-clause 4.2.6.4.3 on page 70. Please note that no balun shall be used when connecting the Reference Load to the Reference Loop. See also sub-clause 4.2.1 on page 23.

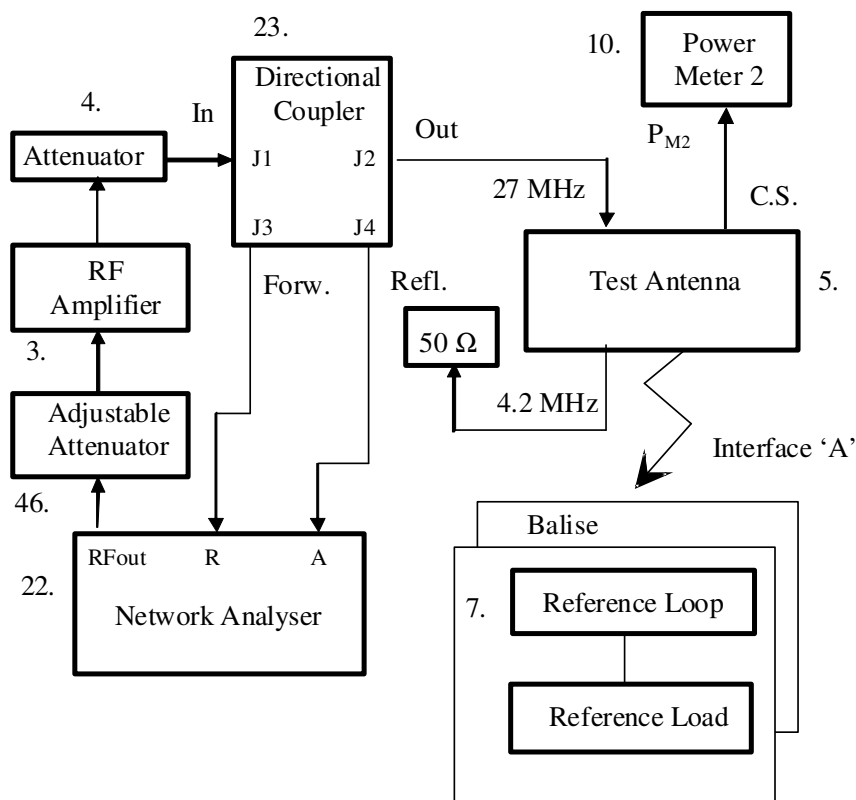

Figure 24: Test set-up for Balise Impedance Measurements

4.2.6.4.2 Calibration Procedure

The network analyser (item 22) is used to measure the input impedance of the Test Antenna. The following set-up should be used:

Network analyser set-up:

Measurement Type:	S11 (A/R)
Format:	Smith Chart
Sweep Type:	Power Sweep
Centre:	X dBm (X related to the flux)
Span:	0 dBm
Cont. Wave:	27.095 MHz

A “full one port calibration” shall be performed by connecting “open”, “short”, and “50 Ω reference” to the output port of the Reference Loop. Please note that high power will occur in this point, and that the calibration load might be damaged.¹³

1. Position the Test Antenna in position [X = 0, Y = 0, Z = 220] relative to the Reference Loop.
2. Connect the Reference Loop according to the set-up in Figure 24 on page 69.
3. Switch on the input power to the Test Antenna. Adjust the power in order to achieve the same power level recorded with Power Meter 2 as during the calibration of 27 MHz Tele-powering flux (see sub-clause 4.2.6.3 on page 68) using the adjustable attenuator.
4. Perform a “full one port calibration” as described above (with Reference Loads connected to the output of the Reference Loop).
5. Switch off the power.
6. Disconnect the Reference Loop.

4.2.6.4.3 Tests Procedure

For the Balise Impedance Measurements, the same test set-up as shown in Figure 24 on page 69 shall be maintained. The only difference is that the Balise now replaces the Reference Loop (and the Reference Load).

1. Maintain the network analyser set-up and calibration as used in sub-clause 4.2.6.4.2.
2. Position the Test Antenna in position [X = 0, Y = 0, Z = 220] relative to Balise.
3. Adjust the input power to the Test Antenna in order to achieve the same power level recorded by Power Meter 2 as during the calibration of 27 MHz Tele-powering flux (see sub-clause 4.2.6.3 on page 68).
4. Measure the input impedance of the Test Antenna (Z_{in}) with the network analyser and record the value.
5. Calculate the final value for the Balise impedance using the following:

$$Z_{balise} = Z_{in} + Z_{loop}$$

where Z_{loop} is the free air impedance of the Reference Loop (marked on the device).

¹³ A suitable solution is to use a power attenuator with low VSWR (< 1.05) in front of the 50 Ω calibration load during the network analyser calibration. The use of a potential attenuator only applies to the case when calibrating with the 50 Ω reference load.

4.2.7 Up-link Signal Characteristics

4.2.7.1 General

4.2.7.1.1 Introduction

This sub-clause defines measurement methods for verifying Up-link FSK performance of Balises, as defined by UNISIG SUBSET-036. It also includes recommended test set-ups.

The measurement conditions according to 4.2.7.2.3 on page 73 include several different levels of 27 MHz Tele-powering flux. To achieve these levels, a calibration in accordance with sub-clause 4.2.7.5 on page 79 is required before testing.

The general test set-up for all tests is found in sub-clause 4.2.7.1.2 below, and the specific set-up recommended for calibration is found in sub-clause 4.2.7.5.1 on page 79.

4.2.7.1.2 Test set-up for Up-link FSK measurements

A proposed test set-up is shown in Figure 25 below. Clause F1 of Annex F on page 297 gives an example of suitable test equipment. The Reference Signal Generator is only applicable for controlled Balises. See also sub-clause 4.2.1 on page 23.

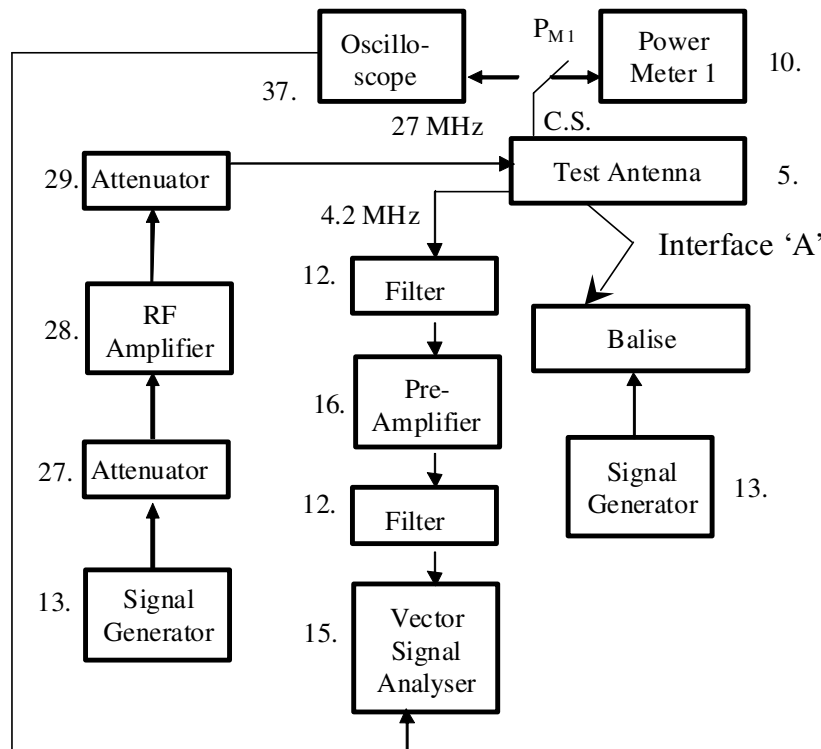

Figure 25: Test set-up for Up-link FSK measurements

If the received 4.2 MHz signal is judged being too low for accurately performing the measurements, it is preferred to complement the test set-up with a 4.2 MHz Antenna at sufficiently low height used for reception of the Up-link signal. In such a case, the calibration principle should be in accordance with sub-clause 4.2.3.2 on page 39.

4.2.7.2 Nominal Test Conditions

4.2.7.2.1 Metallic objects and Debris

No metallic objects shall be present.

No debris shall be applied.

4.2.7.2.2 Test Distance

The vertical distance between the Test Antenna and the Balise shall be 460 mm \pm 2 mm from the centre of the Test Antenna loop to the Reference marks of the Balise.

4.2.7.2.3 Tele-powering flux characteristics

The Tele-powering flux shall have the following characteristics:

The frequency shall be 27.095 MHz \pm 200 ppm.

Three different modulations shall apply:

- CW
- Toggling AM
- Non-toggling AM

CW is defined as no modulation (constant amplitude).

Unless otherwise stated, measurements shall be performed for “CW” and for “Toggling AM” 27 MHz Tele-powering signal.

“Toggling AM” is defined according to UNISIG SUBSET-036. The modulation depth shall be at 52 % \pm 2 %, and the pulse width variation shall be 0.81 μ s \pm 0.01 μ s during these tests. The current specification (UNISIG SUBSET-036) allows for various rise and fall times.

“Non-toggling AM” is defined according to UNISIG SUBSET-036. The modulation depth shall be 52 % \pm 2 %, and within the range 85 % to 100 % during these tests. These conditions are intended to be “worst case” of those defined in UNISIG SUBSET-036.

In addition to the above defined modulation characteristics, the flux shall also be modulated to simulate a train passage according to the following:

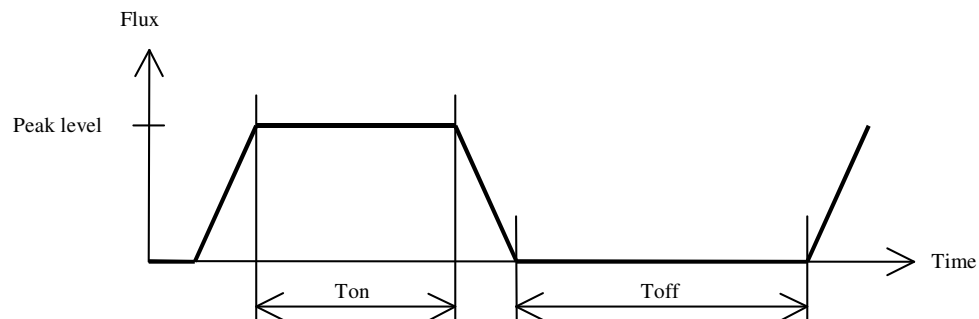

Figure 26: Simulated train passage

The start-up and end ramps shall have a slope of 10 nVs/ms for a standard size Balise, and 5 nVs/ms for a reduced size Balise.

Please consider that the slopes are typical test cases only, not implying any On-board limitations.

Unless otherwise explicitly stated, “CW” measurements shall start 150 μ s after the 27 MHz Tele-powering flux has reached the level ϕ_{d1} on the start up ramp, or when the flux has reached the defined peak level, whichever comes last.

Unless otherwise explicitly stated, “Toggling AM” measurements shall start 250 μ s after the 27 MHz Tele-powering flux has reached the level ϕ_{d1} on the start up ramp, or when the flux has reached the defined peak level, whichever comes last.

Calibrate triggering level with the actual test object, using the current sense output from the Test Antenna.

Dynamic properties of the signal shall be measured at the current sense output of the test antenna.

The duration, T_{on} , shall be sufficient for the measurements performed.

The off-time between successive activation periods, T_{off} , shall be sufficient to give a duty cycle of less than 1 %. The duty cycle shall be calculated based on the 50 % points on the flux level curve.

The Tele-powering flux shall be defined at three different levels:

Level	Value
1	$\phi_{d1} + 0.8 \text{ dB} \pm 0.5 \text{ dB}$
2	$\phi_{d2} \pm 1 \text{ dB}$
3	$\phi_{d2} + 10 \text{ dB} \pm 1 \text{ dB}$

Table 1: Tele-powering Flux Levels

4.2.7.2.4 Telegram Contents

The Balise shall transmit a randomised 341 bit telegram that is valid (fulfilling the coding requirements according to UNISIG SUBSET-036), and which consists of 50 % \pm 2 % of logical “one”. The telegram shall comprise an even distributed run length, based upon a truncated close to exponential distribution of transitions. This is Telegram Type 1 according to clause A2 of Annex A on page 161.

4.2.7.2.5 Balise controlling interface characteristics

If the Balise is controlled by a Reference Signal Generator, the signals in the Balise controlling interface shall either have their nominal parameter values (“enabled Reference Signal Generator”) or be according to “disabled Reference Signal Generator” conditions. “Disabled Reference Signal Generator” means that no signals are present at the Balise controlling interface.

Unless otherwise stated, for controlled Balises, measurements shall be performed both with the Reference Signal Generator enabled, and with it disabled.

4.2.7.3 Specific Test Conditions

4.2.7.3.1 Metallic objects

- The “Metallic plane underneath the Balise” condition is defined in sub-clause B5.3.3 of Annex B on page 199. The Test Antenna shall be subjected to free air conditions.
- The “Steel sleeper underneath the Balise” condition is defined in sub-clause B5.3.4 of Annex B on page 200. The Test Antenna shall be subjected to free air conditions.

4.2.7.3.2 Debris

The design of the Debris Box, and the utilisation, is according to sub-clause B5.2.1 of Annex B on page 191

- The “Salt water” condition is defined in sub-clause B5.2.4.1 of Annex B on page 193. The Test Antenna shall be subjected to free air conditions. The manufacturer of the Balise shall define which debris class (A or B) that is applicable.
- The “Clear water” condition is defined in sub-clause B5.2.4.2 of Annex B on page 193. The Test Antenna shall be subjected to free air conditions. The manufacturer of the Balise shall define which debris class (A or B) that is applicable.
- The “Iron ore (Magnetite)” condition is defined in sub-clause B5.2.4.3 of Annex B on page 193. The Test Antenna shall be subjected to free air conditions. The manufacturer of the Balise shall define which debris class (A or B) that is applicable.

4.2.7.3.3 Test Distance

See sub-clause 4.2.7.2.2 on page 73.

4.2.7.3.4 Tele-powering flux characteristics

See sub-clause 4.2.7.2.3 on page 73.

4.2.7.3.5 Telegram Contents

The telegrams to be tested shall be of the short (341 bits) and long (1023 bits) length, and be valid (fulfilling the coding requirements according to UNISIG SUBSET-036). Eighteen different characteristics shall be defined according to clause A2 of Annex A on page 161.

4.2.7.3.6 Balise controlling interface characteristics

Extreme Balise controlling interface conditions are defined by sub-clause 4.2.8.3 on page 91.

For controlled Balises, two conditions are applicable, both with a physical connection between the Balise and the Reference Signal Generator. The first is with the Reference Signal Generator enabled (producing valid Balise controlling interface signals). The second is with the Reference Signal Generator disabled (producing no signals at the Balise controlling interface).

Unless otherwise stated, for controlled Balises, measurements shall be performed both with the Reference Signal Generator enabled, and with it disabled.

4.2.7.4 Toggling AM Test Conditions

4.2.7.4.1 Metallic objects and Debris

See sub-clause 4.2.7.2.1 on page 73.

4.2.7.4.2 Test Distance

See sub-clause 4.2.7.2.2 on page 73.

4.2.7.4.3 Tele-powering flux characteristics

“Toggling AM” is defined according to UNISIG SUBSET-036. The following characteristics apply:

The carrier frequency shall be 27.095 MHz \pm 200 ppm.

Rise and fall times of the modulation pulses shall be in accordance with Figure 27 and Table 2 below.

Modulation pulse width shall be 2.1 μ s \pm 0.1 μ s.

Toggling shall be 0.81 μ s \pm 0.01 μ s (i.e., one pulse is nominally 2.1 μ s and the other is 2.9 μ s).

Modulation depth shall be at 52 % \pm 2 %, and within the range 85 % to 100 %.

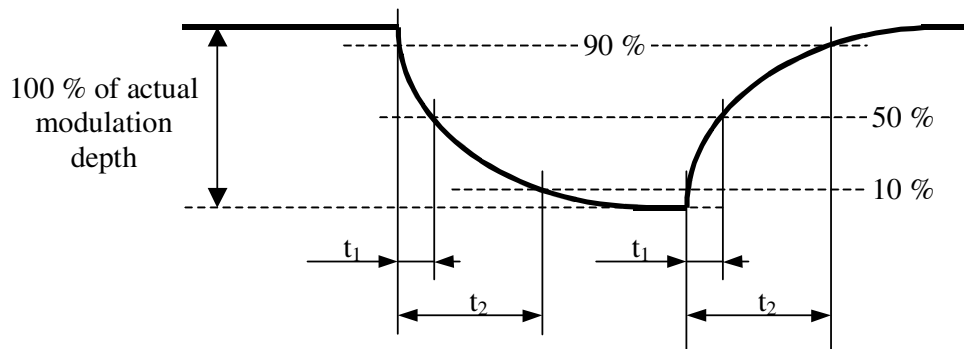

Figure 27: Definition of Modulation Pulse parameters (for testing)

Parameter	Nominal value	Tolerance
t1 fast	300 ns	\pm 10 %
t2 fast	950 ns	\pm 10 %
t1 slow _{2,1}	450 ns	\pm 10 %
t2 slow _{2,1}	1500 ns	\pm 10 %
t1 slow _{2,9}	500 ns	\pm 10 %
t2 slow _{2,9}	1750 ns	\pm 10 %

Table 2: Modulation Pulse parameter values (for testing)

In addition to the above defined modulation characteristics, the flux shall also be modulated to simulate a train passage according to the following:

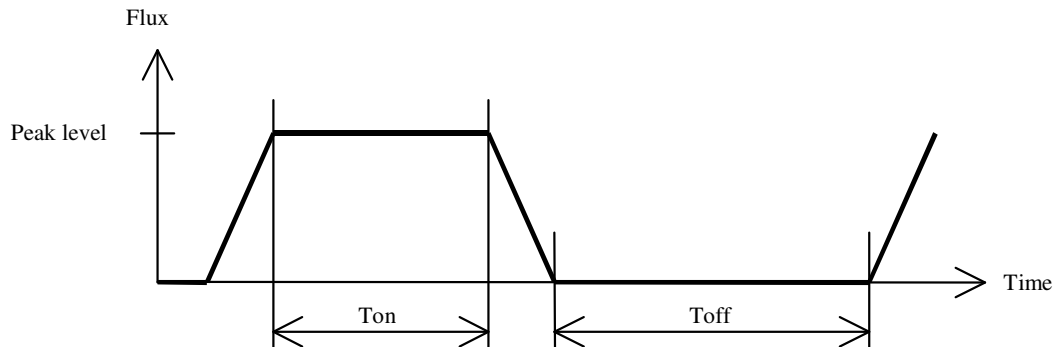

Figure 28: Simulated train passage

The start-up and end ramps shall have a slope of 2 nVs/ms and 80 nVs/ms for a Standard Size Balise. For the Reduced Size Balise, 1 nVs/ms and 40 nVs/ms apply.

Please consider that the slopes are typical test cases only, not implying any On-board limitations.

Measurements shall start 250 μ s after the 27 MHz Tele-powering flux has reached the level ϕ_{d1} on the start up ramp.

Calibrate triggering level with the actual test object, using the current sense output from the Test Antenna.

Dynamic properties of the signal shall be measured at the current sense output of the test antenna.

The duration, T_{on} , shall be sufficient for the measurements performed.

The off-time between successive activation periods, T_{off} , shall be sufficient to give a duty cycle of less than 1 %. The duty cycle shall be calculated based on the 50 % points on the flux level curve.

The Tele-powering flux peak level shall be defined at $\phi_{d2} + 10 \text{ dB} \pm 1 \text{ dB}$.

4.2.7.4.4 Telegram Contents

See sub-clause 4.2.7.2.4 on page 75.

4.2.7.4.5 Balise controlling interface characteristics

See sub-clause 4.2.7.2.5 on page 75.

4.2.7.5 Calibration of 27 MHz Tele-powering flux

4.2.7.5.1 Calibration Configuration

A proposed calibration set-up is shown in Figure 29 below. Clause F1 of Annex F on page 297 gives an example of suitable test equipment. See sub-clause 4.2.1 on page 23.

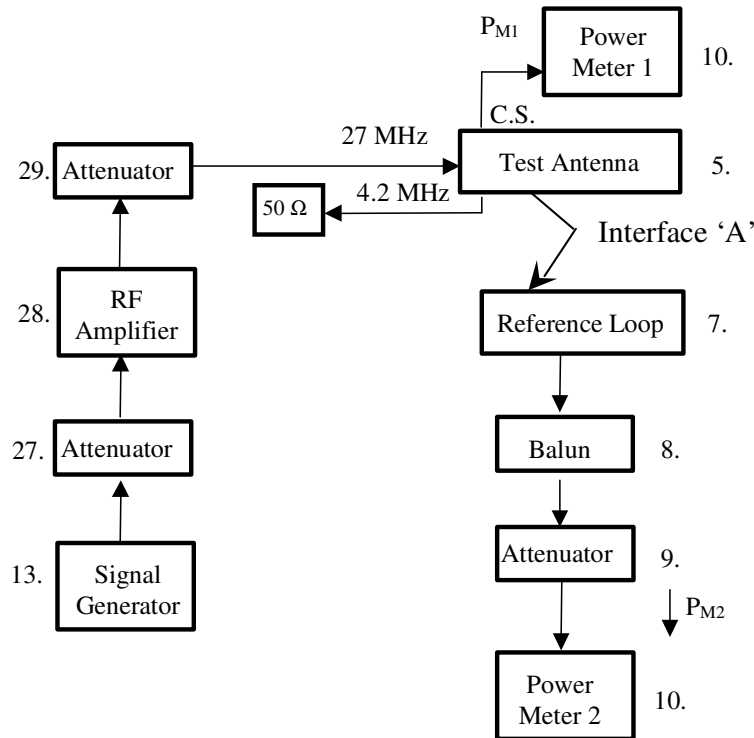

Figure 29: Test set-up for calibration of 27 MHz Tele-powering flux

Please observe the note regarding the test set-up in sub-clause 4.2.7.1.2 on page 72.

4.2.7.5.2 Calibration Abstract

This calibration procedure will give a reference value P_{27AA} . The reference value P_{27AA} is used when activating the Balise with flux levels according to Table 1 on page 75 through the Reference Area.

4.2.7.5.3 Calibration Procedure

1. Position the Test Antenna in position $[x = 0, y = 0, z = 460]$ relative to the Reference Loop.
2. Apply debris according to one of the relevant conditions (including the no debris condition).
3. Determine a suitable power level, P_{M2} , for a flux of ϕ_d (one of the values from Table 1). The power for ϕ_d , P_L , is determined by:

$$P_L = \frac{(2 \cdot \pi \cdot f \cdot \phi_d)^2}{50 \cdot \left(\frac{|50 + Z_{loop}|}{50} \right)^2 \cdot B^2}$$

where: $f = 27.095$ MHz
 $Z_{loop} = R_{loop} + j X_{loop} \Omega$ (actual impedance in the absence of any antenna)
 $P_L =$ Power measured out of the Reference Loop [W]
 $B =$ Reference Loop matching transfer ratio.

$$P_{M2} = 10 \cdot \log(P_L \cdot 1000) - \text{Attenuation [dBm]}$$

where: *Attenuation* equals the attenuation of items 9 and 8 together with the cable from the Reference Loop to the power meter sensor head.¹⁴

Measure the *Attenuation* and calculate the value of P_{M2} .

4. Set the Signal Generator to the frequency 27.095 MHz, and to CW. Ramping the signal according to Figure 26 on page 73 is not applicable to the calibration procedure.
5. Adjust the input power to the Test Antenna in order to achieve approximately ϕ_d through the Reference Loop (through observing the reading of Power Meter 2). Record the reading of Power Meter 1 and call it P_{27AA} . This is the future reference for the specific flux level within the continued testing of signal characteristics.
6. Repeat steps 3 through 5 for all flux levels in Table 1 on page 75.
7. Repeat steps 2 through 6 for all relevant debris conditions.

¹⁴ As an example, assuming that Z_{loop} is small compared to 50Ω , $\phi_d = 200$ nVs, $B = 1$, and that the *Attenuation* equals 20 dB, then the power level P_{M2} will be 23.6 dBm for the Standard Size Reference Loop. For the Reduced Size Reference Loop, the corresponding value for $\phi_d = 130$ nVs gives $P_{M2} = 19.9$ dBm.

4.2.7.6 Test of Centre Frequency and Frequency Deviation

This test shall verify Centre Frequency and Frequency Deviation.

The proposed test set-up is according to Figure 25 on page 72. Test cases are according to sub-clause 4.2.7.16.2 on page 86.

Measure the carrier amplitude and phase of the Up-link signal over a 1 ms time frame. A bandwidth of more than 2 MHz shall be used, and it is recommended that 8 MHz should be used to avoid errors due to spectrum truncation.

1. Evaluate Up-link frequency during the measured period, determining the times during which “0” (f_L) respectively “1” (f_H) are transmitted.
2. Apply a window, 16 bits long, to the first 16 bits of the measured data.
3. For the bits within the window, find the average frequency for each bit.
4. For the bits within the window, find the minimum and maximum value of the average frequencies of the “0” (f_L) bits, f_{Lmin} and f_{Lmax} . In the same manner, find the minimum and maximum value of the average frequencies of the “1” (f_H) bits, f_{Hmin} and f_{Hmax} .
5. Evaluate “Centre frequency” respectively “Deviation” according to “ $(f_L+f_H)/2 = 4.234 \text{ MHz} \pm 175 \text{ kHz}$ ” respectively “ $(f_H-f_L)/2 = 282.24 \text{ kHz} \pm 7 \%$ ”, using the worst case combinations of f_{Lmin} and f_{Lmax} respectively f_{Hmin} and f_{Hmax} . This means that:
 - $(f_{Lmax}+f_{Hmax})/2 < 4.234 \text{ MHz} + 175 \text{ kHz} = 4.409 \text{ MHz}$
 - $(f_{Lmin}+f_{Hmin})/2 > 4.234 \text{ MHz} - 175 \text{ kHz} = 4.059 \text{ MHz}$
 - $(f_{Hmax}-f_{Lmin})/2 < 282.24 \text{ kHz} + 7 \% = 302.00 \text{ kHz}$
 - $(f_{Hmin}-f_{Lmax})/2 > 282.24 \text{ kHz} - 7 \% = 262.48 \text{ kHz}$
6. Step the window forward 1 bit through the measured data.
7. Repeat steps 3 through 6 until the end of the measured data is reached.

A time period of not more than the time equivalent to one period of the carrier (236 ns) should be ignored around the bit transition.

4.2.7.7 Test of Start-up after Side Lobe

This test shall verify Centre Frequency and Frequency Deviation for start-up after a preceding side lobe.

The proposed test set-up is according to Figure 25 on page 72. Test cases are according to sub-clause 4.2.7.16.3 on page 86.

The test shall be performed according to sub-clause 4.2.7.6, but with an extra burst of 27 MHz signal preceding the one used for the test:

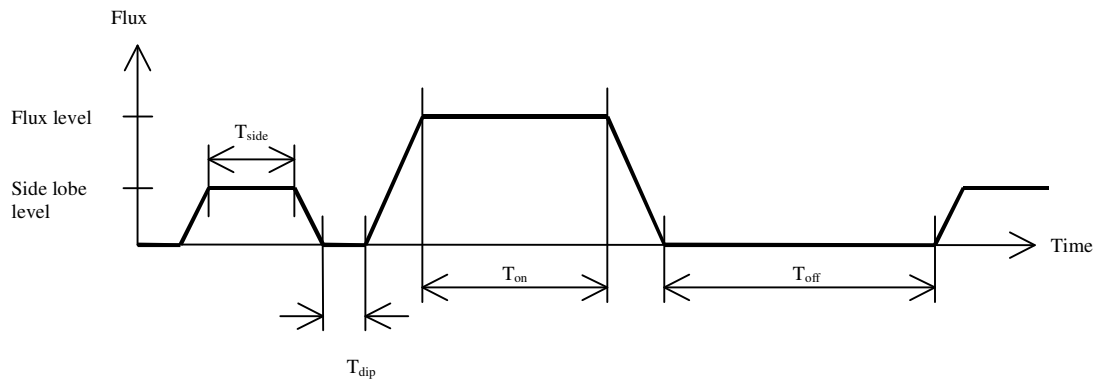

Figure 30: Simulated train passage with side lobe

The flux level for the side lobe (“Side lobe level”) shall be 17 dB below that of the main lobe (“Flux level”).

The timing of the side lobe shall be $T_{\text{side}} = 1 \text{ ms}$, $T_{\text{dip}} = 25 \text{ }\mu\text{s}$. The start-up and end ramps shall have the same slope as those for the main lobe.

4.2.7.8 Test of Mean Data Rate

The proposed test set-up is according to Figure 25 on page 72. Test cases are according to sub-clause 4.2.7.16.4 on page 87.

The analyser shall be configured for measuring demodulated FSK over 1500 symbols with a resolution of 4 samples/symbol. A bandwidth of 8 MHz should be used to avoid errors due to spectrum truncation.

The mean data rate is defined as $\frac{1500}{T(\text{bit}_{1500}) - T(\text{bit}_0)}$.

When the exact timing of bit_0 or bit_{1500} can not be determined from measurement data due to a sequence of consecutive ‘0’ or ‘1’, the timing of these bit transitions shall be calculated through linear interpolation between the timing of the closest bit transitions, where this can be determined from measurement data.

The mean data rate shall be $564.48 \text{ kbit/s} \pm 2.5 \%$.

4.2.7.9 Test of MTIE (Maximum Time Interval Error)

The proposed test set-up is according to Figure 25 on page 72. Test cases are according to sub-clause 4.2.7.16.5 on page 87.

The analyser shall be configured for measuring carrier amplitude and phase over at least 1500 bits. A bandwidth of 8 MHz should be used to avoid errors due to spectrum truncation.

The actual signal timing of the bits shall be evaluated for the measured data. The measurement method shall be based on phase demodulation of the Up-link signal performed in a sufficient amount of points during a one bit window, evaluation of the best linear fit of these phase samples (linear regression) during the bit window, identification of the exact instants of bit transition, evaluation of the overall time interval error considering the combination of data rate and carrier phase errors, and a verification of the MTIE1 or MTIE2 requirements. The bit transitions are defined as where the two best fit lines of successive “one” and “zero” (or “zero” and “one”) bits meet. In the event of many successive “ones” or “zeroes”, the distance between discernible bit transitions is split into a suitable amount of equally long bits, and consequently the overall time interval error is assigned (split) in equal parts to the same number of bits.

The data shall comply with either MTIE1 requirement or MTIE2 requirement according to UNISIG SUBSET-036. This shall be verified for all possible 1000 bit windows in the measurement data. It shall also be verified that the mean data rate calculated according to the formula given in sub-clause 4.2.7.8 complies with the requirement given there for all possible 1500 bit windows in the measurement data.

If the MTIE2 requirement is chosen, the “mean data rate” referred to in the requirement shall be derived from the same set of measurement data as the bit timings.

4.2.7.10 Test of Amplitude Jitter during start-up ramp

The proposed test set-up is according to Figure 25 on page 72. Test cases are according to sub-clause 4.2.7.16.6 on page 88.

The analyser shall be configured for measuring carrier amplitude and phase over a time sufficient to cover the entire start-up ramp of the 27 MHz signal. A bandwidth of 4 MHz shall be used to avoid errors due to spectrum truncation.

As an alternative to using the Vector Signal Analyser included in the test set-up according to Figure 25 on page 72, direct sampling and digitising may be performed if it can be proven that the related software algorithms required for analysis of the acquired data gives the same end results. The sampling rate should be at least 100 MHz, and the amplitude resolution should be at least 12 bits.

A sliding 50 μ s to 100 μ s wide window shall be defined in the measured data. Initially the window shall start 150 μ s after the passage of the ϕ_{d1} flux level if Tele-powering is CW, and 250 μ s after the passage of the ϕ_{d1} flux level if Tele-powering is toggling.

The average (RMS) amplitude value shall be evaluated over a 1.77 μ s long interval at the centre of the sliding window. The amplitude jitter shall be defined as the difference between this RMS value over the centre interval and the average¹⁵ amplitude value over the entire sliding window.

The amplitude jitter shall be less than +1.5/-2.0 dB for all positions of the sliding window.

¹⁵ Either true RMS average or arithmetic average of the demodulated sine amplitude (normalised to RMS value) is allowed for the longer window.

4.2.7.11 Test of Amplitude Jitter during steady state flux

The proposed test set-up is according to Figure 25 on page 72. Test cases are according to sub-clause 4.2.7.16.7 on page 88.

The analyser shall be configured for measuring carrier amplitude and phase over a period of 20 ms. A bandwidth of 4 MHz shall be used to avoid errors due to spectrum truncation.

As an alternative to using the Vector Signal Analyser included in the test set-up according to Figure 23 on page 67, direct sampling and digitising may be performed if it can be proven that the related software algorithms required for analysis of the acquired data is in correspondence with the specification. The sampling rate should be at least 100 MHz, and the amplitude resolution should be at least 12 bits.

A sliding 400 μ s to 800 μ s wide window shall be defined in the measured data. Initially the window shall start at a time when steady state conditions have occurred for input flux.

The average (RMS) amplitude value shall be evaluated over a 1.77 μ s long window at the centre of the sliding window. The amplitude jitter shall be defined as the difference between this RMS value over the centre interval and the average¹⁶ amplitude value over the entire sliding window.

The amplitude jitter shall be less than +1.5/-2.0 dB for all positions of the sliding window.

4.2.7.12 Test of Signal Bandwidth

The proposed test set-up is according to Figure 25 on page 72. Test cases are according to sub-clause 4.2.7.16.8 on page 89.

The 10 dB signal bandwidth shall be measured directly with the analyser in the spectrum analyser mode and shall be less than 1 MHz.

In a first step, the signal power shall be measured in a 1 MHz wide band centred around the already determined centre frequency. This shall be performed through evaluation of the RMS averaged spectrum of the signal, using a Resolution Bandwidth of approximately 4.8 kHz, a Span of 4 MHz (corresponding to a signal record length of 800 μ s), and an averaging factor of 10. The signal power shall then be obtained by integration of this spectrum within the above defined 1 MHz band. Thereafter, the same process shall be repeated, but with the 1 MHz window centred respectively 1 MHz above, and 1 MHz below, the already determined centre frequency. The sum of the signal power within the latter two 1 MHz windows shall be at least 10 dB below the signal power of the 1 MHz window that was centred around the centre frequency (the first measurement).

4.2.7.13 Test of Delay Time and Balise controlling interface Parameter Variation

The proposed test set-up is according to Figure 25 on page 72. Test cases are according to sub-clause 4.2.7.16.9 on page 89.

The test shall verify that the Balise functions correctly, and that the delay of the signal from the Balise controlling interface to the Interface 'A' is less than 10 μ s for the specified conditions of the input signal on the Balise controlling interface defined in sub-clause 4.2.7.16.9 on page 89.

The start of the telegram sent from the Reference Signal Generator to the Balise controlling interface shall be indicated by the trigger output signal from the Reference Signal Generator. The received telegram shall be analysed, and the delay of the signal between the two interfaces shall be evaluated. It shall also be verified that the whole sent telegram has been received correctly.

¹⁶ Either true RMS average or arithmetic average of the demodulated sine amplitude (normalised to RMS value) is allowed for the longer window.

4.2.7.14 Test of Compatibility

The proposed test set-up is according to Figure 25 on page 72. Test cases are according to sub-clause 4.2.7.16.10 on page 89.

It shall be verified that for a “Non-toggling AM” 27 MHz input Tele-powering signal, the Balise does not transmit an Up-link signal for a longer period of time than 80 μ s.

4.2.7.15 Test of Balise start with Toggling AM and steep Tele-powering slope

The proposed test set-up is according to Figure 25 on page 72. Test cases are according to sub-clause 4.2.7.16.11 on page 89.

It shall be verified that for a “Toggling AM” 27 MHz input Tele-powering signal with steep Tele-powering slope, the Balise starts each time a simulated train passage is performed. For each simulated passage, verify that the Balise starts no later than 250 μ s after the passage of the flux level ϕ_{d1} (for the purpose of this test, through verifying that the Up-link signal level exceeds I_{u1}). Measurement tolerances shall be considered when selecting the actual test limits.

4.2.7.16 Test Matrices

4.2.7.16.1 General

The following test matrices define the applicable test cases. See also sub-clauses 4.2.7.2 on page 73 and 4.2.7.3 on page 76, i.e., sub-clause 4.2.7.4 on page 77 only applies where explicitly stated.

Unless otherwise explicitly stated, all conditions are nominal in the herein defined test matrices.

4.2.7.16.2 Centre Frequency and Frequency Deviation

Measurements shall be done after a start-up ramp according to sub-clause 4.2.7.2.3 on page 73.

Measurements during nominal conditions shall be performed for all flux levels according to Table 1 on page 75. For other conditions, only flux level 3 applies.

The following combinations of Test Conditions and Telegrams shall be tested:

Test Condition	Telegram Type 4	Telegram Type 5
Nominal	X	X
Lower temperature limit	X	
Upper temperature limit	X	
Metallic Plate	X	
Steel Sleeper	X	
Salt Water	X	
Clear Water	X	
Iron Ore	X	

Table 3: Test Conditions versus Telegrams for Centre Frequency and Frequency Deviation

4.2.7.16.3 Start-up after Side Lobe

Measurements shall be performed for all flux levels according to Table 1 on page 75.

The following combinations of Test Conditions and Telegrams shall be tested:

Test Condition	Telegram Type 4	Telegram Type 5
Nominal	X	X

Table 4: Test Conditions versus Telegrams for Start-up after Side Lobe

4.2.7.16.4 Mean Data Rate

Measurements shall start at least 10 ms after the 27 MHz Tele-powering flux has reached the level ϕ_{d1} on a start-up ramp according to sub-clause 4.2.7.2.3 on page 73.

Measurements shall be performed for flux level 3 according to Table 1 on page 75.

The following combinations of Test Conditions and Telegrams shall be tested:

Test Condition	Telegram Type 2	Telegram Type 3	Telegram Type 5
Nominal	X	X	X
Metallic Plate		X	
Steel Sleeper		X	
Salt Water		X	
Clear Water		X	
Iron Ore		X	

Table 5: Test Conditions versus Telegrams for Mean Data Rate

4.2.7.16.5 MTIE (Maximum Time Interval Error)

Measurements shall be done after a start-up ramp according to sub-clause 4.2.7.2.3 on page 73.

Measurements shall be performed for flux level 3 according to Table 1 on page 75.

The following combinations of Test Conditions and Telegrams shall be tested:

Test Condition	Telegram Type 1	Telegram Type 2	Telegram Type 3	Telegram Type 4	Telegram Type 5
Nominal	X	X	X	X	X
Lower temperature limit			X		
Upper temperature limit			X		
Metallic Plate			X		
Steel Sleeper			X		
Salt Water			X		
Clear Water			X		
Iron Ore			X		

Table 6: Test Conditions versus Telegrams for MTIE

4.2.7.16.6 Amplitude Jitter during start-up ramp

Measurements shall be performed with 'CW' Tele-powering only, and for flux level 3 according to Table 1 on page 75.

The following combinations of Test Conditions and Telegrams shall be tested:

Test Condition	Telegram Type 1	Telegram Type 5
Nominal	X	X
Metallic Plate	X	
Steel Sleeper	X	
Salt Water	X	
Clear Water	X	
Iron Ore	X	

Table 7: Test Conditions versus Telegrams for Amplitude Jitter

4.2.7.16.7 Amplitude Jitter during steady state flux

Measurements shall be performed for all Tele-powering flux levels according to Table 1 on page 75.

A start-up ramp according to sub-clause 4.2.7.2.3 on page 73 is not applicable.

The following combinations of Test Conditions and Telegrams shall be tested:

Test Condition	Telegram Type 1	Telegram Type 5
Nominal	X	X
Metallic Plate	X	
Steel Sleeper	X	
Salt Water	X	
Clear Water	X	
Iron Ore	X	

Table 8: Test Conditions versus Telegrams for Amplitude Jitter

4.2.7.16.8 Signal Bandwidth

Measurements shall be performed with 'CW' Tele-powering only, at flux level 3 (according to Table 1 on page 75), and with telegram type 1 only.

A start-up ramp according to sub-clause 4.2.7.2.3 on page 73 is not applicable.

For controlled Balises, this test shall be performed with the Reference Signal Generator enabled only.

4.2.7.16.9 Delay Time and Balise controlling interface Parameter Variation

This test is applicable to controlled Balises only, and shall be performed with a Reference Signal Generator connected ("enabled Reference Signal Generator").

Measurements shall be performed with 'CW' Tele-powering only, at flux level 3 (according to Table 1 on page 75), and with telegram type 1 only.

A start-up ramp according to sub-clause 4.2.7.2.3 on page 73 is not applicable.

The signals in the Balise controlling interface shall have their parameter values set to the nominal values according to sub-clause 4.2.8.3 on page 91, except for Interface 'C1' and Interface 'C6' signal levels that shall be set to their defined minimum values.

4.2.7.16.10 Compatibility

Measurements shall be performed with 'Non-toggling AM' Tele-powering only, at flux level 3 (according to Table 1 on page 75), and with telegram type 1 only.

This test shall be performed with start-up and end ramps at slopes that are 1/1000 of the nominal slopes defined in sub-clause 4.2.7.2.3 on page 73, and at the nominal slopes defined in sub-clause 4.2.7.2.3 on page 73. The requirement on duty cycle according to sub-clause 4.2.7.2.3 on page 73 is not applicable to this measurement (it is of a one-shot nature).

Measurements shall start in the window from the start of the ramp to the flux level reaching $\phi_{d1} - 10$ dB.

Measurements at the modulation depth 52 % \pm 2 % shall be performed with a modulation pulse width of 2.1 μ s \pm 0.1 μ s, and measurements at the modulation depth 85 % to 100 % shall be performed with a modulation pulse width of 3.4 μ s \pm 0.1 μ s. In order to consider the possibility of a certain amount of toggling (as opposed to random jitter that might contain a pattern similar to toggling), the test with short pulses shall be performed with toggling pulse widths of 2.1 μ s and 2.2 μ s, and the test with long pulses shall be performed with toggling pulse widths of 3.3 μ s and 3.4 μ s. This allows for additional \pm 0.05 μ s random jitter that is caused by imperfections in the test set-up.

4.2.7.16.11 Test of Balise start with Toggling AM and steep Tele-powering slope

Measurements shall be performed with 'Toggling AM' Tele-powering conditions in accordance with the definitions of sub-clause 4.2.7.4 on page 77.

A total of eight combinations of modulation pulse rise and fall times, modulation depth, and slope of Tele-powering flux shall be tested.

Two hundred and fifty consecutive simulated train passages shall be performed for each test case, and the Balise shall start each time.

4.2.8 Balise controlling interface performance measurements

4.2.8.1 Introduction

This sub-clause defines the measurement methods for verifying Up-link FSK performance versus the Balise controlling interface performance, and the Balise controlling interface performance of the Up-link controlled Balise.

Measurements of FSK Up-link performance are defined in sub-clause 4.2.7 on page 72.

For the purpose of testing, the source impedance of the tool generating the Interface 'C' signals should provide a minimum Return Loss of 23 dB unless otherwise explicitly stated.

4.2.8.2 General Test Conditions

4.2.8.2.1 General

The following conditions apply for all measurements unless nothing else is indicated.

4.2.8.2.2 Climatic Conditions

Ambient Temperature	25 °C ± 10 °C
Relative Humidity	25 % to 75 %
Atmospheric Pressure	86 kPa to 106 kPa

4.2.8.2.3 Metallic Object and Debris

No metallic objects shall be present.

No debris shall be applied.

4.2.8.2.4 Test Distance

The vertical distance between the Test Antenna and the Balise shall be 220 mm ±2 mm from the centre of the Test Antenna loop to the reference marks of the Balise or the Reference Loop.

4.2.8.2.5 Tele-powering Flux Characteristics

The Tele-powering flux shall have the following characteristics:

- The frequency shall be 27.095 MHz ± 5 kHz.
- The signal shall be CW, i.e., without modulation.
- Additionally (for some specific tests) the flux shall also be modulated to simulate a train passage according to sub-clause 4.2.7.2.3 on page 73.

Transient measurements shall start 150 µs after the 27 MHz flux has reached the level ϕ_{d1} on the start up ramp. The transient measurements are performed for "blocking Up-link telegram switching" (see sub-clause 4.2.8.5.6 on page 106).

For the following tests, the Tele-powering flux shall be calibrated at three different levels:

Level	Value
1	$\phi_{d1} + 0.8 \text{ dB} \pm 0.5 \text{ dB}$
2	$\phi_{d2} + 10 \text{ dB} \pm 1 \text{ dB}$
3	$\phi_{d4} - 1 \text{ dB} \pm 1 \text{ dB}$

Table 9 : Tele-powering Flux Levels

4.2.8.2.6 Telegram Contents

For the purpose of the tests, the Balise shall transmit a valid randomised 341 bits telegram (i.e., fulfilling the coding requirements of UNISIG SUBSET-036). This telegram shall be of types 1 through 5 of Table 24 in clause A2 on page 161.

4.2.8.3 Electrical Data Requirements

4.2.8.3.1 Interface 'A1'

The electrical characteristics of the signal in the Interface 'A1' are summarised in Table 10 below.

Characteristics	Nominal value	Tolerance range	Notes
Modulation	FSK		
Centre frequency	4.234 MHz	$\pm 175 \text{ kHz}$	See sub-clause 4.2.7.6 on page 81.
Frequency deviation	282.24 kHz	$\pm 7 \%$	See sub-clause 4.2.7.6 on page 81.
Bandwidth	< 1 MHz		See sub-clause 4.2.7.12 on page 84.
Amplitude jitter	< +1.5/-2.0 dB		See sub-clause 4.2.7.11 on page 84.
Mean data rate	564.48 kbits/s	$\pm 2.5 \%$	See sub-clause 4.2.7.8 on page 82.
MTIE (and carrier phase jitter)	MTIE1 or MTIE2		See sub-clause 4.2.7.9 on page 83.

Table 10: Electrical characteristics of the Interface 'A1' Up-link signal

4.2.8.3.2 Interface 'C1'

The electrical characteristics of the signal in the Interface 'C1' are summarised in Table 11 below (referring to the LEU output).

Characteristics	Nominal value	Tolerance range	Notes
Signal level V_2	> 14 Vpp		Into a resistive 120 Ω load
Signal level V_2	< 18 Vpp		Into a resistive 120 Ω load
Waveform and bit encoding	DBPL		
Mean Data Rate	564.48 kbits/s	± 200 ppm	Averaged over 1500 consecutive bits
Time Jitter	< 60 ns		
Rise Time 10 % to 90 %	> 100 ns		
Return Loss (at LEU output)	> 6 dB		With reference to 120 Ω

Table 11: Electrical characteristics of the Interface 'C1' Up-link signal

The signal into a resistive 120 Ω load shall also fulfil the requirements according to Figure 31 and Table 12 below. The shaded areas constitute a mask into which the signal shall not enter (considering the actual mean data rate and the actual V_2 signal level).

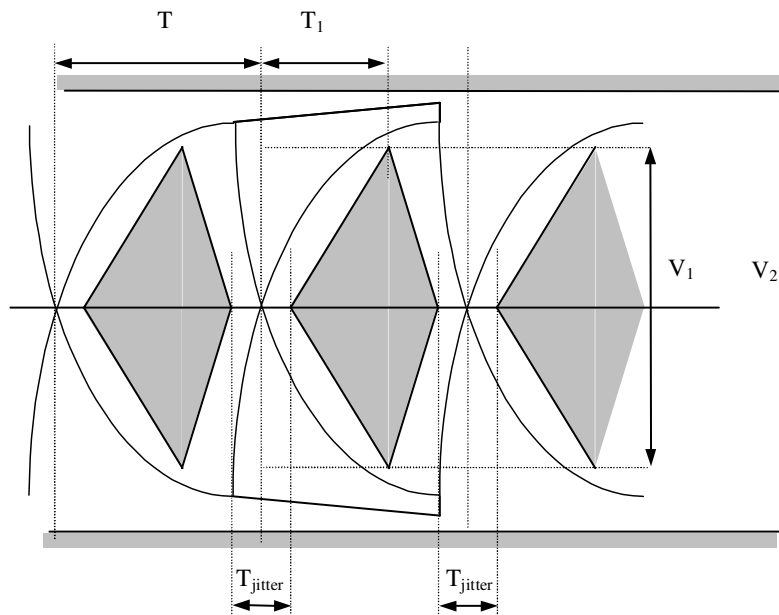

Figure 31: Interface 'C1' eye diagram

Parameter	Requirement at the LEU output
T	$\frac{1}{2 \bullet \text{actual Mean Data Rate}}$
T _{jitter}	60 ns
T ₁	0.6 • T
V ₁	0.74 • V ₂

Table 12: Interface ‘C1’ eye diagram parameters

The test of the characteristics for the eye diagram, shall be performed with a waveform forming an exponential signal with the following characteristic equation:

$$\left\{ \begin{array}{l} V_{\text{out}} = \frac{1}{2} \left[-1.87 \cdot V_2 \cdot e^{-\frac{t}{\tau}} + V_2 \right] \text{ , rising edge} \\ V_{\text{out}} = \frac{1}{2} \left[1.87 \cdot V_2 \cdot e^{-\frac{t}{\tau}} - V_2 \right] \text{ , falling edge} \end{array} \right.$$

with:

V_{out} and V₂ in Volt

τ = 332.3 ns unless otherwise explicitly stated. For test purposes, the acceptable range is 330 ns ±30 ns

For the purpose of adjusting the V₂ signal level during testing, the connected load impedance shall be 120 Ω ±1 Ω resistive, with a maximum imaginary part of ±j1 Ω.

Please observe that the value 1.87 applies to the theoretical time constant 332.3 ns, and that this must be suitably modified when other time constants apply, such that a continuous signal is still obtained.

4.2.8.3.3 Interface 'C6'

The electrical characteristics of the signal in the Interface 'C6' are summarised in Table 13 below (referring to the LEU output).

Characteristics	Nominal value	Tolerance range	Notes
Nominal value	22 Vpp	+1 V / -2 V	Into a resistive 170 Ω load
Waveform	Sinusoidal		
Frequency	8.820 kHz	± 0.1 kHz	
Second harmonic amplitude	< -20 dBc		
Harmonic content	< -40 dBc		Between 0.1 MHz and 1 MHz into a restive 120 Ω load impedance
Return Loss (at LEU output)	> 4 dB		With reference to 170 Ω

Table 13: Electrical characteristics of the Interface 'C6' signal

For the purpose of adjusting the peak to peak voltage during testing, the connected load impedance shall be 170 $\Omega \pm 1 \Omega$ resistive, with a maximum imaginary part of $\pm j1 \Omega$.

4.2.8.3.4 Interface 'C4'

Blocking of Up-link telegram switching is an optional function. The signal on Interface 'C4' shall fulfil the diagrams of Figure 32 below. Data and characteristics refer to the Balise itself (excluding the Interface 'C' cable).

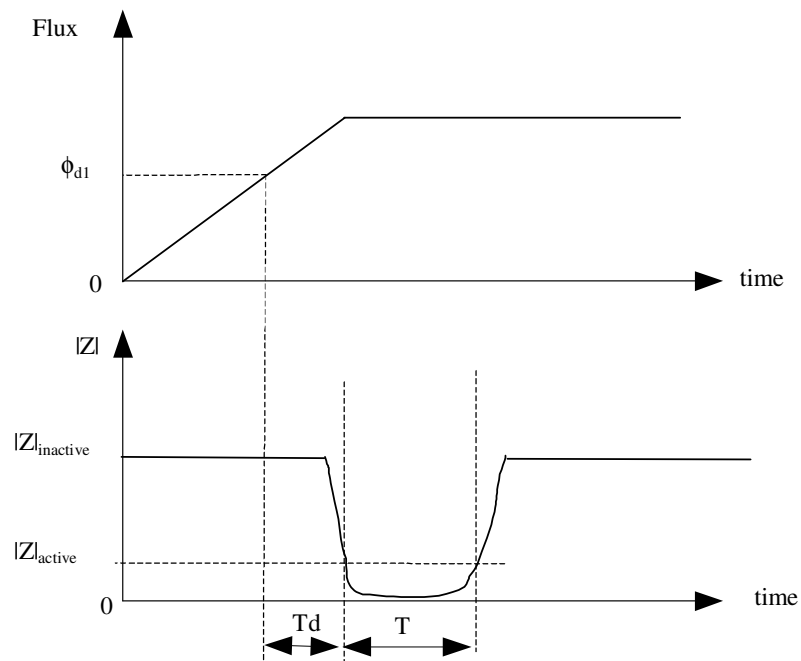

Figure 32: Signal on Interface 'C4'

The characteristics of this signal are summarised in Table 14 below.

Characteristics	Min.	Max.
$ Z _{\text{inactive}} [\Omega]$	150	300
$ Z _{\text{active}} [\Omega]$		$0.1 \cdot Z _{\text{inactive}}$
T [μs]	150	350
Td [μs]		150

Table 14: Characteristics of the Interface 'C4' signal

Please observe that T_d is allowed to be negative as defined above, because the Balise is allowed to start earlier than at the ϕ_{d1} level.

The modulus of the impedance shall be evaluated over the frequency range 8.720 kHz to 8.920 kHz.

4.2.8.4 Calibration of the 27 MHz Tele-powering flux

4.2.8.4.1 Calibration Abstract

This calibration procedure only deals with constant level of the 27 MHz Tele-powering flux, and not with a ramping flux simulating a train passage. It gives a reference value P27BA that is used when activating the Balise with flux levels according to Table 9 on page 91 through the Reference Area.

4.2.8.4.2 Calibration Configuration

The recommended calibration set-up is shown in Figure 33 below. Clause F1 of Annex F on page 297 gives an example of suitable test equipment. See also sub-clause 4.2.1 on page 23.

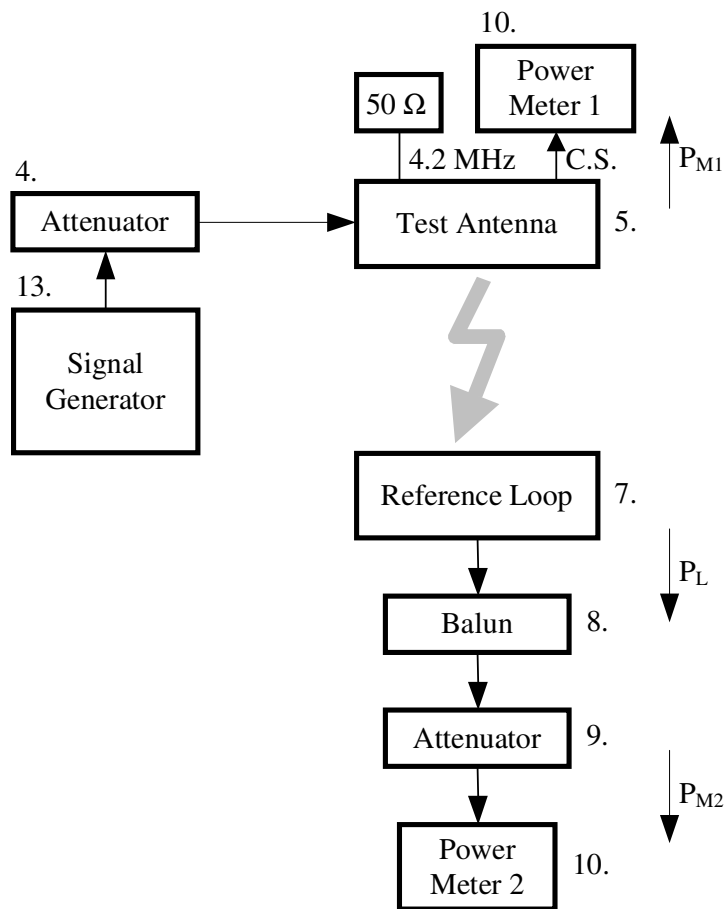

Figure 33: Test set-up for calibration of Tele-powering

4.2.8.4.3 Calibration Procedure

1. Position the (Standard) Test Antenna in position [X = 0, Y = 0, Z = 220] relative to the Reference Loop. Be sure to position the electrical centre of the Test Antenna aligned with the electrical centre of the Reference Loop. Also check that the X, Y and Z axes of the Reference Loop are correctly aligned to the X, Y and Z axes of the positioning system.
2. Determine a suitable power level, P_{M2} , for a flux of $\phi_{d1} + 0.8$ dB (one of the values from Table 9 on page 91). The power for ϕ , P_L , is determined by

$$P_L = \frac{(2 \cdot \pi \cdot f \cdot \Phi)^2}{50 \cdot \left(\frac{|50 + Z_{loop}|}{50} \right)^2 \cdot B^2}$$

where :

$f = 27.095$ MHz,

$Z_{loop} = R_{loop} + j X_{loop}$ (actual impedance in the absence of any antenna),

P_L = Power measured out of the Reference Loop [W],

B = Reference Loop matching transfer ratio.

The power for ϕ , P_{M2} , is determined by:

$$P_{M2} = 10 \cdot \log(1000 \cdot P_L) - \text{Attenuation (dBm)}$$

where *Attenuation* equals the attenuation of the items 8 and 9 together with the cable from the Reference Loop to the power sensor head.¹⁷

Measure Attenuation, and calculate the value of P_{M2} . Call the calculated value P_{M2REF} .

4. Set the Signal Generator to the frequency 27.095 MHz, and to CW.
5. Adjust the input power to the Test Antenna in order to achieve approximately $\phi_{d1} + 0.8$ dB through the Reference Loop (through observing Power Meter 2).

Record the reading of Power Meter 2 (called P_{M2}). Record the reading of Power Meter 1 (called P_{M1}).

6. Compensate the P_{M1} reading with the difference between the P_{M2} reading and the power level P_{M2REF} calculated in step 3¹⁸. Call the new value P_{27RL} .

$$P_{27RL} = P_{M1} + (P_{M2REF} - P_{M2}), \text{ all values in dBm.}$$

7. Repeat steps 2 to 6 for all flux levels in Table 9 on page 91.

¹⁷ As an example, assuming that Z_{loop} is small compared to 50 Ω , $\phi_{d1} + 0.8$ dB = 8.5 nVs, $B = 1$ and Attenuation = 20 dB, then the power level P_{M2} will be -3.8 dBm in the Reference Loop. For the Reduced Size Reference Loop, the corresponding value for $\phi_{d1} + 0.8$ dB = 5.7 nVs is -7.2 dBm.

¹⁸ The reason for this compensation is that the relative accuracy for the value of P_{27RL} between the different positions needs to be very good, and this procedure compensates for signal generator adjustment error.

4.2.8.5 Functional Tests

4.2.8.5.1 Test Set-up

The recommended test set-up is shown in Figure 34 below. Clause F1 of Annex F on page 297 gives an example of suitable test equipment. See also sub-clause 4.2.1 on page 23.

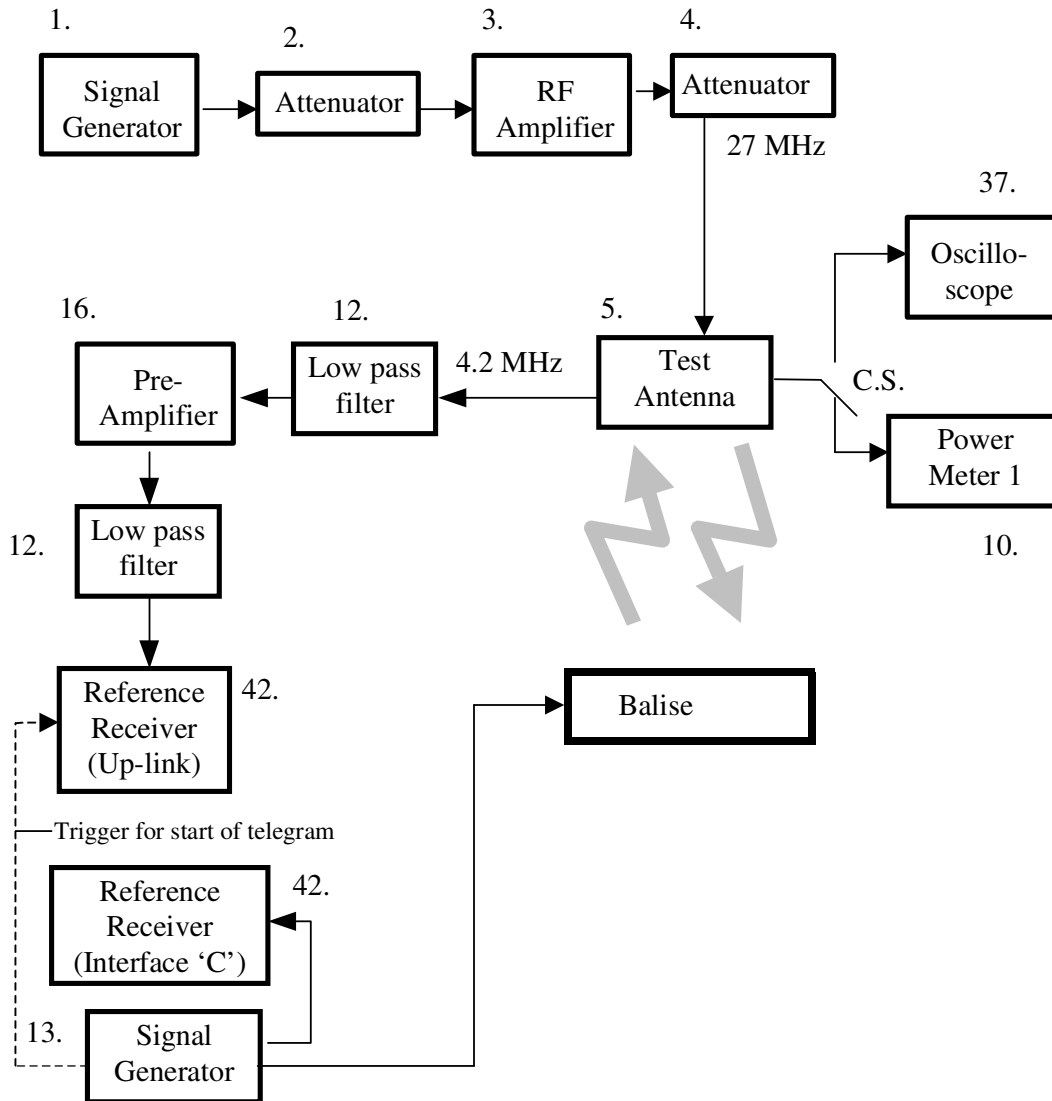

Figure 34: Test set-up for Up-link measurements

4.2.8.5.2 Electrical Data versus Signal Level

4.2.8.5.2.1 Test Abstract

This test verifies that the Balise transmission characteristics on the Interface 'A1' are within the allowed tolerance ranges when the signals on the Interface 'C1' and Interface 'C6' are set at the limit of the defined signal level ranges. See sub-clause 4.2.8.3.2 on page 92, and sub-clause 4.2.8.3.3 on page 94. For the purpose of this test, the edges of the Interface 'C1' signal shall be such that testing is performed both with $\tau = 100 \text{ ns} + 10/-0 \text{ ns}$ and $\tau = 330 \text{ ns} \pm 30 \text{ ns}$.

4.2.8.5.2.2 Test Procedure

1. Position the Test Antenna in position [X = 0, Y = 0, Z = 220].
2. Set the Signal Generator (item 1) to the frequency 27.095 MHz, and to CW.
3. Adjust the input power to the Test Antenna in order to achieve approximately $\phi_{d1} + 0.8 \text{ dB}$ through the Balise. This is accomplished when the reading of the Power Meter 1 is equal to P_{27RL} measured in sub-clause 4.2.8.4.3 on page 97.
4. Set the Interface 'C' signal generator (item 13) to the following configuration:

Interface 'C1'	Level (Vpp)	following C1 test level (Table 15 on page 100)
	Mean Data Rate	564.48 kbits/s \pm 40 ppm
	Telegram	type 1, without jitter
Interface 'C6'	Level (Vpp)	following C6 test level (Table 16 on page 100)
	Frequency	8.820 kHz \pm 0.01 kHz

5. Check with the reference receiver for Up-link (item 42) that:
 - The Balise transmits the selected telegram.
 - The centre frequency, frequency deviation, mean data rate, and MTIE are within the required range (see Table 10 on page 91).
6. Perform steps 3 through 5 for all the configurations listed in sub-clause 4.2.8.5.2.4 on page 100.

4.2.8.5.2.3 Test Signal Level Definition

Level at the LEU output	
Minimum level (Vpp)	Maximum level (Vpp)
$V_2 = 14 \text{ V } +0.25/-0 \text{ V}$	$V_2 = 18 \text{ V } +0/-0.25 \text{ V}$

Table 15: Definition of the Interface 'C1' signal levels

Level at the LEU output	
Minimum level (Vpp)	Maximum level (Vpp)
$20 \text{ V } +0.3/-0 \text{ V}$	$23 \text{ V } +0/-0.3 \text{ V}$

Table 16: Definition of the Interface 'C6' signal levels

4.2.8.5.2.4 Test Matrix

Flux Level	Interface 'C1' level		Interface 'C6' level		Slope [ns]
	Min.	Max.	Min.	Max.	
1		X		X	100
1	X		X		100
1		X		X	330
1	X		X		330
2		X		X	100
2	X		X		100
2		X		X	330
2	X		X		330
3		X		X	100
3	X		X		100
3		X		X	330
3	X		X		330

Table 17: Test conditions versus signal level on Interface 'C1' and 'C6' at LEU output

4.2.8.5.3 Electrical Data versus Mean Data Rate

4.2.8.5.3.1 Test Abstract

This test verifies that the Balise transmission characteristics on the Interface 'A1' are within the tolerance ranges when the mean data rate of the signal on the Interface 'C1' is altered over the specified range (see sub-clause 4.2.8.3.2 on page 92). For the purpose of this test, the edges of the Interface 'C1' signal shall be such that testing is performed both with $\tau = 100 \text{ ns} +10/-0 \text{ ns}$ and $\tau = 330 \text{ ns} \pm 30 \text{ ns}$.

4.2.8.5.3.2 Test Procedure

1. Position the Test Antenna in position [X = 0, Y = 0, Z = 220].
2. Set the Signal Generator (item 1) to the frequency 27.095 MHz, and to CW.
3. Adjust the input power to the Test Antenna in order to achieve approximately $\phi_{d1} +0.8 \text{ dB}$ through the Balise. This is accomplished when the reading of the Power Meter 1 is equal to P_{27RL} measured in sub-clause 4.2.8.4.3 on page 97.
4. Set the Interface 'C' signal generator (item 13) to the following configuration:

Interface 'C1'	Level (Vpp)	$V_2 = 14 \text{ V} +0.25/-0 \text{ V}$
	Mean Data Rate	sub-clause 4.2.8.5.3.3 on page 102
	Telegram	type 1, without jitter
Interface 'C6'	Level (Vpp)	$20 \text{ V} +0.3/-0 \text{ V}$
	Frequency	$8.820 \text{ kHz} \pm 0.01 \text{ kHz}$

5. Check with the reference receiver for Up-link (item 42) that:
 - The Balise transmits the selected telegram.
 - The centre frequency, frequency deviation, mean data rate, and MTIE are within the required range (see Table 10 on page 91).
6. Perform steps 3 through 5 for all the configurations listed in sub-clause 4.2.8.5.3.3 on page 102.

4.2.8.5.3.3 Test Matrix

Flux Level	Mean data rate		Slope [ns]
	564.38 kbits/s +40/-0 ppm	564.58 kbits/s +0/-40 ppm	
1	X		100
1		X	100
1	X		330
1		X	330
2	X		100
2		X	100
2	X		330
2		X	330
3	X		100
3		X	100
3	X		330
3		X	330

Table 18: Test conditions versus mean data rate on Interface 'C1'

4.2.8.5.4 Electrical Data versus Jitter Properties

4.2.8.5.4.1 Test Abstract

This test verifies that the Balise transmission characteristics on the Interface 'A1' are within the tolerance range when the signal on the Interface 'C1' is within the defined eye diagram (see sub-clause 4.2.8.3.2 on page 92). For the purpose of this test, the edges of the Interface 'C1' signal shall be such that testing is performed both with $\tau = 100 \text{ ns } +10/-0 \text{ ns}$ and $\tau = 330 \text{ ns } \pm 30 \text{ ns}$.

4.2.8.5.4.2 Test Procedure

1. Position the Test Antenna in position [X = 0, Y = 0, Z = 220].
2. Set the Signal Generator (item 1) to the frequency 27.095 MHz, and to CW.
3. Adjust the input power to the Test Antenna in order to achieve approximately $\phi_{d1} +0.8 \text{ dB}$ through the Balise. This is accomplished when the reading of the Power Meter 1 is equal to P_{27RL} measured in sub-clause 4.2.8.4.3 on page 97.
4. Set the Interface 'C' signal generator (item 13) to the following configuration:

Interface 'C1'	Level (Vpp)	$V_2 = 14 \text{ V } +0.25/-0 \text{ V}$
	Mean Data Rate	$564.48 \text{ kbits/s } \pm 40 \text{ ppm}$
	Telegram	type 4, jitter 60 ns
Interface 'C6'	Level (Vpp)	$20 \text{ V } +0.3/-0 \text{ V}$
	Frequency	$8.820 \text{ kHz } \pm 0.01 \text{ kHz}$

Considering the initial DBPL coded message with the required mean data rate, a time jitter is randomly applied to each edge of this signal. The time jitter can vary from -30 ns to $+30 \text{ ns}$ (see Table 12 on page 93).

5. Check with the reference receiver for Up-link (item 42) that:
 - The Balise transmits the selected telegram.
 - The centre frequency, frequency deviation, mean data rate, and MTIE are within the required range (see Table 10 on page 91).
6. Perform steps 3 through 5 for all Tele-powering flux levels defined in Table 9 on page 91.

4.2.8.5.4.3 Test Matrix

Tests shall be performed both with $\tau = 100 \text{ ns } +10/-0 \text{ ns}$ and $\tau = 330 \text{ ns } \pm 30 \text{ ns}$.

4.2.8.5.5 Balise Testing under various Return Loss conditions

4.2.8.5.5.1 Test Abstract

This test shall verify that the Balise and its Interface 'C' cable correctly transmit the chosen telegram under various Return Loss conditions on Interface 'C1' and Interface 'C6'.

4.2.8.5.5.2 Test Set-up

A proposed partial test set-up is shown on the Figure 35 below including specific details on the Reference Signal Generator (item 13). See sub clause 4.2.8.5.1 on page 98 for additional details on the complete test set-up. Clause F1 of Annex F on page 297 gives an example of suitable test equipment (see also sub clause 4.2.1 on page 23).

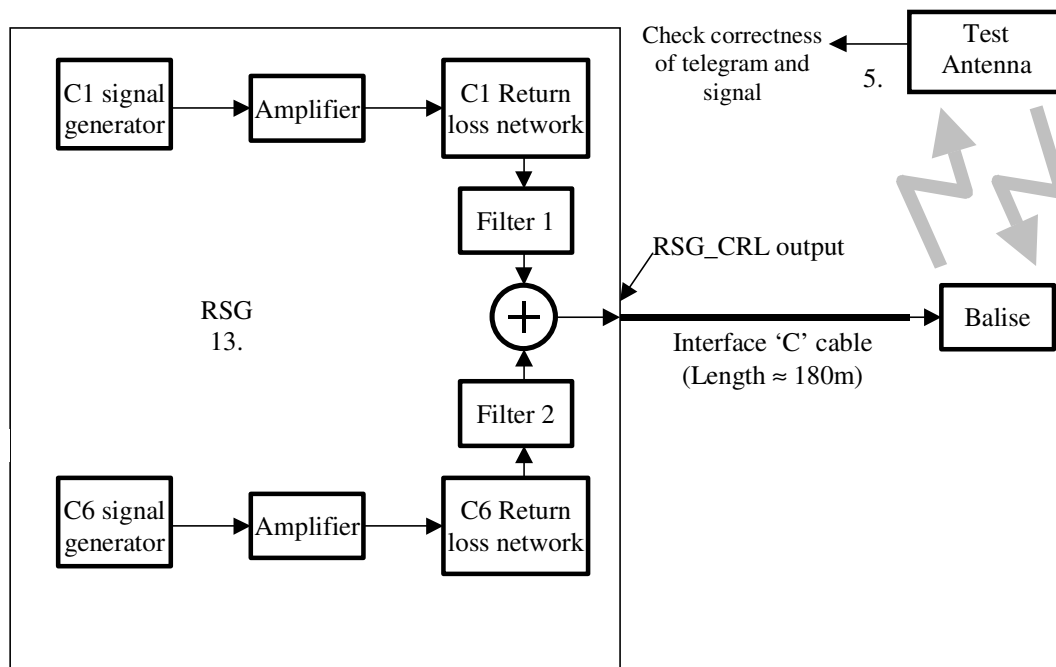

Figure 35: Signal generator (item 13) for Return Loss testing

The C1/C6 Return Loss network shall be capable of providing combinations of several complex Return Loss conditions as indicated in Table 1. A minimum of three different Return Loss conditions shall be tested for Interface 'C1' and for Interface 'C6' (e.g., a low ohm resistive, a capacitive and an inductive condition shall be tested). For Interface 'C1', also a high ohm resistive condition applies.

The test tool shall allow achieving Interface 'C1' Return Losses of 6 dB +0/-0.5 dB within the entire Interface 'C1' signal bandwidth.

The test tool shall allow achieving Interface 'C6' Return Losses of 4 dB +0/-0.2 dB at the Interface 'C6' frequency.

The test object is the Balise with its Interface 'C' cable. The cable type is manufacturer dependent but its length should be around 180 m. The actual length of the Interface 'C' cable shall be such that potential symbol overlap (due to reflections) is simulated in Interface 'C1'.

4.2.8.5.5.3 Test Procedure

1. Position the Test Antenna in position [X = 0, Y = 0, Z = 460].
2. Set the Tele-powering Signal Generator (item 1 in sub-clause 4.2.8.5.1) to the frequency 27.095 MHz, and to CW.
3. Adjust the input current into the Test Antenna in order to achieve approximately $\phi_{d2} +10$ dB through the Balise. This is accomplished when the reading of the Power Meter 1 is equal to P_{27RL} measured as in sub-clause 4.2.8.4.3 on page 97. Calibration data is obtained from sub-clause 4.2.7.5 on page 79.
4. Set the C1/C6 Return Loss network to test case 1 of the matrix (see Table 19).
5. Set the C1 and C6 signal generators (item 13) to the following configuration:

Interface 'C1'	Level (Vpp)	$V_2 = 16 \text{ V} \pm 0.25 \text{ V}$
	Mean Data Rate	564.48 kbits/s \pm 40 ppm
	Telegram	type 1
Interface 'C6'	Level (Vpp)	$22 \text{ V} \pm 0.3 \text{ V}$
	Frequency	$8.820 \text{ kHz} \pm 0.01 \text{ kHz}$

Interface 'C1' and Interface 'C6' signal levels shall be measured at the RSG_CRL output (see Figure 35) into the specified resistive loads (120 Ω and 170 Ω respectively).

6. Check with the reference receiver for Up-link (item 42) that:
 - The Balise transmits the selected telegram.
 - The centre frequency, frequency deviation, mean data rate, and MTIE are within the required range (see Table 9 on page 81).
7. Repeat steps 5 and 6 for each of the four test case of the test matrix.

Test case	'C1' Return loss (within 0.2 MHz to 0.6 MHz) 6 dB +0/- 0.5 dB			'C6' Return loss (within 8.820 kHz \pm 0.1 kHz) 4 dB +0/- 0.2 dB		
	RSG_CRL angle of reflection coefficient ¹⁹ at 423 kHz "Resistive"	RSG_CRL angle of reflection coefficient ¹⁹ at 423 kHz "Capacitive"	RSG_CRL angle of reflection coefficient ¹⁹ at 423 kHz "Inductive"	RSG_CRL angle of reflection coefficient ¹⁹ at 8.82 kHz "Resistive"	RSG_CRL angle of reflection coefficient ¹⁹ at 8.82 kHz "Capacitive"	RSG_CRL angle of reflection coefficient ¹⁹ at 8.82 kHz "Inductive"
1	$180^\circ \pm 10^\circ$			$180^\circ \pm 10^\circ$		
2	$0^\circ \pm 10^\circ$			"Direct connection" with Return Loss > 23 dB and phase angle of $0^\circ \pm 10^\circ$		
3		$-90^\circ \pm 10^\circ$			$-90^\circ \pm 10^\circ$	
4			$90^\circ \pm 10^\circ$			$90^\circ \pm 10^\circ$

Table 19: Test conditions versus Return Loss on Interface 'C1' and 'C6' at LEU output

8. Repeat steps 5 and 6 for test case 1 of the test matrix above when transmitting the Interface 'C1' signal with slopes such that $\tau = 100 \text{ ns} +10/-0 \text{ ns}$.

¹⁹ The reflection coefficient is defined as $r=(Z_n-1)/(Z_n+1)$, where $Z_n=Z/Z_0$, and Z_0 is 120 Ω and 170 Ω for Interface 'C1' and Interface 'C6' respectively.

4.2.8.5.6 Blocking of Up-link Telegram Switching

4.2.8.5.6.1 Test Abstract

At the beginning of a train passage, the Balise shall optionally alter its impedance to signal to the LEU not to change the telegram until after a defined delay. This test verifies this functionality.

4.2.8.5.6.2 Specific Notes

The maximum length of the Interface 'C' cable is 10 m. The influence of the cable from the Balise to the test equipment must be considered and compensated for. This should be automatically performed by the test tool through a calibration procedure using well-known load impedance.

The measurements shall start as soon as the 27 MHz Tele-powering flux has reached the level $\phi_{d1} - 10$ dB on the start up ramp. As far as the calibration of the measurement-triggering instant is concerned, see sub-clause 4.2.7.2.3 on page 73.

4.2.8.5.6.3 Test Procedure

1. Position the Test Antenna in position [X = 0, Y = 0, Z = 460].
2. Set the Signal Generator (item 1) to the frequency 27.095 MHz, and to CW.
3. Adjust the input power to the Test Antenna in order to achieve approximately $\phi_{d2} +10$ dB through the Balise. This is accomplished when the reading of the Power Meter 1 is equal to P_{27RL} measured in sub-clause 4.2.8.4.3 on page 97. Calibration data is obtained from sub-clause 4.2.7.5 on page 79.
4. Set the Tele-powering signal generator (item 1) to simulate a train passage (see sub-clause 4.2.7.2.3 on page 73).
5. Set the Interface ‘C’ signal generator (item 13) to the following configuration:

Interface ‘C1’	Level (Vpp)	$V_2 = 18 \text{ V } +0/-0.25 \text{ V}$
	Mean Data Rate	564.48 kbits/s \pm 40 ppm
	Telegram	all ones, without jitter
Interface ‘C6’	Level (Vpp)	23 V $+0/-0.3 \text{ V}$
	Frequency	8.820 kHz \pm 0.01 kHz

The Interface ‘C’ signal generator shall transmit a continuous stream of ones.

6. Check with the reference receiver for Up-link (item 42) that:
 - The Balise transmits the selected telegram, and that the telegram is not disturbed while the signal is active.
7. Check with the reference receiver for Interface ‘C’ (item 42) that:
 - T_d and T are within the required ranges (see Table 14 on page 95).
 - The input impedance when the signal is active is within the required range (see Table 14 on page 95).

Please note that a trigger is necessary in the test set-up in order to correlate Interface ‘C’ measurements with Interface ‘A’ measurements, and that the Interface ‘C’ signal generator must transmit a continuous stream of ones.

Please note that the blocking signal may be transmitted as soon as the Balise has decided to start-up. This is allowed to happen before ϕ_{d1} . However, there is no requirement that the actual data transmitted earlier than 150 μ s after ϕ_{d1} is correct. Consequently, the evaluation of step 6 is dependent on when the blocking signal is transmitted relative to 150 μ s after ϕ_{d1} .

4.2.8.5.7 Default Telegram Switching

4.2.8.5.7.1 Test Abstract

This test concerns controlled Balises only. It shall verify that the Balise switches over to the Default Telegram under the following failure conditions on Interface 'C':

- A cut cable.
- Absence of signal.

4.2.8.5.7.2 Test Procedure

1. Position the Test Antenna in position [X = 0, Y = 0, Z = 220].
2. Set the Interface 'C' signal generator (item 13) to nominal conditions, and select a telegram of type 1.
3. Set the Signal Generator (item 1) to the frequency 27.095 MHz, and to CW.
4. Adjust the input power to the Test Antenna in order to achieve approximately $\Phi_{d2} + 10$ dB through the Balise. This is accomplished when the reading of the Power Meter 1 is equal to P_{27RL} measured in sub-clause 4.2.8.4.3 on page 97.
5. Check with the reference receiver for Up-link (item 42) that the Balise transmits the selected telegram.
6. Simulate a failure of type 1 with the Interface 'C' signal generator (see sub-clause 4.2.8.5.7.3 on page 109).
7. Check with the reference receiver for Up-link (item 42) that the Balise switched over to the default telegram. Verify that a sequence of between 75 and 128 bits of only logical '1' or only logical '0' is inserted immediately before transmission of the default telegram. The sequence of logical '1' or logical '0' shall be ended no later than a time corresponding to 341 bits after the event that caused the switch to the default telegram.²⁰
8. Remove the failure.
9. Check with the reference receiver for Up-link (item 42) that the Balise continues to send the default telegram during the entire simulated Balise passage.
10. Switch off the Tele-powering for 10 ms.
11. Switch on the Tele-powering. Perform steps 5 through 10 for all the failures listed in sub-clause 4.2.8.5.7.3 on page 109.

²⁰ The point of time for the event that caused the switch is defined such that a stable failure condition is achieved. This means that potential transition regions when changing input signal from fully correct to fully fail shall be excluded from the time corresponding to the 341 bits. Furthermore, the failure condition must be stable for the entire duration of the simulated failure. As for the verification of the length of the sequence of equal bits (75 - 128) preceding the default telegram, consider that the data transmitted by the Balise during the failure condition, up to the transmission of such sequence, can be unpredictable.

4.2.8.5.7.3 Test Matrix

The failure conditions on Interface 'C' are given in Table 20 below.

Failure	Description	Duration
1	Cut cable	0.6 ms -0/+0.4 ms
2	The signal on Interface 'C1' is 0 V, The signal on Interface 'C6' is in nominal conditions	0.6 ms -0/+0.4 ms

Table 20: Failure to be tested for the default telegram switching

Nominal conditions on Interface 'C6' are detailed in sub-clause 4.2.8.3.3 on page 94.

4.2.9 Test for damaging

4.2.9.1 General

This test aims at verifying that the Balise survives exposure of Tele-powering flux levels of up ϕ_{d5} as defined in UNISIG SUBSET-036. This test shall be preceded by the normal I/O characteristic test of sub-clause 4.2.4 on page 47, and be succeeded by a limited test to the extent defined herein.

It shall be verified that the Balise is properly working before the test.

4.2.9.2 Calibration of Tele-powering flux level

The results of the calibration from sub-clause 4.2.5.2 on page 54 shall be used, and shall be extrapolated up to the ϕ_{d5} level.

The target value of the power level from the current sense output of the test antenna may be linearly extrapolated from the Φ_{d4} -6 dB level, but when adjusting this level in the presence of the Balise, a pulsed field should be applied. The length of the pulses should be 10 ms and the duty factor should be 1:100.

4.2.9.3 Test Procedure, Test for damaging

1. Position the Balise with the same geometry of the test set-up used during calibration (with respect to the Reference Mark of the Balise). It is allowed not to connect the Balise controlling interface.
2. Simulate a train passage according to Figure 26 on page 73, with the peak level ϕ_{d5} and the T_{on} duration 10 s (T_{off} is infinite).
3. Perform a limited I/O characteristic test (at ϕ_{d1} , ϕ_{d2} , and ϕ_{d4}) according to sub-clause 4.2.4 on page 47, and verify compliance with the requirements. Testing shall be performed only during free air conditions, and only for the Balise transmitting the Default Telegram (i.e., the Balise controlling interface is not connected).

4.3 Requirements for Test Tools

See Annex B on page 168, Annex D on page 215, and Annex H on page 309.

5 Tests of the On-board Equipment

5.1 Reference Test Configurations

5.1.1 General

The following conditions should apply for the majority of the tests where no specific environmental or operational condition is required.

Ambient temperature	25 °C ± 10 °C
Relative humidity	25 % to 75 %
Atmospheric Pressure	86 kPa to 106 kPa
Debris in the air-gap	None
Antenna Unit speed for dynamic laboratory verifications	0.1 m/s to 0.5 m/s
Antenna Unit speed for dynamic simulated verifications	0 km/h to 500 km/h or highest speed declared by manufacturer
Tele-powering mode	CW
EMC noise within the Up-link frequency band	Negligible

The environmental conditions of the table above should be maintained as far as reasonably possible. Monitoring of the conditions should apply if it can not be guaranteed that the limits are fulfilled.

In order to minimise the possible influence from the surrounding environment, the requirements of sub-clause 4.1.1 on page 21 related to the metal free zone, shall be fulfilled.

5.1.2 Monitored Interfaces

The following test interfaces are foreseen for accessing the test data, for controlling the required operational mode, and for simulating defined test inputs:

- Interface V_1 (see Annex E). It is used for reading the On-board test data reported by the BTM functionality, and for controlling its operational mode. The Interface V_1 can possibly be embedded in the overall Test Interface of the On-board Equipment.
- Interface V_2 (see Annex E) used for periodically sending the current time and odometer data to the BTM functionality in accordance with the train movement (real or simulated) conditions.
- Interface V_4 (see Annex E) used for providing the On-board Equipment, embedding the BTM functionality, with speed sensor signals in accordance with the train movement (real or simulated) conditions.

These test interfaces might require company specific adapters in order to translate format and typology of the information passed through them to the specific needs of the equipment under test.

5.1.3 Test Tools and Procedures

For the purposes of uniform verifications, it is required that:

- When the On-board equipment is set in “test mode”, some test related functions can be driven from the unified Test Interface ‘V₁’, ‘V₂’, or ‘V₄’;
- Some operational and test related data are made available at the test Interface ‘V₁’.

The following list gives a set of anticipated tests:

- Verification of the Tele-powering signal characteristics;
- Verification of the capability of the On-board equipment to handle extreme values of the electrical characteristics of the Up-link signal;
- Characterisation of the static Tele-powering and Up-link radiation patterns of the Antenna Unit;
- Verification of reliable data communication, of correct Balise detection, of correct side lobe management, and of correct location reporting, by simulation of dynamic Up-link Balise signal patterns;
- Verification of the correct handling of different telegram types in steady state as well as in presence of telegram switching, or in presence of telegram errors;
- Verification of the correct handling of different Balise sequence cases, including the simulation of a Balise Group of eight Balises passed at the maximum allowed speed;
- Verification of the correct handling of different telegrams sent by a Balise passed at very low speed;
- Verification of the compatibility with KER Balises;
- Evaluation of physical cross-talk protection margins according to the specified longitudinal and transversal cases;
- Verification of the Antenna Unit supervision function in presence of the defined metal masses;
- Verification of the cross-talk immunity with nearby cables, including the LZB cable;
- Verification of the correct function of the Basic Receiver with respect to various telegram types transmitted one after the other.

The effects of the debris conditions, and of the metallic objects, listed in UNISIG SUBSET-036, should also be individually considered in the transmission tests.

The following tools are anticipated for the Antenna Unit/BTM function tests:

- Test Management System, used for co-ordinating the measurements, controlling the other tools of the test set-up, and for logging and reporting the test results;
- Antenna Positioning Tool;
- Reference Loops (Standard and Reduced Size types) equipped with Baluns;
- Time and Odometer Module for the simulation of the Antenna Unit movement;
- Adapters for Test Interfaces (Company specific);
- Telegram Generator;
- Reference Signal Generators;
- RF instruments and accessories of general use;
- Reference Units for debris, metallic masses, and cables.

5.2 Laboratory Tests

5.2.1 General

5.2.1.1 Introduction

This sub-clause (5.2) defines a test procedure for Antenna Unit and BTM function tests. It also includes the various test set-ups that are required. The test procedure includes the following steps with partially different test set-ups and under different test conditions:

- Characterisation of radiation pattern and creation of signal pattern for dynamic tests.
- Transmission tests.
- Cross-talk tests.
- Up-link characteristics tests.
- Tests of handling various telegrams.
- Tele-powering characteristics tests.
- Balise sequence capability tests.

Each Antenna Unit - BTM function combination shall be tested with all the different Reference Loops.

Reference Loop currents and the flux values shall be in accordance with the input-to output characteristic definition of UNISIG SUBSET-036.

It is essential that the Reference Loops used during the tests fulfil the requirements of clause B2 of Annex B on page 168, and are characterised prior to testing. The procedure for characterisation of the equipment is defined by sub-clause B2.6 of Annex B on page 173.

All distances are in millimetres unless explicitly otherwise stated.

RMS values are applicable unless otherwise stated. Integration time shall be selected in order to achieve sufficient measurement accuracy.

5.2.1.2 General Test Set-up

The recommended general test set-up is shown in Figure 36 below. Clause F1 of Annex F on page 297 gives an example of suitable test equipment.

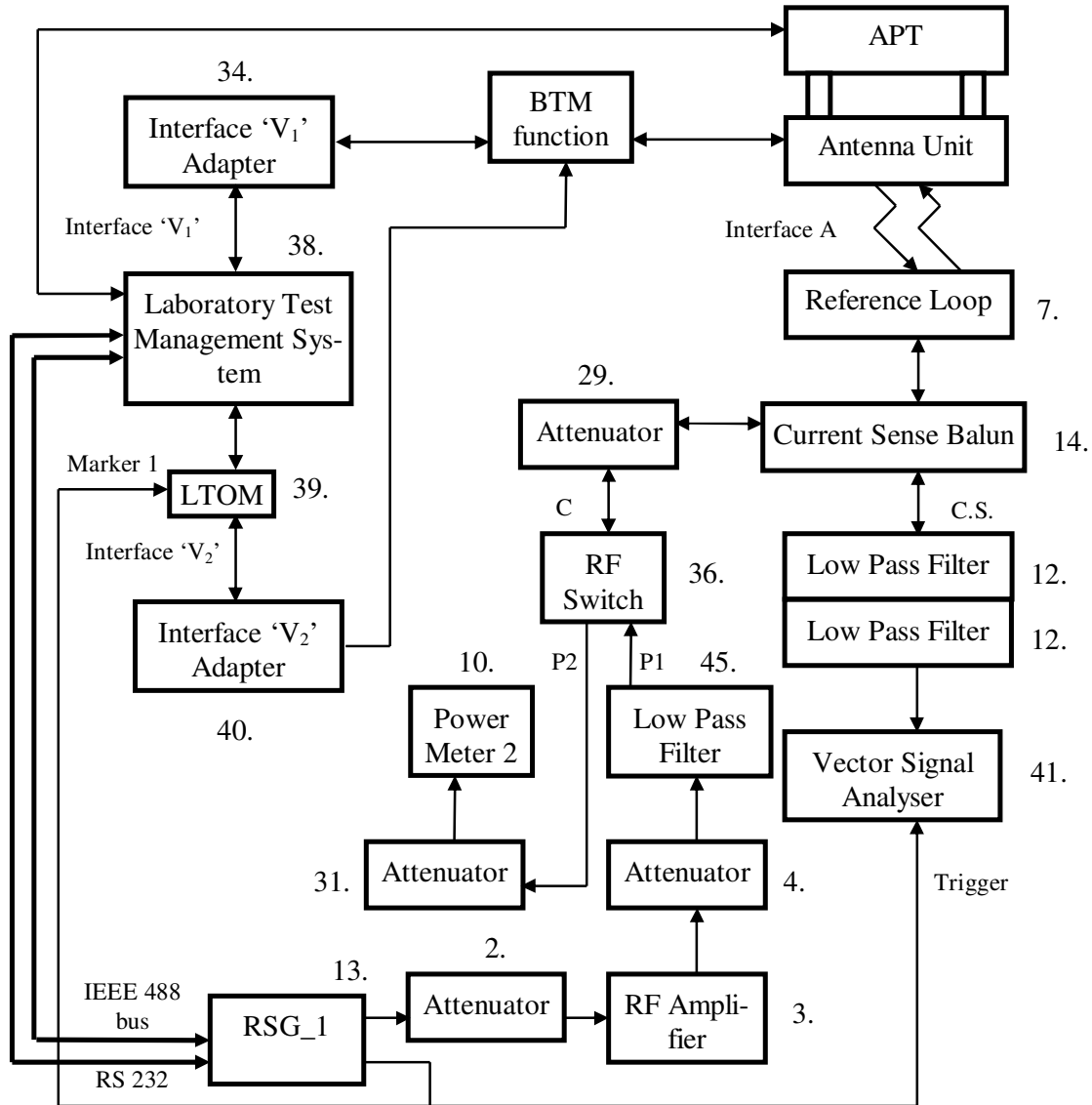

Figure 36: General Test set-up

Items 10 and 36 are computer controlled via the Laboratory Test Management System (the computer control is intentionally not indicated in the figure). Additionally, the Laboratory Test Management System shall provide a trigger signal to item 13 (that starts a pre-defined sequence).

The RS 232 link is a possible solution for transferring data files from the Laboratory Management System to the RSG.

5.2.1.3 Test Set-up Notes

- Note 1: The attenuator (item 29) is used for ensuring a well defined 50 Ω source for driving the Reference Loop.
- Note 2: It is important that all HF transmitter cabling is of low loss double shielded type (e.g., RG214). Furthermore, the cables shall be “de-bugged” using suitable ferrite clamps, evenly spaced along the cables, at distances less than 70 cm.
- Note 3: A Vector Signal Analyser might be needed for verification of correct settings of the Arbitrary Generator.
- Note 4: Please note that attenuation in the RF switches, balun, attenuator, and cabling shall be considered.
- Note 5: The requirement on the RF switch is that the frequency range is DC to several hundred MHz, and that the attenuation is less than approximately 0.2 dB at 30 MHz. At 2 MHz to 30 MHz, isolation and VSWR should be better than 50 dB and 1:1.1 respectively. Switch time should be less than 20 ms. The switch shall be able to withstand a current of at least 2 A.
- Note 6: The two test-set-ups according to Figure 36 on page 114 and Figure 43 on page 135 may be compressed into one uniform set-up provided that a “single pole four throw” RF switch is available (substituting the switches [36] indicated in the figures). This would enable having all the equipment (power meter [10], spectrum analyser [35], oscilloscope [37] and attenuator [31]) permanently connected, and selected by simply controlling the switch.
- Note 7: The attenuator (item 29) may optionally be replaced by one with lower attenuation during Cross-talk tests if this is required in order to achieve sufficient signal levels for obtaining reliable test results. In this case special precautions must be considered in order to characterise the actual Reference Loop load conditions.
- Note 8: It is important to synchronise the observation of the BTM function reporting with the simulation of the Balise passage.
- Note 9: Item 45 (the low pass filter) is used to filter out the 27 MHz power signal sent by the Reference Loop towards the Power Amplifier. The recommended performance of the filter is found in clause F2 of Annex F on page 299. The filter shall be connected directly at the output of the attenuator close to the Reference Loop.
- Note 10: Item 12 (the low pass filters) are used to filter out the 27 MHz signal sent by the Reference Loop towards the Vector Signal Analyser. The specifically recommended performance of the filters is found in clause F3 of Annex F on page 302. The filters shall be located directly at the Current Sense output of the Balun.
- Note 11: The RSG should be programmed in order to issue a trigger pulse in correspondence of the centre of the dynamic up-link signal. This pulse triggers the Vector Analyser to measure the Up-link signal level, and the LTOM to record the corresponding time and odometer data.

5.2.2 Test Conditions

5.2.2.1 Nominal Conditions

5.2.2.1.1 General

The nominal conditions defined in this sub-clause apply to all measurements unless otherwise explicitly stated.

5.2.2.1.2 Climatic Conditions

Ambient temperature: 25 °C ± 10 °C.
Relative humidity: 25 % to 75 %.
Atmospheric Pressure: 86 kPa to 106 kPa.

5.2.2.1.3 Metallic Objects and Debris

No metallic objects shall be present.

No debris shall be applied.

In order not to get any disturbance from the surrounding environment, there shall be a volume around the Antenna Unit and the Balise under test that is free from metallic objects. The minimum extent of this volume is defined in 4.1.1 on page 21. This volume is also referred to as “free space“ condition. The space below 0.4 m (but above 0.7 m) underneath the Balise shall not contain any solid metal planes, and only a few metallic supports are allowed within 0.7 m underneath the Balise.

5.2.2.1.4 Up-link signal Characteristics

The parameters of the 4.23 MHz FSK signal in the air gap shall be set to their nominal values as defined by UNISIG SUBSET-036.

- $f_L = 3.951 \text{ MHz} \pm 20 \text{ kHz}$
- $f_H = 4.516 \text{ MHz} \pm 20 \text{ kHz}$
- Centre Frequency = $4.234 \text{ MHz} \pm 20 \text{ kHz}$
- Frequency Deviation = $282.24 \text{ kHz} \pm 3 \text{ kHz}$
- Mean Data Rate = $564.48 \text{ kbits/s} \pm 100 \text{ ppm}$
- MTIE characteristics in accordance with Figure 37 below.
- In a shift between two frequencies, the carrier shall have a continuous phase
- Amplitude jitter = less than $\pm 1.2 \text{ dB}$

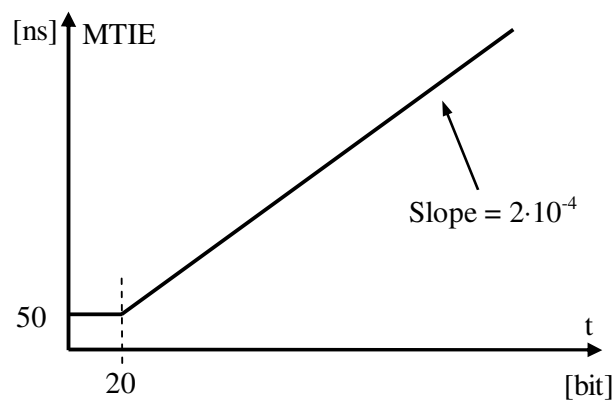

Figure 37: Nominal MTIE requirements

5.2.2.1.5 Tele-powering Characteristics

The 27 MHz Tele-powering signal shall be CW.

5.2.2.1.6 Telegram Contents

In general, the Reference Loop shall transmit a randomised 1023 bit telegram that is valid (fulfilling the coding requirements according to the coding requirements of UNISIG SUBSET-036), and which consists of $50 \% \pm 2 \%$ of logical “one”. The telegram shall comprise an evenly distributed run length, based upon a truncated close to exponential distribution of transitions. This is Telegram Type 8 according to clause A2 of Annex A on page 161.

However, for the purpose of performing tests simulating that a Reduced Size Balise is installed in a line designed for more than 300 km/h, Telegram Type 1 according to clause A2 on page 161 shall be used

5.2.2.1.7 Tilt, Pitch, and Yaw

Tilt, Pitch, and Yaw angles shall be set to 0 (zero).

5.2.2.2 Specific Conditions

5.2.2.2.1 Climatic Conditions

Temperature extremes apply to the antenna under test in accordance with the requirements given in sub-clause 6.6 of UNISIG SUBSET-036.

5.2.2.2.2 Tilt, Pitch, and Yaw

According to UNISIG SUBSET-036, tilting shall be applied to both the Antenna Unit and the Reference Loop.

Therefore, tilt angles shall be set to worst case maximum angle according to Antenna Unit manufacturer specification and the maximum tilting of the Reference Loop of $\pm 2^\circ$. Both the Antenna Unit and the Reference Loop are subject to tilting, and the worst case combination applies.

According to UNISIG SUBSET-036, pitching shall be applied to both the Antenna Unit and the Reference Loop.

Therefore, pitch angles shall be set as defined below. Both the Antenna Unit and the Reference Loop are subject to pitching, and the worst case combination applies.

- Reference Loop pitch angle maximum $\pm 5^\circ$.
- Antenna Unit pitch angle at maximum according to supplier specification.

The influence of yaw angles should not be tested, because no major influence is anticipated.

5.2.2.2.3 Metallic Objects

The test conditions are defined by sub-clause B5.3 of Annex B on page 197. The Antenna Unit shall be subjected to free air conditions during all test conditions except for "Metallic Objects outside the Antenna Unit metal free volume". In the latter case, the Reference Loop shall be subjected to free air conditions.

Please observe that the testing height shall in some cases be limited in accordance with UNISIG SUBSET-036 during testing with metallic plane underneath the Reference Loop, and during testing with steel sleepers underneath the Reference Loop.

The following applies to metallic plane underneath the Reference Loop:

- Standard Size: Maximum test height reduced by $(210 - Z_b)$
- Reduced Size: Maximum test height reduced by $(193 - Z_b)$

The following applies to steel sleepers underneath the Reference Loop:

- Maximum test height reduced by the value d
- Minimum test height reduced by 14 mm for Reduced Size (no reduction for Standard Size)

5.2.2.2.4 Debris

Test conditions, and the design and utilisation of the debris box, are defined by sub-clause B5.2 of Annex B on page 191.

For the Reference Loop, the following conditions apply:

- Salt Water
- Clear Water
- Iron Ore (Magnetite)

The Antenna Unit shall be subjected to free air conditions during these conditions. During these tests, the maximum test height shall be reduced with 20 mm when testing debris Class A applied to the Standard Size Reference Loop. For the Reduced Size Reference Loop the reduction is 43 mm. Testing shall be performed for both debris Class A and Debris Class B. The latter shall be tested without reduction of the maximum height.

For the Antenna Unit, the condition “Ice on the Antenna” applies. The Reference Loop shall be subjected to free air conditions during this test condition. The supplier of the Antenna Unit shall specify the applicable thickness of the ice layer.

5.2.3 Evaluation of Radiation Pattern

5.2.3.1 General Description

The purpose of this test is to find the weakest possible Balise signal and activation flux, during static conditions, where the Antenna Unit - BTM function combination has the ability to detect the Balise and to receive the intended telegram for static geometrical points in the region above the Reference Loop (i.e., exploring the behaviour of the BTM function threshold V_{th} , and the Tele-powering flux). It shall also provide information on side lobe characteristics. The results from this test shall be used as input for creating the signal pattern for a simulated dynamic Balise passage as defined in sub-clause 5.2.4 on page 124, and used during the applicable tests of this document.

The procedure includes two steps. One is to measure the actual Tele-powering flux through the Reference Loop. The other is to determine the required Up-link current through the Reference Loop corresponding to the BTM function threshold (V_{th}). This corresponding current is denominated I_{th} . Tele-powering and Up-link characterisation are performed in two different passes unless it can be shown that concurrent evaluation (keeping Tele-powering signal on while simultaneously measuring Up-link performance) gives the same results (considering the measurement accuracy as defined in sub-clause 3.3 on page 20).

During Tele-powering measurements, the actual flux ϕ through the Reference Loop is measured. Spot check testing with toggling Tele-powering signal shall be performed in case this is supported by the equipment under test. In case that differences are identified compared to when the CW signal was applied, then this shall be considered when calculating the signal pattern described in sub-clause 5.2.4 on page 124.

During Up-link testing, the Reference Loop shall be connected to a signal generator generating an FSK Up-link signal that simulates a representative Balise passage (see Figure 38 below), and carrying a correct telegram with a peak current level stepwise varied in order to reach I_{th} (as described below). The BTM function output response shall be observed via Interface 'V₁'. The BTM function is set in normal operational mode.

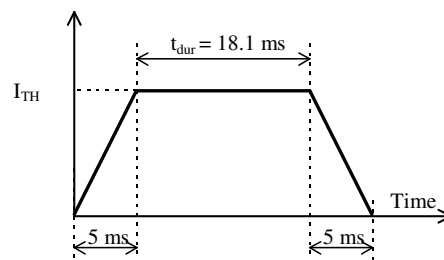

Figure 38: Up-link signal

The time t_{dur} shall be selected so that ten complete 1023 bit telegrams are transmitted. The odometer input signal shall be selected so that the flat part of the sequence according to Figure 38 above corresponds to approximately 0.5 m at a speed of 100 km/h (the entire sequence from start of rising edge to end of falling edge corresponds to approximately 0.78 m).

During Up-link testing, a start value of I_{u1} through the Reference Loop shall be selected. Thereafter, the current level is either increased or decreased in steps until the BTM function threshold is reached. For increased current levels, steps of 0.2 dB are applicable up to $I_{u1} + 7$ dB, thereafter steps of 0.5 dB apply up to a maximum current level of $I_{u1} + 24$ dB. For decreasing current levels, steps of 0.5 dB apply down to the level I_{th} . Please observe that potential hysteresis phenomena shall be evaluated and considered. In case of hysteresis, I_{th} shall always be determined for increasing current levels.

Actual Tele powering flux ϕ , and the threshold current I_{th} are recorded for each single geometrical test point defined in clause C4 of Annex C on page 208. This procedure shall be repeated for all the test conditions defined in sub-clause 5.2.2 on page 116 and limited by the test matrices of clauses C6 and C7 in Annex C on pages 210 and 212 respectively. It is important that the position [$X = 0$, $Y = 0$, $Z = \text{maximum height}$] is explored, because this forms the reference for the calculations of sub-clause 5.2.4 on page 124. The threshold current for this position will be denominated I_{THREF} .

Telegram Type 8 as defined by clause A2 of Annex A on page 161 shall be used during this process.

5.2.3.2 Test Procedure, Evaluation of Radiation Pattern

Test set-up in accordance with sub-clause 5.2.1.2 on page 114 applies.

1. Position the Antenna Unit in the geometrical test point [$X = 0$, $Y = 0$, $Z = \text{maximum height}$], and select nominal test conditions defined by sub-clause 5.2.2.1 on page 116.
2. Set the RF switch in position P2.
3. Command the BTM function to its normal operational mode regarding CW Tele-powering, or to any other mode equivalent to this (from the point of view of the Up-link diagram evaluation).
4. Record the value of power meter 2.
5. Temporarily command the BTM function to transmit toggling Tele-powering signal in case this is supported by the equipment under test, and record the value of power meter 2. Potential change of worst case conditions shall be considered in calculations of sub-clause 5.2.4 on page 124.
6. Command the BTM function back to nominal conditions (CW signal).
7. Repeat step 4 for all remaining geometrical test points defined by clause C4 on page 208 and clause C6 on page 210.
8. Calculate and record the flux through the Reference Loop using the following equation:

$$\Phi = \frac{\sqrt{50 \cdot P_{PM2}} \cdot B \cdot \left(\frac{|50 + Z_{loop}|}{50} \right)}{2 \cdot \pi \cdot f_{27}}$$

where: P_{PM2} is power recorded by power meter 2
 B is the Reference Loop transfer matching ratio
 Z_{loop} is the actual impedance of the Reference Loop in the absence of any antenna
 f_{27} is the Tele-powering frequency (27.095 MHz)

Please observe that the attenuation and impedance of the RF switch, the attenuator, and the current sense Balun have to be considered (characterised prior to testing). This is not considered in the equation above.

9. Set the RF switch in position P1.
10. Set the arbitrary generator to generate an Up-link signal in accordance with Figure 38 on page 120. The initial current setting shall be the minimum controllable current (in the order of 1 mA). The current is measured by the Vector Signal Analyser, and the related transfer response of the Current Sense Balun is in accordance with sub-clause H5.4 on page 329. Please observe that the current measured by the Vector Signal Analyser needs to be compensated for the B-factor of the Reference Loop (i.e., the measured target current shall be the desired Reference Loop current divided by B). Set the time and odometer information to comply with a speed of 100 km/h.
11. Position the Antenna Unit in the geometrical test point [$X = 0$, $Y = 0$, $Z = \text{maximum height}$].
12. Record the output from the BTM function (via Interface 'V1'), and determine whether the Up-link signal was above or below the BTM function threshold (V_{th}). That is correct Balise localisation and reception of the intended telegram, out of those sent in the Up-link signal pattern, is reported.
13. In case that the signal was above the threshold, gradually decrease the current level in steps as defined by sub-clause 5.2.3.1 on page 120 until the signal drops below the threshold. In case that the signal was below the threshold, gradually increase the current level in steps as defined by sub-clause 5.2.3.1 on page 120 until the signal exceeds the threshold. Record the actual threshold value I_{th} . Please observe the note regarding hysteresis in sub-clause 5.2.3.1 (this may always require determination of I_{th} for increasing current levels).

14. Repeat steps 12 and 13 for all remaining geometrical test points defined by clause C4 on page 208 and clause C6 on page 210. In order to speed up the procedure, the iterative evaluation of the new threshold value I_{th} can be done starting from an optimised value based on the values evaluated for the previous nearby positions.
15. Repeat steps 1 through 14 for all specific test conditions defined by sub-clause 5.2.2.2 on page 118 and clause C6 on page 210. Please observe that “nominal conditions” of step 1 is substituted by the relevant “specific condition” for each subsequent pass.
16. Repeat steps 1 through 5 and 9 through 13 at the temperature extremes, and evaluate possible change of performance. Potential change of performance shall be considered in calculations of sub-clause 5.2.4 on page 124.

It must be verified that reliable Up-link measurements can be performed in the presence of the applicable 27 MHz Tele-powering signal.

5.2.4 Creation of Signal Pattern for Dynamic Tests

5.2.4.1 General Description

The aim is to create a time varying 4.2 MHz current through the Reference Loop that simulates a Balise passage without any physical movements of the equipment. In other words, it is a time dependent modulation of the Up-link signal (in addition to the normal modulation forming the FSK signal). During the following applicable tests of this document, the Reference Loop will be positioned in [X = 0, Y = 0, Z = maximum height]. This is the geometrical reference point.

The recorded Tele-powering flux level (ϕ in Figure 39 on page 126) shall be used for determining the response from two different worst case Balises (I_{LOW} and I_{HIGH} in Figure 39 on page 126), utilising the lower and upper limits of the transfer response curve defined by UNISIG SUBSET-036.

Thereafter, considering data (I_{th}) obtained during the radiation pattern tests defined by sub-clause 5.2.3 on page 120, a signal pattern simulating a Balise passage shall be calculated. For all geometrical positions (and all applicable Test Conditions) the actual current required for passing the BTM function threshold (I_{th}) shall be compared with I_{THREF} (see below). A special geometrical test point is [X = 0, Y = 0, Z = maximum height] that serves as reference. The corresponding threshold value is denominated I_{THREF} .

The ϕ and I_{th} patterns recorded along the X-axis for each lateral and vertical displacement, and for each Balise type (illustrated in Figure 39 on page 126), will have to be stored in separate files in order to use them for simulating dynamic signals of Balise passages.

The signal pattern to be calculated (and simulated) is the Up-link signal current through the Reference Loop, constituting the sum of the weakest or strongest possible Balise and the difference between I_{th} and I_{THREF} (considering the correct sign). Furthermore, realistic start-up behaviour of the Balise shall be simulated (including a certain delay time T_{bal}) for the weakest possible Balise. The latter includes that the Balise is inactive until a flux level of ϕ_{d1} is reached, and that a delay time T_{bal} of 150 μ s is applicable. Each simulated Balise passage shall be normalised with respect to I_{THREF} .

In order to visualise that data has to be collected once only, followed by proper scaling to simulate a desired velocity, the example of signal pattern generation is split up in two parts (see Figure 39 on page 126 and Figure 40 on page 127). The first part, required to be performed once only, deals with position related events (see Figure 39). The second part, to be repeated for each single velocity to be simulated, deals with time related events (see Figure 40). The following examples of algorithms for signal pattern generation (see sub-clause 5.2.4.3 on page 128) deals with the position related part only.

Figure 39 on page 126 and Figure 40 on page 127 visualise the process described above. The upper diagram in Figure 39 is an example of flux level (ϕ) through the Reference Loop for various geometrical positions (as determined from sub-clause 5.2.3 on page 120). The lower curve of the middle diagram (I_{LOW}) is the 4.2 MHz current through a weakest possible Balise considering the lower limits of the transfer response characteristics of UNISIG SUBSET-036. A similar curve is shown with dotted lines for the strongest possible Balise (I_{HIGH}). The upper curve of the middle diagram (I_{TH}) is the actual 4.2 MHz current through the Reference Loop that results in an Up-link signal reaching the BTM function threshold (result from sub-clause 5.2.3 on page 120). The lower diagram of Figure 39 constitutes the calculated current ($I_{(x)}$) versus position that is to be driven through a Reference Loop positioned directly underneath the Antenna Unit in position [X = 0, Y = 0, Z = maximum height] in order to simulate a Balise passage. Finally, Figure 40 illustrates how to consider time-related events, thus calculating the current through the Reference Loop as a function of time (I_{CALC}). The time scale is dependent on the velocity to be simulated. The Balise start up behaviour mentioned above is also indicated.

Please note that the normalisation with respect to I_{THREF} has to be performed. This is performed by calculating the difference in threshold value between the geometrical reference point (I_{THREF}) and the threshold value for each position.

Please note that I_{THREF} is one single value taken at the reference position during free air conditions without any tilting (i.e., nominal conditions).

Please also note that potential changes of worst case conditions due to changed performance at the temperature extremes, and due to potential changes during toggling Tele-powering signal, shall be considered.

The Tele-powering radiation diagrams evaluated for all the tested conditions (in CW) shall be lowered by the same amount (in dB) found in toggling mode in case this is supported by the equipment under test, when considering the weakest Balise. The temperature effect (increase or decrease effects) should cause (when it causes a flux reduction) a lowering of the lowest Tele-powering radiation diagram in nominal conditions, for the case of the weakest Balise. On the contrary, a flux increase should apply to the highest Tele-powering radiation diagram in nominal conditions, for the strongest Balise. Similarly for the temperature effect on the up-link diagrams, an increase of the reference current due to temperature should raise by the same amount the highest Up-link diagram applicable to the weakest Balise, and a decrease should result in a lowering of the same amount of the lowest Up-link diagrams applicable to the strongest Balise.

The time scale shall be determined using the following equation:

$$t = \frac{x}{v}$$

where v is the velocity to be simulated (supplier dependent).

The following cases shall as a minimum apply:

- Each 50 km/h from 20 km/h up to and including the maximum speed for the break points in the lateral deviation versus speed diagrams defined by the supplier, and 300 km/h. This shall be performed for all the Antenna Unit heights defined by clause C4 on page 208.
- Low speed conditions (approximately 10 km/h) at minimum height and no lateral deviation.

$I_{(x)}$ of Figure 39 shall be calculated using the algorithm exemplified in sub-clause 5.2.4.3 on page 128.

5.2.4.2 Example of Signal Pattern Generation

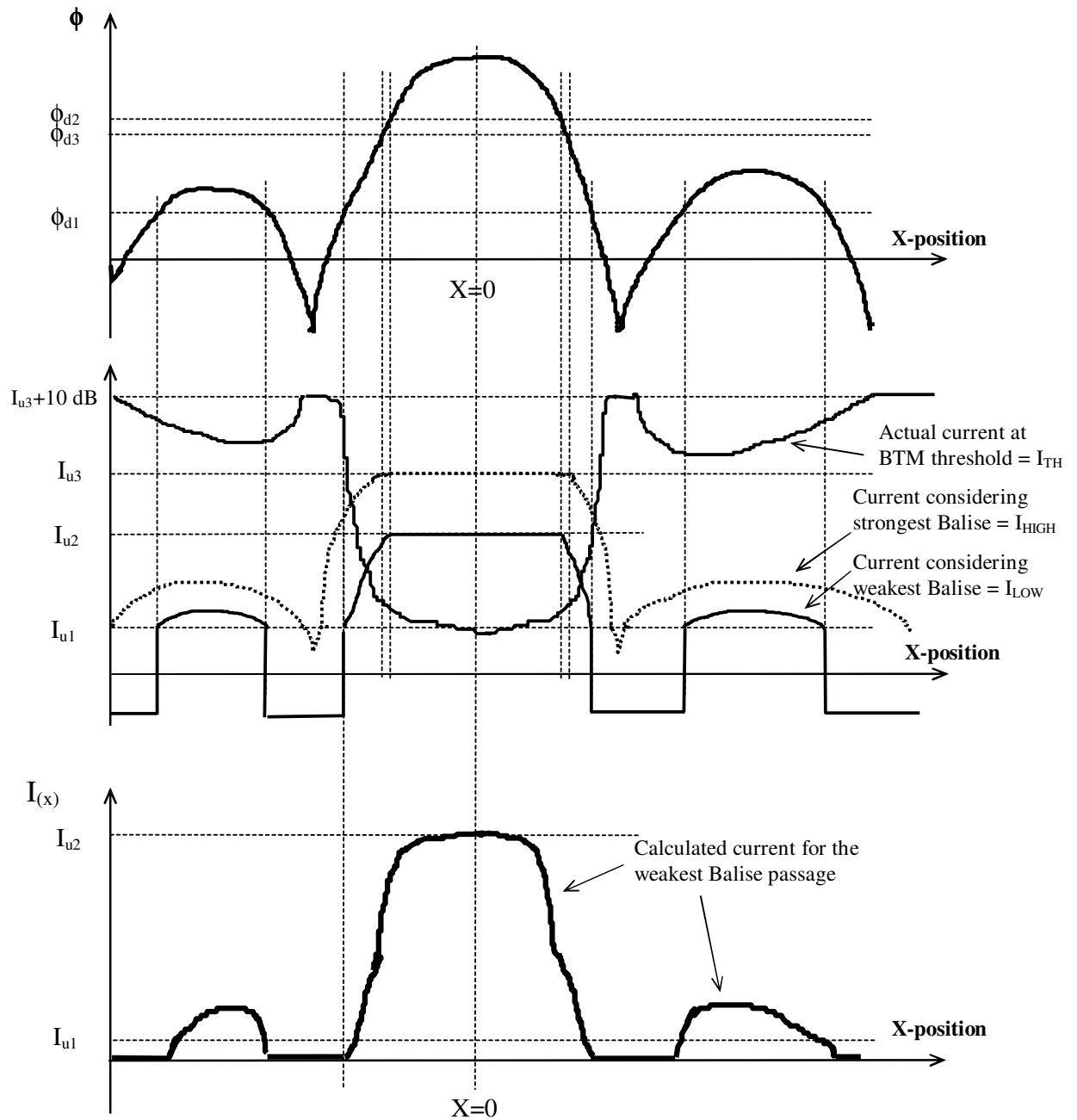

Figure 39: Example of Signal Pattern Generation (position related events)

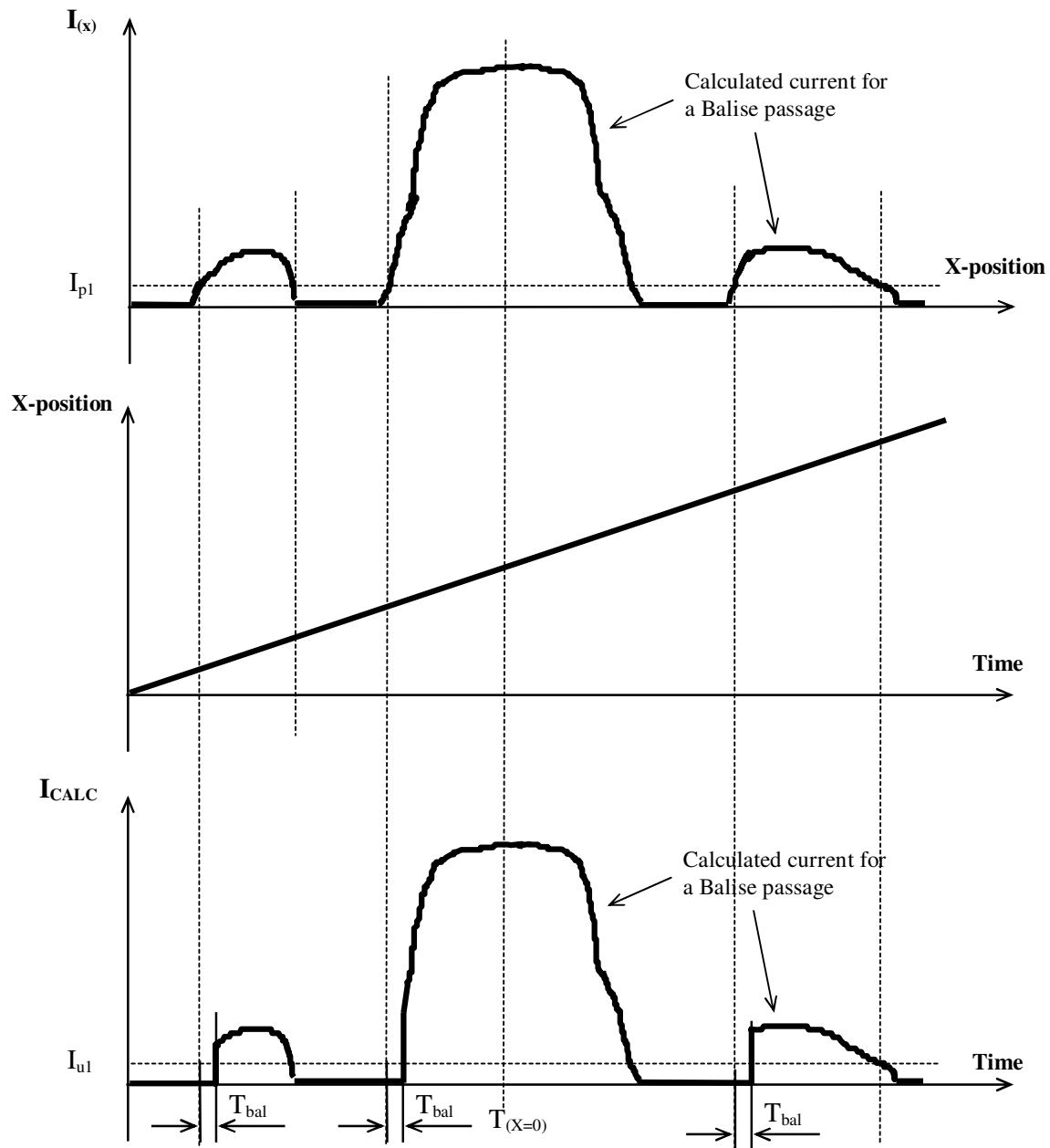

Figure 40: Example of Signal Pattern Generation (time related events)

I_{p1} is the current level corresponding to the point of time when the flux level exceeds Φ_{d1} . In general, the delay T_{bal} is applicable after the point of time when the flux exceeds Φ_{d1} . However, this only has potential impact on the ability to detect (weakest possible) Balises, since it shortens the contact length. When dealing with the strongest possible Balise, the focus is on cross-talk (where Balise Detection aspects are irrelevant from a contact length point of view). Hence, it is adequate to ignore aspects related to T_{bal} for the strongest possible Balise. Consequently T_{bal} should be ignored when generating signal patterns for the strongest possible Balise.

5.2.4.3 Example of Algorithm for Signal Pattern Generation

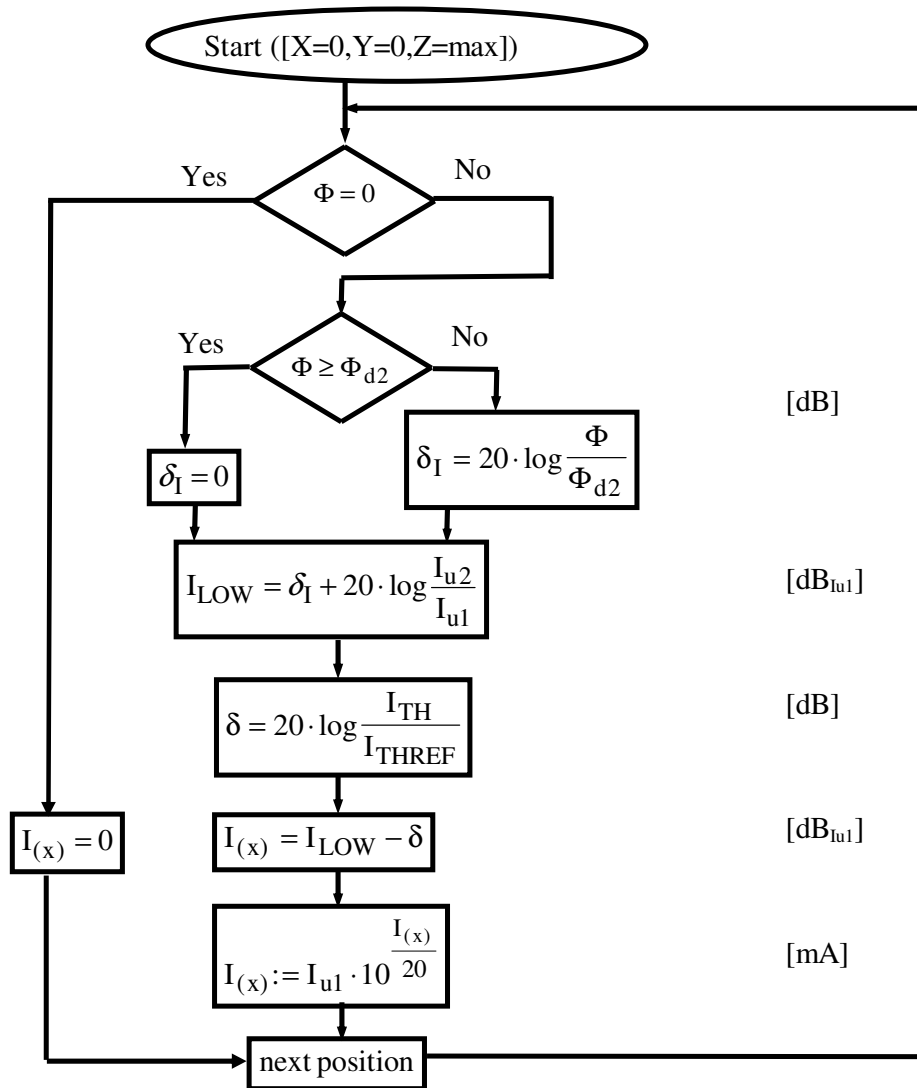

Figure 41: Algorithm for Signal Pattern Generation, weakest Balise

Please note that it is the principle that is shown in Figure 41 only, and that the algorithm deals with the position related events illustrated in Figure 39 only. Also margins for variations over temperature, and for toggling Tele-powering signal in case this is supported by the equipment under test, must be considered (see sub-clause 5.2.4.1 on page 124). Units are indicated to the right of the figure.

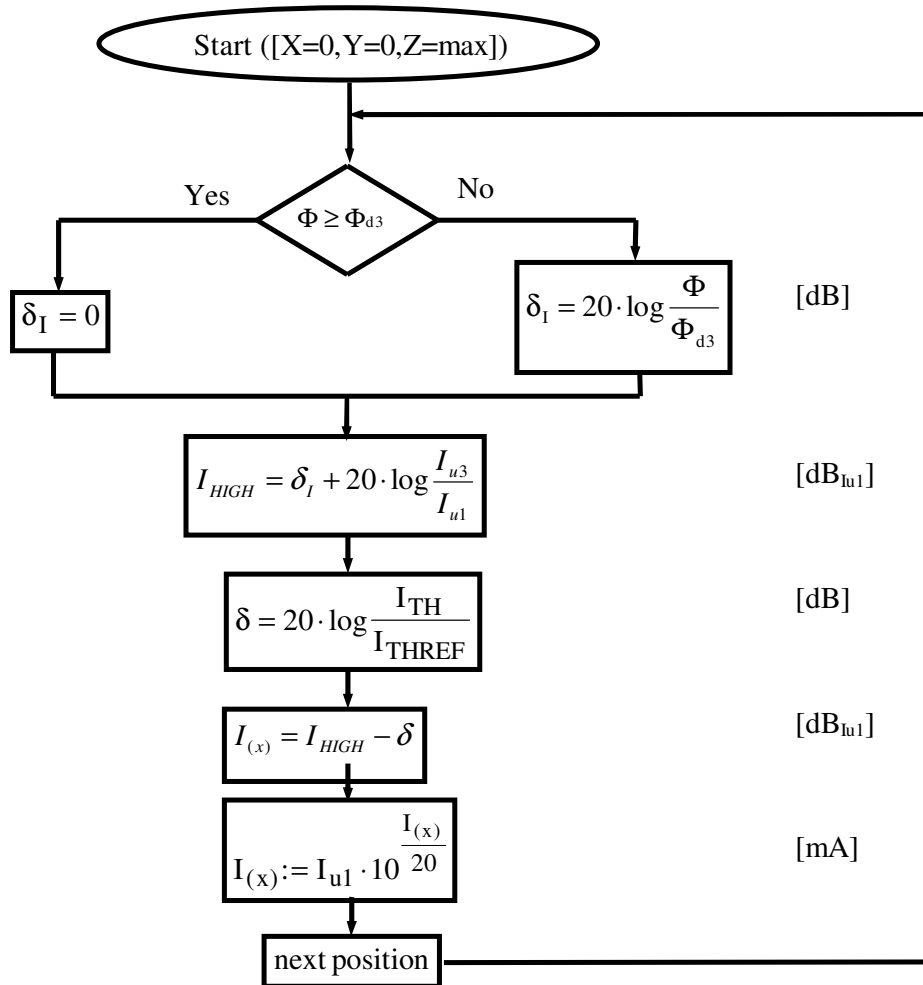

Figure 42: Algorithm for Signal Pattern Generation, strongest Balise

Please note that it is the principle that is shown in Figure 42 only, and that the algorithm deals with the position related events illustrated in Figure 39 only. Additional margins for variations over temperature, and for toggling Tele-powering signal in case this is supported by the equipment under test, must be considered (see sub-clause 5.2.4.1 on page 124). Units are indicated to the right of the figure.

5.2.5 Transmission Tests

5.2.5.1 General Description

The purpose of this test is to determine the capability of the Antenna Unit - BTM function combination with respect to Balise Detection, reliable data transmission, side lobe management, and location accuracy during simulated dynamic conditions. It also serves as a test of system dynamics (strongest and weakest possible signals will occur during the test).

Balise Detect is defined as when the field strength from the Balise is higher than V_{th} during a minimum time T_{DET} . T_{DET} may vary with speed. Reliable data transmission means that an extra time T_{REL} (resulting in multiple good telegrams) has been considered in order to ensure reliable transmission (all in accordance with UNISIG SUBSET-036).

The input signal to the Reference Loop generating the Up-link signal shall be in accordance with results from sub-clause 5.2.4 on page 124. The time scale shall be selected in order to comply with speeds at each 50 km/h from 20 km/h up to the maximum specified velocity for the lateral deviation (Y position) to be simulated. The odometer input signal shall be selected accordingly.

For each simulated case (simulating various lateral deviations and vertical heights), the BTM function output signal shall be observed via Interface V_1 and evaluated. The BTM function shall be set in the normal operational mode.

The criteria for the Antenna Unit - BTM function being able to correctly handle a certain sequence is that the BTM function reports the correct telegram, the correct Balise location for the sequence in question, an adequate reliable data transmission time, and that the BTM function reporting time requirements are fulfilled.

In order to evaluate the correctness of the reported Balise location, the Balise simulations should be precisely allocated (exact distance from a chosen reference point) in a “virtual test line” used for each test sequence. The evolution of each sequence will be controlled by the Laboratory Test Management System (the LTMS). The LTMS will off-line scale each position based Balise pattern into a sequence of time based patterns according to the desired Balise “positions” and to the chosen train speed (see Figure 40 on page 127). Then the LTMS down-loads all the relevant data to the arbitrary generator, and finally looks at the real-time odometer data coming from the LTOM. It issues a triggering pulse for the arbitrary generator when the odometer information of each Balise starting is reached. The Balise centre positions reported by the BTM function will be checked against the reference position of the simulated sequence.

All Test Conditions according to sub-clause 5.2.2 on page 116 shall be considered. Certain tailoring is defined by clause C6 of Annex C on page 210.

The present tests are performed with the antenna located in the reference position and in nominal environmental conditions. The applicable specific test conditions are simulated by using the radiation diagrams corresponding to such real conditions.

5.2.5.2 Test Procedure, Transmission Tests

Test set-up in accordance with sub-clause 5.2.1.2 on page 114 applies. Steps 1 through 5 below constitute calibration of the level of the generated Up-link signal for the test case in consideration. Succeeding steps form the actual test procedure.

1. For each individual test case (of those listed in clauses C4, C6 and sub-clause 5.2.2.2), calculate the position related pattern exemplified in Figure 39 on page 126 (thus obtaining $I_{(x)}$) using the radiation pattern data obtained in sub-clause 5.2.3.2, properly scaled to the reference position used for the Antenna Unit under test. Thereafter, calculate the time related pattern for weakest Balise passage, using the equation of sub-clause 5.2.4.1 on page 124, and exemplified in Figure 40 on page 127 (thus obtaining I_{CALC}). For the purpose of the latter calculation, a speed of 26 km/h shall be applied.
2. Position the Antenna Unit at a position corresponding to $X = 0$, $Y = 0$, and at maximum height defined by the Antenna Unit supplier (i.e., the same reference position used for the evaluation of the radiation diagrams). Set the BTM function in “normal CW operational mode”, and use nominal test conditions (see sub-clause 5.2.2.1 on page 116).
3. Set the RF switch in position P1.
4. Set the time and odometer input data (provided by the LTOM) to comply with the required speed of 26 km/h. Please note that there might be system-related properties setting certain limitations on properties such as acceleration etceteras.
5. Set the arbitrary generator to generate a nominal FSK Up-link signal and apply the time related pattern obtained from step 1 above. Adjust the output level from the RSG_1 (by means of subsequent Balise passage simulations) such that the correct level (within ± 0.3 dB) is obtained at the below defined two points. The window used for the level measurements by the Vector Signal Analyser shall be such that a duration of $2.4 \text{ ms} \pm 0.25 \text{ ms}$ is used, and that this duration does not exceed a corresponding geometrical distance of 20 mm. The current is measured by the Vector Signal Analyser, and the related transfer response of the Current Sense Balun is in accordance with H5.4 on page 329. Please observe that the current measured by the Vector Signal Analyser needs to be compensated for the B-factor of the Reference Loop (i.e. the measured target current shall be the desired Reference Loop current divided by B). The level of the up-link pattern shall be checked in the following points:
 - The position in time where the peak current in the calculated pattern occurs.
 - The position in time closest to where the current exceeds the receiver threshold (measured at the reference position of the Antenna Unit) by 1 dB (but never lower than 0.5 dB above the threshold). The first position in time after the centre of the main lobe should be selected for this purpose.

In case there are problems fulfilling the target for both positions, the position close to the threshold has priority. In case not fulfilling both targets, this observation shall be recorded in the test record, and it shall be made clear that this is a test set-up imperfection.^{21 22}

6. Re-calculate the time based pattern to be used for testing according to the equation of sub-clause 5.2.4.1 on page 124, according to the example in Figure 40 on page 127 (I_{CALC}), and using one applicable velocity defined by sub-clause 5.2.4.1 on page 124.

²¹ It is also important to verify, off-line, that the Tele-powering signal does not influence the actual Up-link signal driven through the Reference Loop.

²² This check needs to be performed for the reference position only. The purpose is to identify potential test set-up imperfections.

7. Set the time and odometer input data (provided by the LTOM) to comply with the desired speed (to be defined by the manufacturer of the BTM function and defined by sub-clause 5.2.4.1 on page 124). Please note that there might be system related properties setting certain limitations on properties such as acceleration etceteras.
8. Perform a sequence of at least 10 subsequent sweeps with the data determined above and record the output from the BTM function (via Interface 'V₁'), together with the reference location data provided by the LTOM. Measure, by the Vector Signal Analyser, and record also the value of the up-link current peak at each Balise passage simulation, evidencing the occurrence of cases of peak values slightly out of tolerance, possibly due to drifts of the RSG₁.²³
9. Repeat steps 6 through 8 for all remaining applicable velocities defined by sub-clause 5.2.4.1 on page 124.
10. Repeat steps 1 through 9 or 6 through 9 (as appropriate) for all remaining combinations of longitudinal ranges, lateral displacements and heights (as defined by the Antenna Unit supplier) using the cases defined in clause C4, on page 208 and clause C6 on page 210. Please note that the physical location of the Antenna Unit and the Reference Loop shall not be changed.
11. Repeat steps 1 through 9 or 6 through 9 (as appropriate) for all remaining specific test conditions defined by sub-clause 5.2.2.2 on page 118 and clause C6 on page 210. Please note that the physical location of the Antenna Unit and the Reference Loop shall not be changed, and that no debris or metallic objects shall be present (the influence of such conditions is included in the data from the radiation pattern this is the basis for the calculation of the signal pattern).

The Operator has the possibility to set the LTMS with the input parameter "Interface V₁ Delay Time" that accounts for the overall transit time of the BTM function report (regarding the "BALPASS variable") through the Interface 'V₁'. This includes from the instant in which the BTM function makes it available to the Interface Adapter up to the instant in which the variable is available to the LTMS upper level processing. This time (probably of the order of 1 s to 2 s) does not need to be very precise because of its use explained here below.

The LTMS performs the following steps in relation to the simulation of a certain Balise passage:

- a) It clears the reports table of the Interface V₁ and the marker table of the LTOM (possibly present from the previous simulation) and then sends a trigger command to the RSG.
- b) It waits for the RSG answer. After receiving it, it waits for a time window given by the sum of the following terms:
RSG_delay + Interface_V1_delay + 1.3 m/speed + 100 ms. Please consider that the time accuracy of the LTMS cannot be better than 100 ms to 200 ms.
- c) When this time-out expires, it checks the validity of all the reports received at the Interface 'V₁' using the marker data provided by the LTOM for the Balise centre as a reference. Please consider that the LTOM data are very precise even at 500 km/h. The check of the BTM reports includes presence of at least one report, correct user bits, sufficient number of valid telegrams, validity of the "BTM Reporting Time" and accuracy of the location data (expressed as time and/or distance). In case of multiple reports, the LTMS accumulates the number of telegrams indicated in each report and uses this number for evaluation. It also checks the validity of the user bits in each report indicating a non-zero number of telegrams. The "BTM Reporting Time" is checked for all the reports present in the Interface 'V₁' Table. The lower limit for the "BTM Reporting Time" is LTOM_centre_time - 1.3 m/speed, and the upper limit is LTOM_centre_time + 1.3 m/speed + 100 ms.
- d) Then it waits for a time corresponding to the location of the next Balise simulation (at the simulated train speed).
- e) When the time arrives for the new Balise simulation, firstly it checks that no new report has been added to the list examined in point 3 above. If this happen there is an error indication otherwise a new cycle is started from step 1 above.

²³ The measurement is performed within a time window corresponding to about 20 mm at the current test speed.

5.2.5.3 Acceptance Criteria, Transmission Tests

The criterion is that the BTM function is able to correctly receive a Balise during the simulated sequence. This means that the following properties are correctly reported:

- Telegram.
- Location.
- Overall number of non-overlapping good telegrams defined by the manufacturer considering the safety targets within the class of reception defined.
- BTM function reporting time (time for data being available to the ERTMS/ETC Kernel).
- Class of reception.
 - * Class A without any error correction.
 - * Class B_n with error correction (where n is any number defined by the supplier).

It shall be checked that there is a logical consistency between the various fields of the data transmitted by the BTM function. Missing or erroneous reporting means that the Balise could not be received. For low speed conditions, the BTM function could perform reporting each 100 ms. In such case, the last report corresponding to a given Balise passage simulation should be considered for the verifications defined above. See also bullet 'c' of sub-clause 5.2.5.2 on page 131.

A BTM function report that is unduly given outside a Balise passage simulation (considering all relevant delays) shall be regarded as a failure condition.

5.2.6 Electrical Tele-powering Characteristics

5.2.6.1 General Description

The purpose of this test is to systematically evaluate the performance of the Tele-powering signal generated by the Antenna Unit - BTM function combination. The electrical characteristics of the signal (such as carrier frequency and carrier noise) and modulation characteristics (in Interoperability mode if supported by the equipment under test) are subject to testing.

The output signal shall be evaluated during static conditions in CW mode and Interoperability mode (if supported) respectively. The output signal shall be measured using a Reference Loop.

The BTM function shall be forced to applicable modes using suitable commands inserted via Interface V₁.

Geometrical test points and applicable test conditions are defined by sub-clauses C7.1 on page 212 and C7.2 on page 213.

5.2.6.2 Test Set-up for Tele-powering verification

The recommended test set-up is shown in Figure 43 below. Clause F1 of Annex F on page 297 gives an example of suitable test equipment.

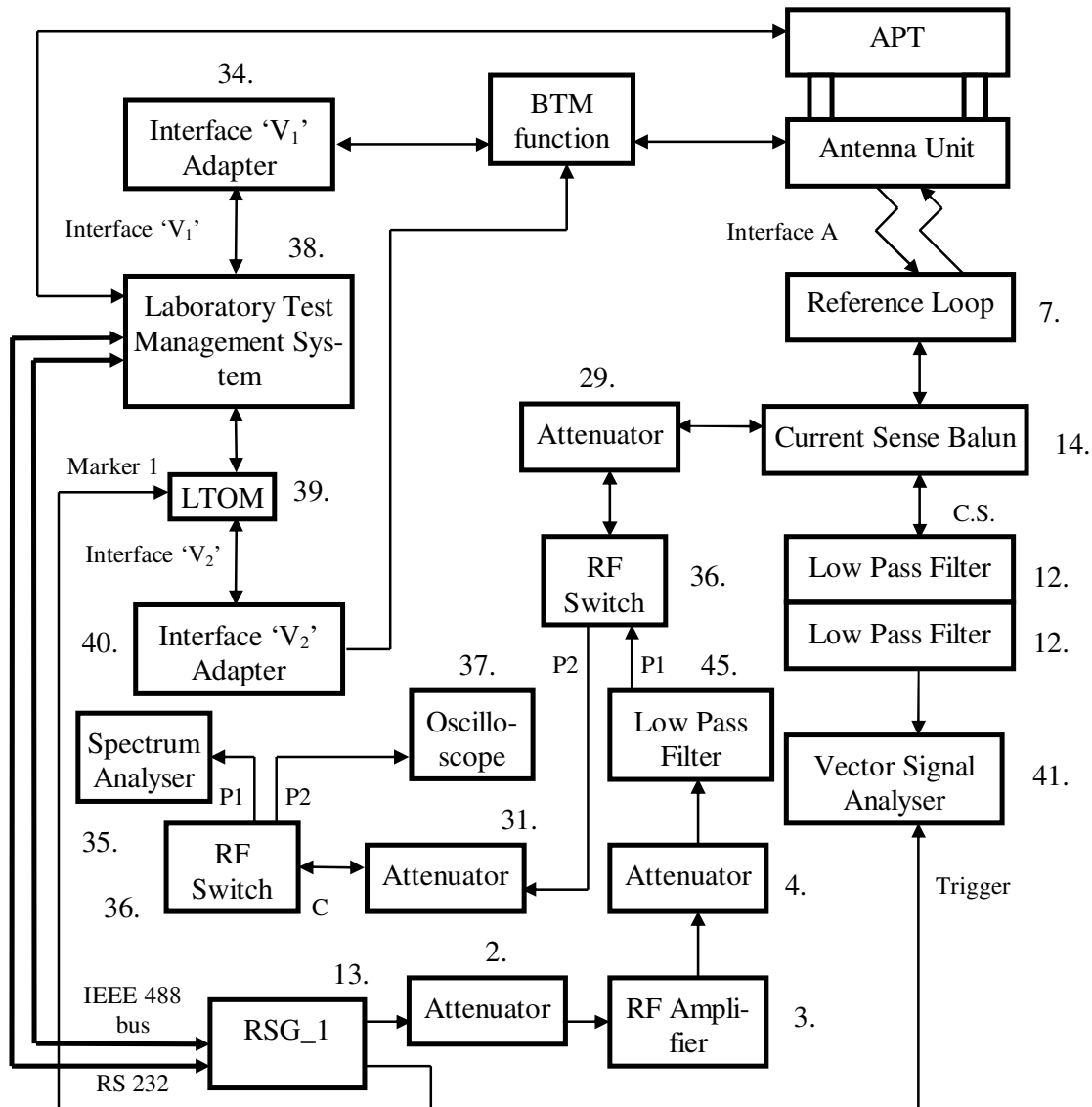

Figure 43: Test set-up for Tele-powering verification

Items 35, 36, and 37 are computer controlled via the Laboratory Test Management System (the computer control is intentionally not indicated in the figure).

5.2.6.3 Test Procedure, CW Mode

Test set-up in accordance with sub-clause 5.2.6.2 on page 135 applies.

The spectrum Analyser setting should be the following:

- Centre Frequency = 27.095 MHz
- Frequency Sweep = ± 100 kHz
- Resolution Band Width = 100 Hz
- Video Band Width = 100 Hz

The noise measured by the spectrum analyser with 100 Hz resolution band width shall be 90 dB below the carrier. The evaluation of carrier noise shall be performed within the frequency ranges f_c-100 kHz to f_c-10 kHz and f_c+10 kHz to f_c+100 kHz. Spurious frequencies above -90 dBc are not allowed.

1. Position the Antenna Unit in the position [$X = 0$, $Y = 0$, $Z =$ nominal height].
2. Set the RF switches so that the signal from the Reference Loop is connected to the spectrum analyser.
3. Command the BTM function to its normal operational mode regarding CW Tele-powering, or to any other mode equivalent to this (from the point of view of the Tele-powering evaluation).
4. Measure and record the below defined properties of the Tele-powering signal.
 - Frequency of the 27.095 MHz field.
 - Carrier Noise of the 27.095 MHz field.
5. Repeat steps 1 through 5 for upper and lower temperature extremes.

5.2.6.4 Test Procedure, Interoperable Mode

Test set-up in accordance with sub-clause 5.2.6.2 on page 135 applies.

This test is only applicable to equipment having the ability to operate in Interoperability mode.

1. Position the Antenna Unit in the position [$X = 0$, $Y = 0$, $Z = \text{nominal height}$].
2. Set the RF switches so that the signal from the Reference Loop is connected to the oscilloscope for verifying all properties except for the Modulation Frequency. Verification of Modulation Frequency shall be performed with the RF switches positioned such that the signal from the Reference Loop is connected to the spectrum analyser.
3. Command the BTM function to its normal operational mode regarding toggling Tele-powering, or to any other mode equivalent to this (from the point of view of the Tele-powering evaluation).
4. Measure and record the below defined modulation properties of the Tele-powering signal.
 - Toggling behaviour
 - Modulation Frequency
 - Pulse Width
 - Jitter
 - Modulation Depth
 - Overshoot
5. Repeat steps 1 through 5 for upper and lower temperature extremes.

Modulation characteristic requirements are defined by UNISIG SUBSET-036.

Verification of Modulation Frequency shall be performed using the method described in sub-clause D6.2.2.3.2 on page 267.

5.2.6.5 Acceptance Criteria, Electrical Tele-powering Characteristics

5.2.6.5.1 CW mode

The requirements according to sub-clause 6.2.1.2.1 of UNISIG SUBSET-036 apply.

5.2.6.5.2 Interoperability mode

The requirements according to sub-clause 6.2.1.2.2 of UNISIG SUBSET-036 apply.

5.2.7 Maximum Flux Level

5.2.7.1 General Description

The purpose of this test is to systematically evaluate the performance of the Tele-powering signal generated by the Antenna Unit - BTM function combination. The maximum flux generated through a Reference Loop is subject to testing.

The output signal shall be evaluated during static conditions in CW mode and Interoperability mode (if supported by the equipment under test) respectively. The output signal shall be measured using a Reference Loop. The Reference Loop should be subjected to various load conditions during maximum flux measurements.

The BTM function shall be forced to applicable modes using suitable commands inserted via Interface V₁.

Geometrical test points and applicable test conditions are defined by sub-clauses C7.1 on page 212 and C7.2 on page 213.

The maximum flux level test shall determine the flux level through the Reference Loop under various load conditions, and for various geometrical test points. Three different load conditions apply, 60 Ω (40 Ω), j60 Ω (j40 Ω), and -j60 Ω (-j40 Ω). The figures within parenthesis apply to the Reduced Size Reference Loop, and the others to the Standard Size Reference Loop. Geometrical test points are defined by sub-clause C7.2 on page 213.

The following load tolerances apply:

- Real part of a resistive load $\pm 2 \Omega$
- Imaginary part of a real load $\pm j2 \Omega$
- Real part of an imaginary load for Standard Size RL 3 Ω to 5.5 Ω
- Real part of an imaginary load for Reduced Size RL 2 Ω to 4.5 Ω
- Imaginary part of an imaginary load $\pm j2 \Omega$

5.2.7.2 Test Set-up for Maximum Flux Level verification

The test set-up is shown in Figure 44 below. Clause F1 of Annex F on page 297 gives an example of suitable test equipment.

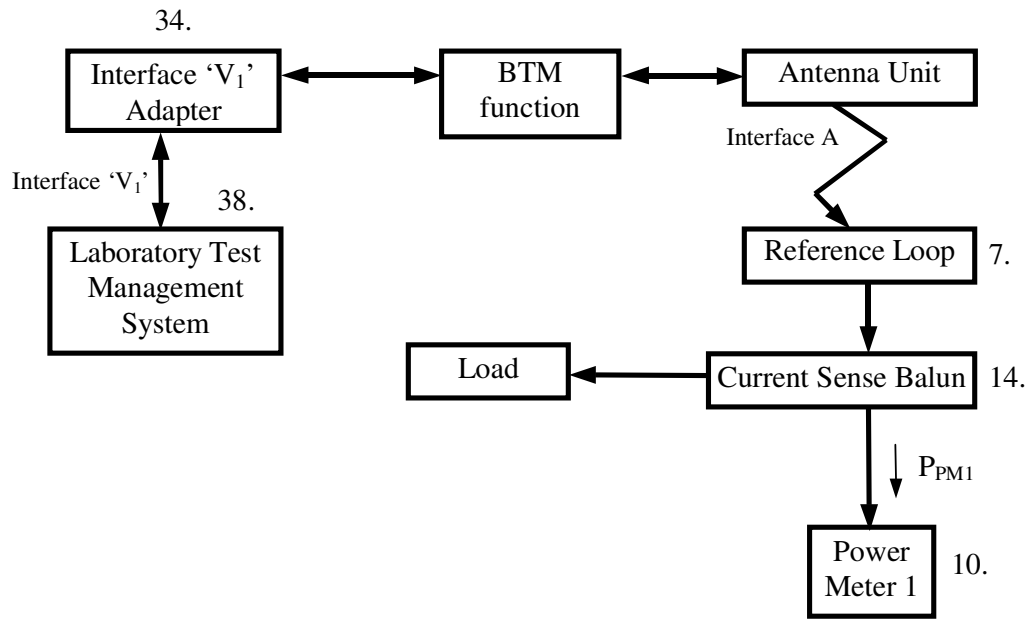

Figure 44: Test set-up for Maximum Flux Level Tests

Item 10, is computer controlled via the Laboratory Test Management System (the computer control is intentionally not indicated in the figure).

5.2.7.3 Test Procedure, Maximum Flux Level

The test set-up in accordance with sub-clause 5.2.7.2 on page 139 applies.

1. Connect the equipment as defined by sub-clause 5.2.7.2 on page 139, and ensure that the Current Sense Balun is calibrated as defined by sub-clause H5.5 on page 330.
2. Connect a load to the Reference Loop forming a total impedance of 60 Ω (40 Ω) in the circuit (i.e., the sum of the Reference Loop impedance and the external load and the Current Sense Balun shall be 60 Ω or 40 Ω).
3. Position the Antenna Unit in the geometrical test point [X = 0, Y = 0, Z = minimum height].
4. Command the BTM function to its normal operational mode regarding CW Tele-powering, or to any other mode equivalent to this (from the point of view of the maximum flux level evaluation).
5. Record the power level of power meter 1 (P_{PM1}).
6. Calculate the flux through the Reference Loop using the following equation:

$$\Phi = \frac{\sqrt{P_{PM1}} \cdot B \cdot (Z_{load} + Z_{loop})}{\sqrt{k \cdot |Z_A|} \cdot 2 \cdot \pi \cdot f_{27}}$$

where: P_{PM1} is power in Watt recorded by power meter 1
B is the Reference Loop transfer matching ratio
 Z_{loop} is the actual impedance of the Reference Loop in the absence of any antenna
 Z_{load} is the external load impedance connected to the Reference Loop
 f_{27} is the Tele-powering frequency (27.095 MHz)
k is the calibration factor determined by sub-clause H5.5 on page 330
 Z_A is defined in sub-clause H5.5 on page 330

7. Perform steps 5 and 6 for all the other geometrical test points defined by sub-clause C7.2 on page 213.
8. Repeat steps 2 through 7, but connect a load forming a total circuit impedance of j60 Ω (j40 Ω) to the Reference Loop.
9. Repeat steps 2 through 7, but connect a load forming a total circuit impedance of -j60 Ω (-j40 Ω) to the Reference Loop.
10. Repeat steps 2 through 9 for the specific condition “Metallic Plane underneath the Reference Loop” defined by sub-clause 5.2.2.2.3 on page 118.

Please observe that the actual load values defined in this test procedure constitute the total load of the circuit. It means that a certain load defined above (e.g., 60 Ω) is the sum of the external load connected to the Reference Loop, the influence of the Current Sense Balun, and the actual Reference Loop impedance. Hence, the Reference Loop impedance has to be measured separately, and the impedance of the combination of the Current Sense Balun and the external load has to be measured separately, and the total impedance has to be calculated (and shall be for instance 60 Ω). This has to be characterised prior to the test.

5.2.7.4 Acceptance Criteria, Maximum Flux Level

The requirement is that the flux level never exceeds ϕ_{d4} .

5.2.8 Electrical Up-link Signal Characteristics

5.2.8.1 General Description

The purpose of this test is to systematically evaluate the BTM function capability with respect to extremes of the electrical characteristics of the Up-link signal (such as centre frequency, frequency deviation, data rate, phase jitter, and amplitude jitter). Suitable test patterns shall be generated by the arbitrary generator in order to test the properties mentioned above.

The input signal to the Reference Loop generating the Up-link signal shall be an FSK signal with “imperfections” as described above. Furthermore, an additional modulation in accordance with sub-clause 5.2.4 on page 124 shall be present in order to simulate a Balise passage. Test data from sub-clauses 5.2.3 on page 120 and 5.2.4 on page 124 shall be used for creation of the simulated Balise passage. The BTM function shall be set in normal operational mode.

Only a limited amount of combinations of lateral deviation and vertical height will be considered (see sub-clause C7.2 on page 213). The BTM function output signal shall be observed via Interface V_1 and evaluated.

The criteria for the Antenna Unit - BTM function being able to correctly handle a certain sequence are defined in paragraph 5 of sub-clause 5.2.5.1 on page 130.

Test Conditions shall be in accordance with sub-clause C7.1 on page 212.

5.2.8.2 Test Procedure, Electrical Up-link Characteristics

Test set-up in accordance with sub-clause 5.2.1.2 on page 114 applies.

Suitable test patterns for the arbitrary generator shall be developed that simulates the following extremes of the Up-link signal:

- Centre frequency = 4.234 MHz \pm 175 kHz.
- Frequency Deviation = 282.24 kHz \pm 7 %.
- Mean Data Rate = 564.48 kbit/s \pm 2.5 %.
- Limits of MTIE requirement 1 and requirement 2 according to UNISIG SUBSET-036.
- Amplitude Jitter = +1.5/-2.0 dB.

Please note that the test patterns shall be designed in order to comply with testing of the Up-link signal from the Balise as defined in sub-clause 4.2.7 on page 72. One main aspect as listed above shall be evaluated at a time. Start-up and steady state behaviour shall be considered where applicable.

Apart from these modifications of the FSK signal and the selection of geometrical test points and test conditions, the test procedure is identical to the procedure defined in sub-clause 5.2.5.2 on page 131 (Transmission Tests).

Geometrical test points and test conditions are defined by clause C7.1 on page 212, and clause C7.2 on page 213.

5.2.8.3 Test Cases

Parameter	Case 1	Case 2	Case 3	Case 4	Case 5
Centre Frequency	4.409 MHz	Nominal	Nominal	Nominal	Nominal
Frequency Deviation	Nominal	302.0 kHz	Nominal	Nominal	Nominal
Mean Data Rate	Nominal	Nominal	578.6 kbits/s	Nominal	Nominal
MTIE	Nominal	Nominal	Nominal	MTIE2 limits ²⁴	Nominal
Amplitude Jitter	Nominal	Nominal	Nominal	Nominal	+1.5/-2.0 dB ²⁵
Parameter	Case 6	Case 7	Case 8	Case 9	
Centre Frequency	4.059 MHz	Nominal	Nominal	Nominal	
Frequency Deviation	Nominal	262.4 kHz	Nominal	Nominal	
Mean Data Rate	Nominal	Nominal	550.4 kbits/s	Nominal	
MTIE	Nominal	Nominal	Nominal	MTIE1 limits ²⁴	
Amplitude Jitter	Nominal	Nominal	Nominal	Nominal	

Table 21: Test Cases

Nominal characteristics for the respective parameter are defined in sub-clause 5.2.2.1.4 on page 117.

Please observe that the implementation of the test patterns shall consider potential inaccuracy of the RSG/LRRT and the rest of the test set-up such that it is guaranteed that the specified limits are never exceeded. Air-gap properties shall be verified using the already used 4.2 MHz antenna (used during Balise testing).

5.2.8.4 Acceptance Criteria, Electrical Up-link Characteristics

See sub-clause 5.2.5.3 on page 134.

²⁴ As defined in Part 1 of this Norm. Three different cases using triangular simulated jitter patterns apply. The first should be with a period of 3 bits, the second with a period of 25 bits, and the third with a period of 1000 bits.

²⁵ The jitter should be such that it is correlated with the bit transitions. Low and high jitter frequencies should apply. Low jitter frequency is such that three jitter periods occur within an entire telegram. High frequency jitter is such that the amplitude changes every three data bits.

5.2.9 Cross-talk Immunity

5.2.9.1 General Description

Cross-talk tests shall determine whether there are any potential cross-talk situations within the defined geometrical region and during the test conditions defined by sub-clause 5.2.2 on page 116. Where applicable, certain cross-talk margins should be evaluated. Specific cable related cross-talk is not included in this sub-clause, but separately dealt with in 5.2.10 on page 146.

The Tele-powering flux shall be measured using a Reference Loop. The recorded flux level (ϕ) shall after this be used for determining the response from a strongest worst case Balise (I_{HIGH}) utilising the upper limits of the transfer response curve defined by UNISIG SUBSET-036. Thereafter, the Reference Loop shall be connected to a signal generator generating an FSK Up-link signal that simulates a representative Balise passage (see Figure 45 below), and carrying a correct telegram with a peak current level as determined above (I_{HIGH}). The BTM function output response shall be observed via Interface 'V₁'. The requirement is that no Balise detection is reported. Thereafter, the peak current level shall be gradually increased until Balise detection occurs, or until a peak current value of $I_{U3} + 20$ dB is reached. The procedure is similar to the method described in sub-clause 5.2.3.1 on page 120. The difference is that current levels up to the maximum peak current level $I_{U3} + 20$ dB are quantitatively tested to evaluate the margin for cross-talk.

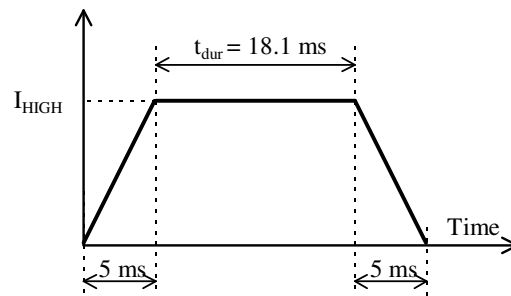

Figure 45: Up-link signal for Cross-talk tests

The time t_{dur} shall be selected so that ten complete 1023 bit telegrams are transmitted. The odometer input signal shall be selected so that the flat part of the sequence according to Figure 45 above corresponds to approximately 0.5 m at a speed of 100 km/h (the entire sequence from start of rising edge to end of falling edge corresponds to approximately 0.78 m).

This procedure shall be performed for all the geometrical positions defined by clause C5 on page 209, and for all test conditions defined by sub-clause 5.2.2 on page 116. Certain tailoring is defined by clause C6 on page 210.

5.2.9.2 Test Procedure, Cross-talk Immunity

Test set-up in accordance with sub-clause 5.2.1.2 on page 114 applies.

1. Position the Antenna Unit in the first geometrical test point defined by clause C5 on page 209 and select nominal test conditions defined by sub-clause 5.2.2.1 on page 116.
2. Set the RF switch in position P2.
3. Command the BTM function to its normal operational mode regarding CW Tele-powering, or to any other mode equivalent to this (from the point of view of the Cross-talk evaluation).
4. Record the value of power meter 2.
5. Repeat step 4 for all remaining geometrical test points defined by clause C5 on page 209 and clause C6 on page 210.
6. Calculate the flux for all geometrical test points using the equation defined in sub-clause 5.2.3.2 on page 122.
7. Determine the corresponding worst case (strongest) response from the Balise (I_{HIGH}) as described in sub-clause 5.2.9.1 on page 143.
8. Set the RF switch in position P1.
9. Set the arbitrary generator to generate an Up-link signal in accordance with Figure 45 on page 143. The initial current setting shall be the I_{u3} current. The current is measured by the Vector Signal Analyser, and the related transfer response of the Current Sense Balun is in accordance with sub-clause H5.4 on page 329. Please observe that the current measured by the Vector Signal Analyser needs to be compensated for the B-factor of the Reference Loop (i.e., the measured target current shall be the desired Reference Loop current divided by B). Set the time and odometer information to comply with a speed of 100 km/h.
10. Position the Antenna Unit in the first geometrical test point defined by clause C5 on page 209 and select nominal test conditions defined by sub-clause 5.2.2.1 on page 116.
11. Record the output from the BTM function (via Interface 'V₁') and determine whether Balise detection occurred or not. That is, Balise detect or Balise localisation is reported.
12. In case that Balise detect did not occur, increase the peak current level in steps of 0.5 dB until Balise detect occurs or until $I_{u3} + 20$ dB is reached. Repeat steps 11 and 12 until the margin is determined.
13. Repeat steps 11 and 12 for all remaining geometrical test points defined by clause C5 on page 209 and clause C6 on page 210, using the appropriate I_{HIGH} for each separate point.
14. Repeat steps 1 through 13 for all specific test conditions defined by sub-clause 5.2.2.2 on page 118 and clause C6 on page 210. Please observe that "nominal conditions" of step 1 is substituted by the relevant "specific condition" for each subsequent pass.

It must be verified that reliable Up-link measurements can be performed in the presence of the applicable 27 MHz Tele-powering signal.

5.2.9.3 Acceptance Criteria, Cross-talk Immunity

5.2.9.3.1 General

The requirement is that no cross-talk occurs. There is no explicit requirement on a certain margin, but the defined test procedure makes it possible to perform this evaluation. The evaluation of the cross-talk margin must be separated into the two cases defined by UNISIG SUBSET-036.

5.2.9.3.2 One Balise and one Antenna Unit

This case is applicable for lateral deviations of 1400 mm or more.

The cross-talk margin in dB is evaluated as follows:

$$Margin = \{\Phi \leq \Phi_{d3}\} = 20 \cdot \log \frac{I_{CT}}{I_{u3}} + 20 \cdot \log \frac{\Phi_{d3}}{\Phi}$$

$$Margin = \{\Phi > \Phi_{d3}\} = 20 \cdot \log \frac{I_{CT}}{I_{u3}}$$

Where: Φ is the actual flux level in nVs for the geometrical position in question
 Φ_{d3} is in nVs, and defined by the transfer characteristics of the Balise
 I_{CT} is the actual current in mA for when cross-talk occurs
 I_{u3} is in mA, and defined by the transfer characteristics of the Balise
Margin is the cross-talk margin in dB

5.2.9.3.3 One Balise and two Antenna Units

This case is applicable for lateral deviations of 3000 mm or more, and for longitudinal deviations as defined by the manufacturer of the Antenna Unit.

The cross-talk margin in dB is evaluated as follows:

$$Margin = 20 \cdot \log \frac{I_{CT}}{I_{u3}}$$

Where: I_{CT} is the actual current in mA for when cross-talk occurs
 I_{u3} is in mA, and defined by the transfer characteristics of the Balise
Margin is the cross-talk margin in dB

5.2.10 Cross-talk Immunity with Cables

5.2.10.1 General

This sub-clause defines measurement methods for verifying potential cable related cross talk for the Antenna Unit. The tests are divided in two parts:

- Up-Link Cross talk from cable to Antenna
- Tele-powering Cross talk from Antenna to cable

It also includes the test set-ups that are required.

All distances are in millimetres unless explicitly otherwise stated.

5.2.10.2 Cross-talk Measurements

5.2.10.2.1 Test Configuration, Up-Link Cross-talk from cable to Antenna Unit

A proposed test set-up is shown in Figure 46 below. Clause F1 of Annex F on page 297 gives an example of suitable test equipment. See also sub-clause 4.2.1 on page 23.

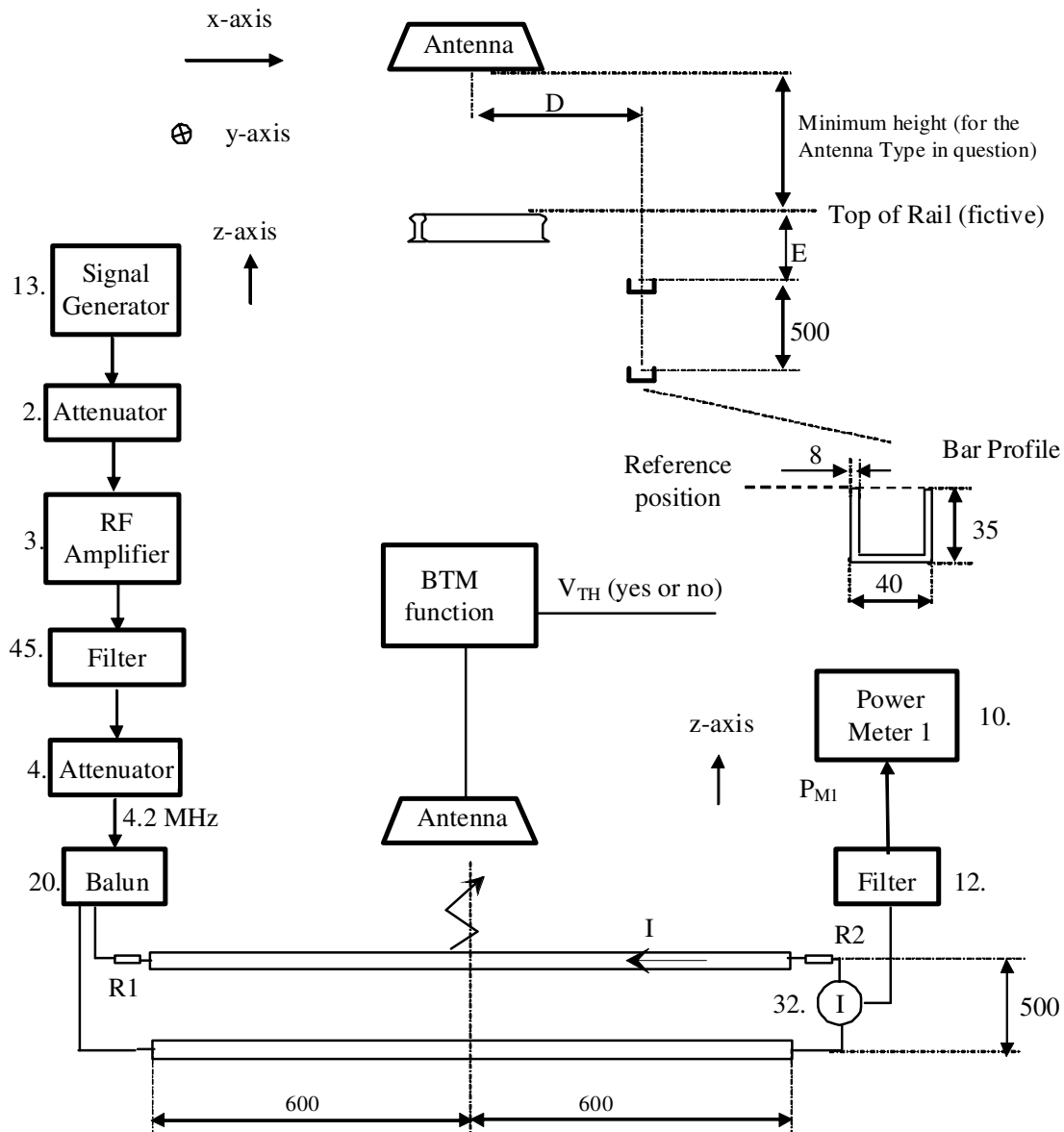

Figure 46: Up-link Test Configuration, cable to Antenna Unit

5.2.10.2.2 Test Configuration, Tele-powering Cross-talk from Antenna Unit to cable

A proposed test set-up is shown in Figure 47 below. Clause F1 of Annex F on page 297 gives an example of suitable test equipment. See also sub-clause 4.2.1 on page 23.

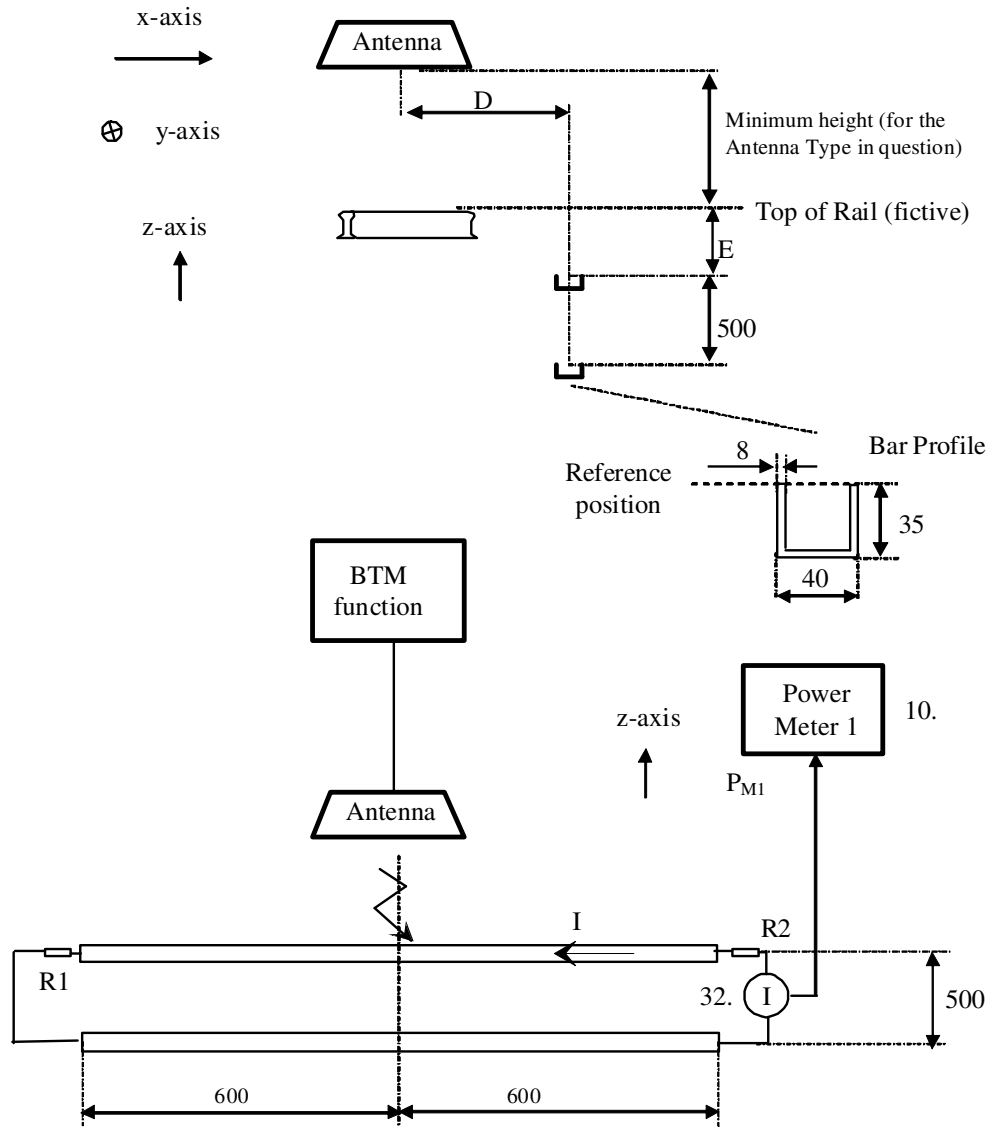

Figure 47: Tele-powering Test Configuration, Antenna Unit to cable

5.2.10.2.3 Test Procedure, Up-link Cross-talk from cable to Antenna Unit

The test set-up shown in Figure 46 on page 147 shall be used. The resistor R1 shall be 350 Ω and R2 shall be 400 Ω . The distance D is the position in the x direction, and shall be in the range from -1000 mm to 1000 mm. This test determines the signal received in an Antenna induced from a cable with the current 2 mA and 10 mA for E = 93 mm and E = 493 mm respectively. See Figure 46 on page 147 for definition of E.

1. Position the Antenna at position D = -1000 mm and E = 93 mm and set the BTM function in normal operational mode.
2. Set the Signal Generator to generate a 4.2 MHz FSK signal carrying telegram type 1, and the current 'I' to 2 mA. For telegram type 1 see clause A2 of Annex A on page 161. For the suggested current probe, a current of 1 mA will give a voltage of 1 mV into 50 Ω . Therefore, the current is calculated using the following equation:

$$I = \sqrt{P_{M1} \times 50} \quad \text{Where P is measured in [W], and I is measured in [A]}$$

3. Verify that the response from the Antenna Unit is below V_{th} (determined by the BTM function) by observing output data via Interface V_1 (i.e., that Balise detect or Balise localisation is not reported).
4. Position the Antenna at regular intervals of +40 mm, up to the distance D = 1000 mm. For each position, verify that the response is below V_{th} .
5. Position the Antenna at position D = -1000 mm and E = 493 mm.
6. Set the Signal Generator to generate a 4.2 MHz FSK signal carrying telegram type 1, and the current 'I' to 10 mA. For telegram type 1 see clause A2 of Annex A on page 161.
7. Verify that the response from the Antenna Unit is below V_{th} (determined by the BTM function) by observing output data via Interface V_1 (i.e., that Balise detect or Balise localisation is not reported).
8. Position the Antenna at regular intervals of +40 mm, up to the distance D = 1000 mm. For each position, verify that the response is below V_{th} .

5.2.10.2.4 Test Procedure, Tele-powering Cross-talk from Antenna Unit to cable

The test set-up shown in Figure 47 on page 148 shall be used. The resistor R1 shall be 400 Ω , and R2 shall be 400 Ω . The distance D is the position in the x direction, and shall be in the range from -1000 mm to 1000 mm. This test determines the current induced in a cable from an Antenna Unit for E = 93 mm and E = 493 mm. See Figure 47 on page 148 for definition of E.

1. Position the Antenna at position D = -1000 mm and E = 93 mm.
2. Command the BTM function to its normal operational mode regarding CW Tele-powering, or to any other mode equivalent to this (from the point of view of the Cross-talk evaluation).
3. Record the reading of Power Meter 1 and call it P_{27IACH} .
4. Position the Antenna at regular intervals of +40 mm, up to the distance D = 1000 mm. For each position, record the reading of Power Meter 1 and call it P_{27IACH} .
5. Position the Antenna at position D = -1000 mm and E = 493 mm.
6. Record the reading of Power Meter 1 and call it P_{27IACL} .
7. Position the Antenna at regular intervals of +40 mm, up to the distance D = 1000 mm. For each position, record the reading of Power Meter 1 and call it P_{27IACL} .

The results from the test are a set of P_{27IACH} values and a set of P_{27IACL} . Calculate the current that corresponds to the maximum value of each set of data, and call them I_{27ACH} and I_{27ACL} respectively. For the suggested current probe, the current of 1 mA will give a voltage of 1 mV into 50 Ω . Therefore, the currents are calculated with the following equations:

$$I_{27ACH} = \sqrt{P_{27IACH} \times 50} \quad \text{Where P is measured in [W], and I is measured in [A]}$$

$$I_{27ACL} = \sqrt{P_{27IACL} \times 50} \quad \text{Where P is measured in [W], and I is measured in [A]}$$

The value I_{27ACH} shall be lower than 25 mA.

The value I_{27ACL} shall be lower than 10 mA.

5.2.10.3 LZB Cable Testing

5.2.10.3.1 General

In general, two different test set-ups apply for the tests with LZB cable:

- Measurement of 27 MHz Tele-powering induction from a Eurobalise On-board Equipment.
- Measurement on the Eurobalise On-board Equipment when 4.2 MHz current is injected into the tool.

Requirements are defined in UNISIG SUBSET-036.

Please observe that the 75 Ω set-up impedance must always remain for the purpose of testing of Tele-powering induction.

5.2.10.3.2 Reference Axes and Origin of Co-ordinates

Regarding measurements with 4.2 MHz Up-link current, directions for the Antenna Unit shall be defined according to three reference axes related to the horizontally placed LZB Test Loop described in sub-clause J2.3 on page 335.

- A reference axis in parallel with the longer side of the LZB Test Loop (the X-axis).
- A reference axis at right angles to the X-axis. This axis is in parallel with the short side and crosses the long side of the LZB Test Loop in the middle. The level of this axis is the centre of the LZB cable (the Y-axis).
- A reference axis directed upwards, at right angles to the LZB Test Loop plane (the Z-axis).

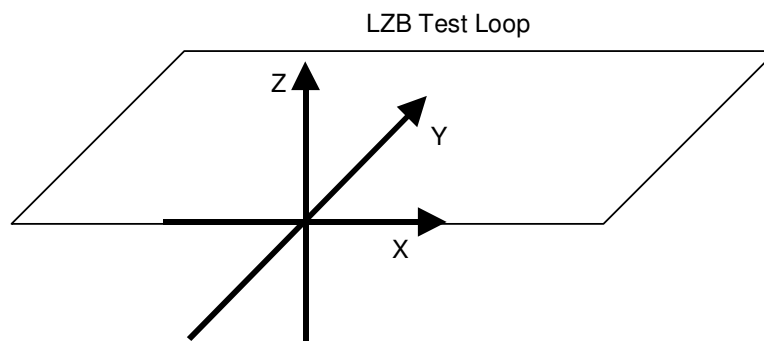

Figure 48: Reference Axes

5.2.10.3.3 Test set-up for 27 MHz Induction

The test set-up according to Figure 49 below applies. Clause F1 of Annex F on page 297 gives an example of suitable test equipment. Additional details related to the vertically positioned LZB loop is found in sub-clause J2.4 on page 338. See also sub-clause 4.2.1 on page 23.

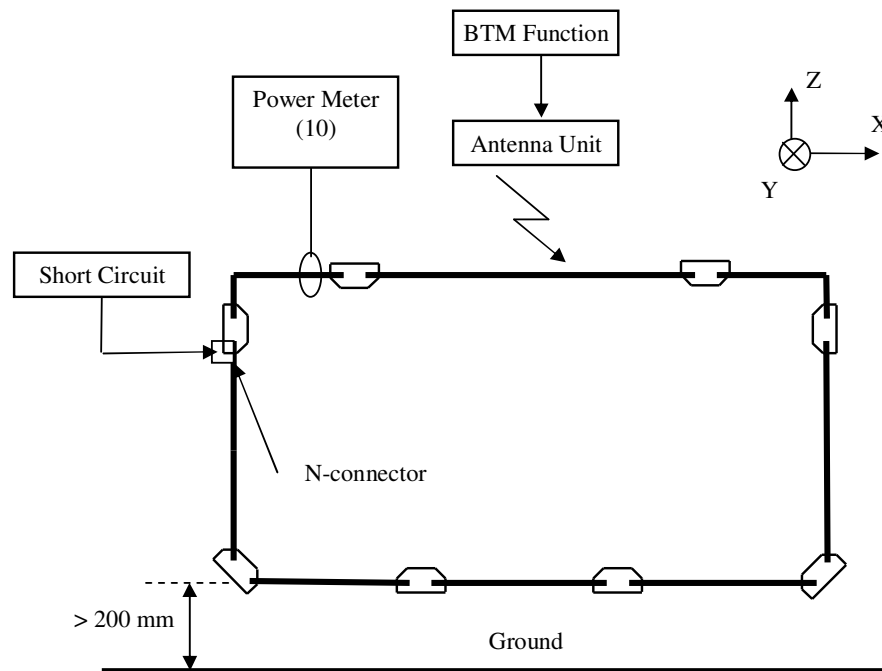

Figure 49: Test set-up, Tele-powering induction from the antenna

5.2.10.3.4 Test procedure for 27 MHz Induction

The recommended test set-up of sub-clause 5.2.10.3.3 should be used. The following procedure applies:

1. Position the On-board Antenna Unit at the position $X = 0$, $Y = -300$, and at the height representing the minimum antenna height defined by the supplier combined with an LZB cable position 105 mm below the Top of Rail. The reference position of the tool ($X = 0$, $Y = 0$, $Z = 0$) is at the midpoint of the longer upper horizontal cable segment of the tool.
2. Set the On-board equipment into normal operation.
3. Measure the 27 MHz current induced into the LZB loop.
4. Repeat step 3 for increasing Y co-ordinates in steps of 20 mm up to a maximum of $Y = 300$.
5. Repeat steps 1 through 4 for an antenna height considering the case of the LZB cable positioned 75 mm below the Top of Rail.
6. Verify that the limits defined in UNISIG SUBSET-036 are not exceeded.

Please observe that the balun shall be the same unit as the one used during tuning of the LZB loop.

5.2.10.3.5 Test set-up for 4.2 MHz Injection

A recommended test set up is in accordance with Figure 50 below. Clause F1 of Annex F on page 297 gives an example of suitable test equipment. Additional details related to the horizontally positioned LZB loop is found in sub-clause J2.3 on page 335. See also sub-clause 4.2.1 on page 23.

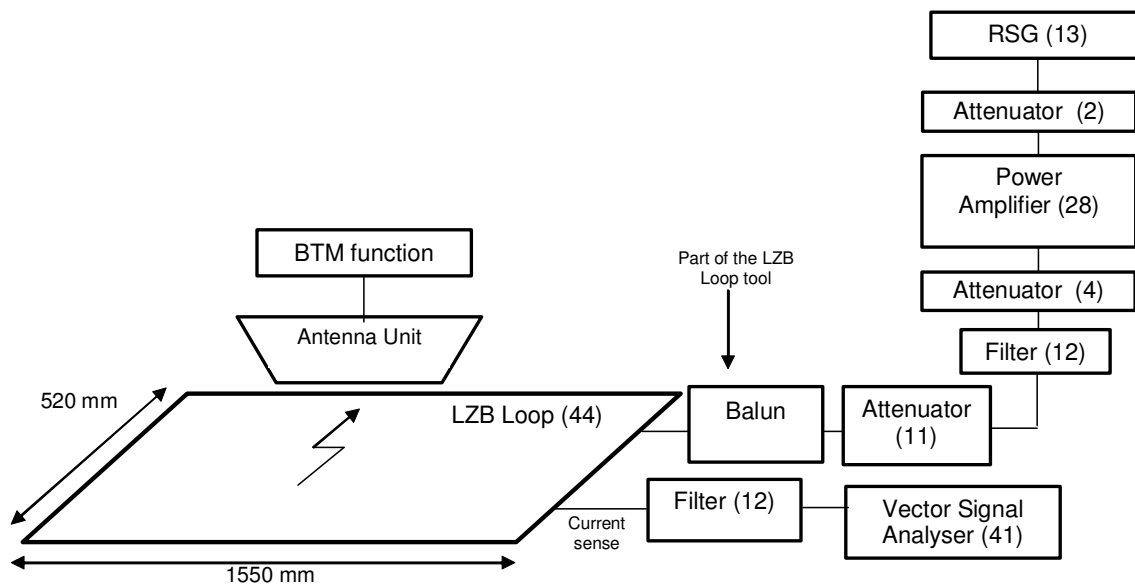

Figure 50: Test set-up for 4.2 MHz Injection

5.2.10.3.6 Test procedure for 4.2 MHz Injection

The recommended test set-up of sub-clause 5.2.10.3.5 should be used. The following procedure applies:

1. Generate an Up-link signal including telegram 17 (defined in Table 25 on page 164), modulated in accordance with sub-clause 5.2.9.1 on page 143, by the RSG. Adjust the output level (I_{HIGH} in sub-clause 5.2.9.1) to result in 0.3 mA through the LZB Loop. Please observe that Tele-powering shall be switched off during the adjustments of the current.
2. Position the On-board antenna at the position $X = 0$, $Y = -300$, and at the height representing the minimum antenna height defined by the supplier combined with an LZB cable position 75 mm below the Top of Rail. The reference position of the tool ($X = 0$) is at the midpoint of one of the longer cable segment of the tool.
3. Set the On-board equipment into normal operation.
4. Verify that the On-board equipment does not detect the signal.
5. Repeat steps 2 through 4 for increasing Y co-ordinates in steps of 20 mm up to a maximum of $Y = 300$.

5.2.11 Balise Detectability Supervision

5.2.11.1 General Description

This test may be performed in a dynamic way if the Antenna Unit - BTM function combination requires this to operate properly. In this case, time and odometer information may be required. Antenna mounting conditions shall be specified by the supplier.

The test shall be performed with the Reference Loop substituted by the metallic profile defined by “Metallic masses in the track” according to sub-clause 5.2.2.2.3 on page 118. The Antenna Unit shall first be positioned directly above the metallic profile ($X = 0$, $Y = 0$) at the minimum height specified by the supplier. No other debris or metallic objects shall be present during this test.

In case the alarm is not triggered, then the distance ‘d’ (according to sub-clause 5.2.2.2.3 on page 118) shall be gradually increased in steps of 20 mm until an alarm is achieved. A maximum of three 20 mm steps shall be taken during this process.. In case the alarm is triggered the same procedure shall be performed but for decreasing ‘d’ distances in the same manner.

5.2.11.2 Acceptance Criteria, Balise Detectability Supervision

The requirement is that no alarm is triggered at Antenna Unit heights higher than specified by the supplier.

5.2.12 Handling of various Telegrams

5.2.12.1 General Description

The purpose of this test is to systematically evaluate the BTM function capability with respect to handling of various types of telegrams (including telegram switching).

The input signal to the Reference Loop generating the Up-link signal shall be in accordance with results from sub-clause 5.2.4 on page 124. The time scale shall be selected in order to comply with the maximum specified velocity for the lateral deviation (Y position) to be tested (except for during tests of telegram switching at very low speed). The odometer input signal shall be selected accordingly. The BTM function shall be set in normal operational mode.

Only a limited amount of combinations of lateral deviation and vertical height will be considered (see sub-clause C7.2 on page 213). The BTM function output signal shall be observed via Interface V₁ and evaluated.

The criteria for the Antenna Unit - BTM function being able to correctly handle a certain sequence are defined in paragraph 5 of sub-clause 5.2.5.1 on page 130.

Test Conditions shall be in accordance with sub-clause C7.1 on page 212.

Telegrams shall be selected among those defined by clause A2 of Annex A on page 161. Telegram switching shall be tested both at high speed, and very low speed conditions (contact time more than 100 ms).

5.2.12.2 Test Procedure, Handling of various Telegrams

Test set-up in accordance with sub-clause 5.2.1.2 on page 114 applies.

Suitable test patterns for the arbitrary generator shall be developed that perform transmission of the various telegram types defined by clause A2 of Annex A on page 161. One single telegram type shall be evaluated at a time. Test of telegram switching shall be performed during simulation of maximum speed as well as during very low speed conditions.

Apart from these modifications of the FSK signal and the selection of geometrical test points and test conditions, the test procedure is identical to the procedure defined in sub-clause 5.2.5.2 on page 131 (Transmission Tests).

Geometrical test points and test conditions are defined by sub-clause C7.1 on page 212 and C7.2 on page 213.

5.2.12.3 Acceptance Criteria, Handling of various Telegrams

See sub-clause 5.2.5.3 on page 134.

5.2.13 Handling of Balise Sequences

5.2.13.1 General Description

The purpose of this test is to verify that the BTM function correctly reports a sequence of Balises within a Balise group. The BTM function shall be set in normal operational mode.

The input signal to the Reference Loop generating the Up-link signal shall be in accordance with results from sub-clause 5.2.4 on page 124, but consist of a sequence of eight consecutive Standard Size Balises positioned at the minimum specified distance between each other. The time scale shall be selected in order to comply with the maximum specified velocity for the lateral deviation (Y position) to be tested. The time and odometer input signal shall be selected accordingly. Different telegrams and different lengths of telegrams shall be mixed within the sequence of eight Balises. Telegrams shall be selected among those defined by clause A2 of Annex A on page 161.

Only a limited amount of combinations of lateral deviation and vertical height will be considered. The BTM function output signal shall be observed via Interface V_1 and evaluated.

The criteria for the Antenna Unit - BTM function being able to correctly handle a certain sequence are defined in paragraph 5 of sub-clause 5.2.5.1 on page 130. See also paragraph 6 of sub-clause 5.2.5.1 on page 130

Geometrical test points and Test Conditions are defined by sub clauses C7.1 on page 212 and C7.2 on page 213.

5.2.13.2 Test Procedure, Handling of Balise Sequences

Test set-up in accordance with sub-clause 5.2.1.2 on page 114 applies.

Suitable test patterns for the arbitrary generator shall be developed that simulates a sequence of eight Standard Size Balises carrying a mix of different telegrams. The following order of telegrams applies:

- Balise 1 - Telegram type 8.
- Balise 2 - Telegram type 1.
- Balise 3 - Telegram type 9.
- Balise 4 - Telegram type 2.
- Balise 5 - Telegram type 10.
- Balise 6 - Telegram type 3.
- Balise 7 - Telegram type 11.
- Balise 8 - Telegram type 4.

Apart from these modifications of the FSK signal and the selection of geometrical test points and test conditions, the test procedure is identical to the procedure defined in sub-clause 5.2.5.2 on page 131 (Transmission Tests). The additional modulation simulating the Balise passage includes eight consecutive patterns as defined in sub-clause 5.2.4 on page 124. The distance between the centres of consecutive Balises shall be set according to:

- 2.6 m when simulating a speed of 180 km/h
- 3.0 m when simulating a speed of 300 km/h
- 5.0 m when simulating a manufacturer dependent speed above 300 km/h

Geometrical test points and Test Conditions are defined by sub clauses C7.1 on page 212 and C7.2 on page 213.

5.2.13.3 Acceptance Criteria, Handling of Balise Sequences

See sub-clause 5.2.5.3 on page 134. Additionally, the simulated order of Balises must not be mixed.

5.2.14 Fundamental concepts of Basic Receiver

5.2.14.1 General Description

The purpose of this test is to check the fundamental concepts of the Basic Receiver defined in sub-clause 4.3.4 of UNISIG SUBSET-036.

For the purpose of the tests, the specific set of test telegrams defined in clause A3 on page 166 shall be used. It should be observed that a complete test of all the requirements of the Basic Receiver is more extensive, and that this procedure focuses on the most important and fundamental requirements defined sub-clause 4.3.4 of UNISIG SUBSET-036.

The test telegrams can not prove the safety of the receiver, but they do detect violation of the most obvious and critical properties (such as inversion of telegram, as well as the proper handling of synchronisation bits, check bits and extra bits).

The test telegrams of clause A3 on page 166 are 1023 or 341 bits long. All test telegrams may be transmitted cyclically without interruptions between the last and the first bits of the telegram.

Two of the test telegrams are valid inverted telegrams. The Basic Receiver shall reject the other six test telegrams. In fact (apart from the extra-bits test, where the exact number of required extra bits is slightly arbitrary), any safe receiver shall reject the defined test telegrams.

The input signal to the Reference Loop generating the Up-link signal shall be in accordance with results from sub-clause 5.2.4 on page 124. The time scale shall be selected in order to comply with the maximum specified velocity for the lateral deviation (Y position) to be tested. The odometer input signal shall be selected accordingly. The BTM function shall be set in normal operational mode.

Only a limited amount of geometrical test points shall be considered (see sub-clause C7.2 on page 213). The BTM function response shall be observed via Interface V_1 and evaluated.

5.2.14.2 Test Procedure, Fundamental concepts of Basic Receiver

Test set-up in accordance with sub-clause 5.2.1.2 on page 114 applies.

Suitable test patterns for the arbitrary generator shall be developed that perform transmission of the various telegram types defined by clause A3 on page 166. One single telegram shall be evaluated at a time.

Apart from these modifications of the FSK signal and the selection of geometrical test points and test conditions, the test procedure is identical to the procedure defined in sub-clause 5.2.5.2 on page 131 (Transmission Tests).

Geometrical test points and test conditions are defined by sub-clauses C7.1 on page 212 and C7.2 on page 213.

5.2.14.3 Acceptance Criteria, Fundamental concepts of Basic Receiver

The telegrams in accordance with clause A3 on page 166 shall be handled as follows:

- The telegram defined as identity S1 shall be either reported as a correctly decoded telegram, or be rejected.
- The telegram defined as identity S2 shall be either reported as a correctly decoded telegram, or be rejected.
- The telegram defined as identity S3 shall be rejected.
- The telegram defined as identity S4 shall be rejected.
- The telegram defined as identity S5 shall be rejected.
- The telegram defined as identity S6 shall be rejected.
- The telegram defined as identity S7 shall be rejected.
- The telegram defined as identity S8 shall be rejected.

5.3 Requirements for Test Tools

See Annex B on page 168, Annex D on page 215, and Annex H on page 309.

Annex A (Normative), Reference Test Telegrams

A1 General

The telegrams entered into the Balise via its Interface 'C1', stored within the Balise (Default Telegram), or entered into the reference loop shall in general contain meaningful user data, consistent with the real, or partly simulated, movement of the antenna. They shall normally contain variables and data compliant with the ERTMS/ETCS language and must be encoded according to the coding requirements defined in UNISIG SUBSET-036. The exception from these rules is that during testing of the fundamental concepts of the Basic Receiver, the specific telegrams of clause A3 on page 166 shall be used, which do not fulfil these criteria

Both lengths of telegrams (341 bits and 1023 bits) are used.

Regarding the test telegrams considered in clause A2 on page 161, a complete list of application related data is given in Table 22. An explanation of their different typologies is given in Table 24. The finally encoded data corresponding to each telegram is given in Table 25, while the final set of "User Data" is given in Table 23. Hexadecimal notation is used for describing both final test telegrams and User Data.

Table 26 gives the characteristics of each test telegram used for testing the Basic Receiver properties. Table 27 gives the final telegram bits in the same way as in Table 25 for normal test telegrams.

For each telegram of Table 25 and Table 27, the corresponding bit sequence can be obtained from the hexadecimal representation by replacing each hexadecimal digit with its four-bit binary digit notation (MSB on the leftmost position). For the short telegrams, the last 3 bits of the corresponding hexadecimal notation of Table 25 and Table 27 shall be ignored. For the long telegrams, the last bit of the corresponding hexadecimal notation of Table 25 and Table 27 shall be ignored. The telegram transmission starts from the first leftmost bit of the string so obtained, and continues from left to right. According to sub-clause 4.3.1.2 of UNISIG SUBSET-036, the first transmitted bit is the MSB of the telegram (bit 340 or bit 1022), while the last transmitted bit is the LSB (bit 0).

The checksum, included in Table 25 and Table 27 related to each telegram, is used for protecting the telegram notation with respect to possible corruption originating from text editing tools. The checksum is built-up by grouping the consecutive hexadecimal digits of each string in a string of hexadecimal two-digit numbers (where the leftmost digit is the most significant one), and by summing up all the two-digit numbers so obtained.

A2 Test Telegrams

Tel. ID	Size	Type	Balise description								
			M_BALISE	M_PIG	M_DUP	M_MCOUNT	M_PACKET	L_PACKET	NID_TRAIN	L_XTEXT	X_TEXT
			8 bits	4 bits	2 bits	8 bits	8 bits	8 bits	20 bits	8 bits	variable
1	Short	2	1000 0000b	0001b	00b	0d	71d (fixed)	xxxxxxx	1d	xxxxxxx	xxxxxxx
2	Short	2	1000 0000b	0010b	00b	0d	71d (fixed)	xxxxxxx	2d	xxxxxxx	xxxxxxx
3	Short	3	1000 0000b	0001b	00b	0d	71d (fixed)	xxxxxxx	3d	xxxxxxx	xxxxxxx
4	Short	3	1000 0000b	0010b	00b	0d	71d (fixed)	xxxxxxx	4d	xxxxxxx	xxxxxxx
5	Short	4	1000 0000b	0000b	00b	0d	71d (fixed)	xxxxxxx	5d	xxxxxxx	xxxxxxx
6	Short	4	1000 0000b	0000b	00b	0d	71d (fixed)	xxxxxxx	6d	xxxxxxx	xxxxxxx
7	Short	5	1000 0000b	0000b	00b	0d	71d (fixed)	xxxxxxx	7d	xxxxxxx	xxxxxxx
8	Short	5	1000 0000b	0000b	00b	0d	71d (fixed)	xxxxxxx	8d	xxxxxxx	xxxxxxx
9	Long	9	1000 0000b	0001b	00b	0d	71d (fixed)	xxxxxxx	9d	xxxxxxx	xxxxxxx
10	Long	9	1000 0000b	0010b	00b	0d	71d (fixed)	xxxxxxx	10d	xxxxxxx	xxxxxxx
11	Long	10	1000 0000b	0001b	00b	0d	71d (fixed)	xxxxxxx	11d	xxxxxxx	xxxxxxx
12	Long	10	1000 0000b	0010b	00b	0d	71d (fixed)	xxxxxxx	12d	xxxxxxx	xxxxxxx
13	Long	11	1000 0000b	0000b	00b	0d	71d (fixed)	xxxxxxx	13d	xxxxxxx	xxxxxxx
14	Long	11	1000 0000b	0000b	00b	0d	71d (fixed)	xxxxxxx	14d	xxxxxxx	xxxxxxx
15	Long	12	1000 0000b	0000b	00b	0d	71d (fixed)	xxxxxxx	15d	xxxxxxx	xxxxxxx
16	Long	12	1000 0000b	0000b	00b	0d	71d (fixed)	xxxxxxx	16d	xxxxxxx	xxxxxxx
17	Short	1	1000 0000b	0000b	00b	0d	71d (fixed)	xxxxxxx	17d	xxxxxxx	xxxxxxx
18	Long	8	1000 0000b	0000b	00b	0d	71d (fixed)	xxxxxxx	18d	xxxxxxx	xxxxxxx

Table 22: User data of the Test Telegrams (before coding)

Type	Description
1	Short Telegram with 50 % (± 2 %) of logical "1" and with an evenly distributed run length
2	Short Telegram with 10 % to 40 % of logical "0" and with an evenly distributed run length
3	Short Telegram with 60 % to 90 % of logical "0" and with an evenly distributed run length
4	Short Telegram with 45 % to 55 % of logical "0" and with high frequency of transitions
5	Short Telegram with 45 % to 55 % of logical "0" and with low frequency of transitions
8	Long Telegram with 50 % (± 2 %) of logical "1" and with an evenly distributed run length
9	Long Telegram with 10 % to 45 % of logical "0" and with an evenly distributed run length
10	Long Telegram with 55 % to 90 % of logical "0" and with an evenly distributed run length
11	Long Telegram with 45 % to 55 % of logical "0" and with high frequency of transitions
12	Long Telegram with 45 % to 55 % of logical "0" and with low frequency of transitions

Table 24: Typologies of the Test Telegrams

ID	Size	Type ²⁶	Check sum	Hexadecimal value
1	Short	2	18D0	75 BB BF 37 1E 7F 76 B9 25 D3 FD ED 46 BA D7 69 85 7B ED 37 F6 A5 F2 F4 3E FD 8C DF 5A 40 DA 7F BB 71 22 C5 BF 22 CD A3 9B 07 78
2	Short	2	1C2D	DD 77 C1 57 C7 E7 F9 79 54 67 A8 B9 BE B1 FE 5F A8 37 D3 B7 A8 CD 2C EF F7 58 DC E6 D6 40 7C E7 B3 25 F8 B3 7B EF 6B 7C DA A8 E0
3	Short	3	1058	0E 50 48 31 9E 85 A1 6B E4 A5 A4 88 A8 06 0A 70 18 A5 73 F0 2B 10 31 08 40 72 30 C0 90 40 72 80 89 22 04 E5 0E 6C 51 57 03 44 80
4	Short	3	0DFB	3B 47 71 49 18 C9 02 16 15 84 09 0C 49 31 C0 C9 0A E7 17 0C A0 44 53 12 66 08 05 83 94 40 48 77 B1 80 8A 58 F2 37 02 07 49 71 30
5	Short	4	12A1	E8 AB AD 7C AA CD 75 66 23 49 71 75 3E 09 19 2E DA 8A 4D 5F 6C 4F 5B A5 51 09 56 CE 5E 40 4D 77 AA 52 B5 98 32 6A 47 51 76 ED 28
6	Short	4	12D9	6D F2 AC D9 28 F5 5B 6F 4B 7F 15 22 AB 70 2C A9 6A D2 1B 52 72 0F 5A 16 99 2A 9D 99 26 40 5B 89 AD 2C A9 53 D3 4B B9 D5 5A 2D 38
7	Short	5	1633	B2 9B EB C1 99 DF 37 80 69 28 BC 6E 06 60 2C 3F 94 37 3F 87 87 79 F7 BB E2 08 1C FE DE 40 71 16 11 C0 2F D2 7C F9 E3 C9 EB 4D 68
8	Short	5	1710	DE FE F3 81 A7 7C 9F BE 05 E4 03 CD B3 BD 62 C7 03 DB B1 8E E3 10 F0 87 67 57 78 20 E0 40 43 8C 10 1E 01 E4 BC 91 60 D3 82 1D F0
9	Long	9	4483	98 3B E6 32 7B 23 75 ED 96 19 46 9A 3D 0E F2 A6 3D 2D 7C 37 88 CD F7 77 C3 DD EB D1 82 65 A7 F5 22 D4 BB D4 75 3A DC 4D 34 2F 5E 63 91 C7 B3 92 96 BA 7D 7B EC DB 14 2F 24 5C 87 F8 EA 7D 3E 0D 2B F6 F2 F1 AB 99 5B 7E DF 45 3C 41 3C AE 77 C2 3B E9 7C 47 5A 7D F2 C5 5D 49 AA F3 30 67 74 FC 4A C7 59 F2 D9 ED 5E F9 13 E2 E6 17 85 92 CD 7B 0F D9 10 1B 51 67 29 2F B5 DF 89 B8 AC DE DA 7C
10	Long	9	473B	BE 09 4B AD 38 41 5F E7 42 D4 6B A0 79 61 36 1B 64 27 9C DF 2B ED 3D E5 BC D9 E2 F6 DF 78 CC 52 E2 B3 16 BC B9 5D CD 8E 73 D7 5B F6 08 B9 0E F5 A3 E5 03 5B 3D D7 B3 15 E4 0C FB 45 55 D6 8F 75 5F 6D 75 1A 4F 7F 69 7C F6 7B 6D 8A 19 3F 4C 07 B7 A9 6E FC 73 F4 C6 EF D4 D8 70 DB F7 EF 79 90 C9 A1 25 8E 67 6E CA D0 E1 C2 69 CE D9 25 AE 0F F1 21 90 11 CD A9 7D BF A5 60 F6 F5 F4 BD 0B D8

²⁶ See definitions in Table 24.

ID	Size	Type ²⁶	Check sum	Hexadecimal value
11	Long	10	36DA	70 88 05 88 70 13 48 B4 43 C0 F0 09 0A 45 D4 CC 19 02 54 BB 81 23 A8 91 CC 2A 41 35 03 DA F1 65 AE 5A 01 4B A8 7A C1 1C 56 1C 1D 6A 22 EE 6A 5D 15 37 E8 44 3D 52 62 1D 41 9E 2B 05 9F 0B 99 F2 8D 95 91 82 97 D6 10 1C 45 39 83 CD 5A 1D 46 F1 51 C0 96 8A 51 32 93 C1 74 81 8E A9 6B 12 03 9B 4E C8 4C F4 B8 6B 3F 68 40 F0 12 C3 2E 86 BE 38 B0 FB 90 3F 09 55 15 86 41 20 6C FA E7 29 86 20
12	Long	10	3834	70 DA 90 A3 DA 44 AF 4B CA E8 D0 F7 08 69 A2 85 7B DC A4 12 C4 88 22 BA F8 29 C1 0C 60 90 F2 1E 23 09 58 21 A0 B8 91 DE 1A E0 21 D2 63 84 51 FD 47 24 A3 84 74 DC A5 ED 37 08 9C 77 12 03 EE 4D B2 97 30 85 40 C4 85 02 E6 E3 48 B5 88 2B 46 31 34 F8 87 09 3F 0C 11 50 CB 28 70 9F 70 11 1E 95 42 10 E4 3A 3C 74 83 51 13 A7 2C 12 D7 69 62 95 08 47 10 10 9F 4F 1F 52 30 D0 3D 0E 4A 10 74 A6
13	Long	11	42E1	A1 E4 F4 35 1A 93 5B 15 44 A2 AB 75 B5 B7 56 B6 80 D5 66 DF 95 EA D3 30 3E 47 CD 15 BB BC 73 85 AC B6 7A 6F 31 DD 37 E8 9B DB 61 EA 24 BD 92 A2 2A 53 A4 69 6A 2A 64 3C CA F6 F6 5D 86 2A 61 7D A7 45 71 38 52 5D 3F C4 83 5A A4 AE 12 AD 15 6E 71 A6 6B 53 96 35 DA 01 F6 6A 93 B4 BC 14 E1 6C DA 7A DA 24 64 D1 0C 6B D2 8D E5 96 EA 18 F4 C4 F8 97 90 12 1C 94 E9 16 F9 8A A3 BC 29 56 63 CC
14	Long	11	4054	12 19 4F 8C C4 FB B5 42 95 6A 9A D2 1A 5B 51 61 C6 A8 E3 FB 88 BA E2 AE 42 73 0C D9 9B E6 09 7D 92 B5 AE 45 A2 AD C6 61 5F 9C D5 5B CA 49 B2 0C 5A B5 22 A5 09 78 71 ED 4E C0 B7 B1 4B 24 FF 0F 40 B1 52 21 D6 0D 96 F2 B7 56 D4 BE 53 ED 29 B1 5D 2F 41 19 34 09 2B 76 AD 51 BC 97 0B A2 75 9A 60 33 A9 89 CE A5 F6 8E 29 7B 53 CF DA 6D D2 DE B6 A8 90 14 2B 2B C8 0A 55 45 E7 40 AA 95 99 5E
15	Long	12	45ED	38 21 B1 BB BE C3 B8 73 C3 86 FC 0D F6 26 B4 C9 54 C7 C7 72 CD F1 C9 26 F4 B8 F8 2A 07 AE 36 E8 78 F0 46 AF 46 88 60 B0 95 58 82 4C 43 9B E3 A1 E4 3C 2F 2F 2D F3 E5 E5 F5 06 D9 A4 25 F2 FB BD 14 F2 1C 27 C7 CA F9 77 D4 84 09 71 0F BD C6 38 A7 86 F3 1F E2 12 D3 0F C1 01 DC 31 98 B3 83 76 38 7E 8E 0C C4 0C B9 BE F8 2D C8 C4 84 07 CB 13 40 C9 90 12 DB 38 88 B9 10 F0 94 F5 8C F6 F9 26
16	Long	12	4234	0E 6C 0C BD B1 B6 03 86 CD E6 59 DF 21 45 7F 50 10 FC CF 02 63 4F CE 32 F2 08 51 64 03 76 97 6E DA 80 CF 9C A2 F4 E3 DB CB E7 57 A8 7E 46 F8 47 4B C0 E3 EF 06 D0 76 7E 81 F9 B8 78 83 03 9B FC EA F5 F7 18 77 74 46 FC 5C 59 52 CF 2E E3 78 D3 12 A6 DC 22 1B 3A CE 57 C4 F0 49 6E 1D C3 82 1A 60 B8 EF 7C F3 07 42 7B 7F 30 FF 7D EE 11 F4 BC B9 C4 10 34 22 13 09 A3 AD F6 A6 4C 2B 9E 3C 36
17	Short	1	15B6	BF 65 63 7E 56 AA 5C 65 D8 E6 51 F2 DB 38 ED CD 15 82 44 20 29 10 DE 35 0D 55 A9 8C 38 40 63 61 DA C6 AE C6 68 A6 93 27 BB F1 80
18	Long	8	3DFB	24 68 68 D4 F1 DE B6 13 DD 24 C3 4D AF A1 DF 6A AA CD 41 1C 0A 51 20 71 5E E7 78 D3 28 7F 91 1D C2 2A 82 57 31 45 37 60 FF 42 E9 B6 A8 36 94 B6 71 EF 19 6A 52 17 B6 C4 F6 AF CB C8 9B CE 1A 7D 63 32 83 0E AA CB 7A 81 9A 9D 0F 8D 0F 8E 81 35 76 F6 CF 70 59 A5 D0 CD 09 34 76 46 15 23 04 C4 37 8F BC 7D 0C C9 BB 13 05 25 C0 72 C1 82 71 E5 CD C7 10 16 79 42 EB 9A 14 3B 89 92 A1 62 DD 9E
19	Short	3		Telegram 4 with 2 bit errors in random position
20	Short	3		Telegram 4 with a 20 bit burst error in random position
21	Short	3		Telegram 4 with 2 pairs of consecutive bit slip/insertions in random position
22	Long	10		Telegram 11 with 2 bit errors in random position
23	Long	10		Telegram 11 with a 50 bit burst error in random position
24	Long	10		Telegram 11 with 2 pairs of consecutive bit slip/insertions in random position

Table 25: Encoded Test Telegrams

A3 Specific Test Telegrams

ID	Description
S1	Valid inverted short-format telegram.
S2	Valid inverted long-format telegram.
S3	Long-format telegram with erroneous control bit b107, which shall be rejected by the Basic Receiver.
S4	Short-format telegram with erroneous bit b108, which shall be rejected by the Basic Receiver.
S5	Inverted long-format telegram with erroneous control bits, which shall be rejected by the Basic Receiver.
S6	Repeated short-format telegram with invalid synch bits, which shall be rejected by the Basic Receiver.
S7	Long-format telegram with invalid word in check bits, which shall be rejected by the Basic Receiver.
S8	Test pattern for short-format extra bits checks, which shall be rejected by the Basic Receiver. The test pattern consists of a repeated short-format telegram, where bits 461..1022, but not bit 922, are inverted. Both bits 0..460 and bits 461..921 constitute error-free telegrams with 120 extra bits.

Table 26: Characteristics of the Specific Test Telegrams

ID	Check sum	Hexadecimal value
S1	1458	21 FD 51 D8 40 6E F3 AC 30 C1 53 B3 8E 91 13 34 E1 12 2C 03 DE 30 9E 10 2F 7F 4B CC FD BF A3 65 64 AB 8E 0F D3 5A 56 33 44 B2 A8
S2	4068	71 C6 74 E5 B5 0C 1C 6C 2A 91 6D 53 74 49 2A AD DB F6 95 18 39 23 30 5D AE 06 26 C3 2F 80 54 D3 EE 88 7E EC AD E6 23 17 DC FD DF 71 09 36 C5 1E F4 4E 7D 23 DF 24 5A D5 50 47 67 CA FC D7 13 F7 AB 6B 1C 58 B8 23 AF B9 D6 84 27 8A E4 9B 86 63 4B 84 83 5F 64 AE 6C 12 48 71 5C D7 41 80 90 6B 82 23 1C 28 FA 9B D7 E8 C0 94 51 D5 F1 30 E0 70 61 5E 6F E6 28 1D F7 CB 73 41 FE 29 61 BB E0 B2
S3	42F1	82 6F BD 12 DA BD 29 45 90 C5 A5 CB 2E 29 80 A7 E1 19 A6 6E 9F 8C D2 D4 0E E8 51 6E 32 65 AB 5D CE F7 AA 3C F5 29 67 36 C4 1F EC 55 C2 6D 50 C2 76 D3 DF 5A 16 D3 50 B2 76 4D C9 F9 47 60 3F A3 BE AC 8D 8B EF 51 A5 5B D7 CB B3 95 4F 2A 11 EC 26 C1 B8 E0 E4 87 1E 6C CE 79 60 E9 CF 95 D5 1C 38 F0 4A D7 51 16 73 7B 46 5F 1B 67 79 5A F0 4E 5B 65 84 1C DC 1A 4E 59 D9 5F 7E 52 F7 E7 B2 8A
S4	11BB	F7 9A E5 2B 6A 68 04 42 2E DC 45 55 93 F8 72 11 7B 36 3B D7 71 97 0B 33 8D 4C D1 1C 24 C0 44 71 04 31 44 D5 68 55 44 36 5B 60 A8
S5	411A	71 C6 74 E5 B5 0C 1C 6C 2A 91 6D 53 74 49 2A AD DB F6 95 18 39 23 30 5D AE 06 26 C3 2F 80 54 D3 EE 88 7E EC AD E6 23 17 DC FD DF 71 09 36 C5 1E F4 4E 7D 23 DF 24 5A D5 50 47 67 CA FC D7 13 F7 AB 6B 1C 58 B8 23 AF B9 D6 84 27 8A E4 9B 86 63 4B 84 83 5F 64 AE 6C 12 48 71 5C D7 41 80 90 6B 82 23 1C 28 FA 9B D7 E8 C0 94 51 D5 F1 30 E0 70 61 5E 5F E6 1B E5 B6 35 43 ED 86 E9 97 84 F5 B8

ID	Check sum	Hexadecimal value
S6	3CA8	F7 9A E5 2B 6A 68 04 42 2E DC 45 55 93 F8 72 11 7B 36 3B D7 71 97 0B 33 8D 4C D1 1C 24 40 45 F5 B3 14 A4 27 0E 8A FF 6D A4 35 EF BC D7 29 5B 53 40 22 11 76 E2 2A AC 9F C3 90 8B D9 B1 DE BB 8C B8 59 9C 6A 66 88 E1 22 02 2F AD 98 A5 21 38 74 57 FB 6D 21 AF 7D E6 B9 4A DA 9A 01 10 8B B7 11 55 64 FE 1C 84 5E CD 8E F5 DC 65 C2 CC E3 53 34 47 09 10 11 7D 6C C5 29 09 C3 A2 BF DB 69 0D 7A
S7	3FD9	8E 39 8B 1A 4A F3 E3 93 D5 6E 92 AC 8B B6 D5 52 24 09 6A E7 C6 DC CF A2 51 F9 D9 3C D0 7F AB 2C 11 77 81 13 52 19 DC E8 23 02 20 8E F6 C9 3A E1 0B B1 82 DC 20 DB A5 2A AF B8 98 35 03 28 EC 08 54 94 E3 A7 47 DC 50 46 29 7B D8 75 1B 64 79 9C B4 7B 7C A0 9B 51 93 ED B7 8E A3 28 BE 7F 6F 94 7D DC E3 D7 05 64 28 17 3F 6B AE 2A 0E CF 1F 8F 9E A1 90 19 C7 4F 6E 71 5B 8A BA E3 37 B7 12 AE
S8	425C	DE 02 AE 27 BF 91 0C 53 CF 3E AC 4C 71 6E EC CB 1E ED D3 FC 21 CF 61 EF D0 80 B4 33 02 40 5C 9A 9B 54 71 F0 2C A5 A9 CC BB 4D 56 F0 15 71 3D FC 88 62 9E 79 F5 62 63 8B 77 61 A7 08 91 60 1E F1 84 F0 81 7B FA 5E 67 ED FD 1B 2B 25 5C 70 7E 9A D2 B1 9A 25 95 48 7F 54 76 10 1B BC EB 0C 30 54 EC E3 A4 44 CD 38 44 8B 00 F7 8C 27 84 0B DF D2 F3 3F 6F C8 D9 59 2A E3 83 F4 D6 95 8C D1 2C AA

Table 27: Encoded Specific Test Telegrams

Annex B (Normative), Air-gap Reference Equipment

B1 General

This Annex establishes the unified test method, and the specification of the specific reference equipment for the tests that have to be done on products in order to establish Interoperability. It also specifies the use of the test equipment as the common reference for Eurobalise. This Annex is needed for Interoperability between different products that are part of the Eurobalise Sub-system.

The specification of the Reference Loops that correspond to the definitions in UNISIG SUBSET-036 is one of the main purposes of this Annex. The Reference Loops are used for absolute level measurements.

For the test, it is also necessary to define a Test Antenna that is activating the Balise during the tests. It shall also be able to receive the signal from the Balise. This Test Antenna is used for relative measurements, and not used for absolute level measurements. All absolute measurements are related to the Reference Loops.

In addition to this, a special Activation Antenna is required for activating the Balise during cross-talk and Up-link tests. This device shall not have a loop for receiving Up-link signals.

In general, this document defines the minimum requirements of the Reference Equipment. Better accuracy is always advantageous, and will reduce necessary margins in the measurement process during Product Qualification.

B2 Reference Loops

B2.1 Size of Reference Loops

The Standard Size and Reduced Size Balises have the below stated Reference Areas for the measurement of field strength from the Antenna Unit to the Balise. These Reference Areas are also valid for the measurement of output field strength from the Balise.

Standard Size (width × length)	= 358 mm × 488 mm
Reduced Size (width × length)	= 200 mm × 390 mm
Reduced Size, Transversal (width × length)	= 390 mm × 200 mm

The Reference Loops shall be made in such a way that the output signal is proportional to the magnetic flux through this Reference Area for the respective loop size of the Reference Area.

The loop shall be protected with an insulating plate. The total thickness of this plate shall be 25 mm to 28 mm, and the physical interface with the environment in the other directions (X and Y) shall be 19 mm to 25 mm outside the Reference Area (i.e., the length and the width of the Reference Loop shall be 38 mm to 50 mm larger than the Reference Area). This plate defines the position and the distance from the Reference Area to where the physical interface with the environment is located. The exact location of this physical interface has to be defined during testing of the debris influence on the flux through the Reference Area and the influence on the output field from the encircling current.

The Reference Loop shall have visible markings that define the reference position for the Reference Loop. It shall be located in the centre of the plate ± 10 mm. This reference position shall be used to indicate the electrical centre of the Reference Loop (i.e., centre of the Reference Area). A positive direction in each of the X, Y, and Z directions relative to the Reference Loop shall be defined.

B2.2 Field Requirements

B2.2.1 Magnetic Field (H-field)

The Reference Loop shall be tested relative to another Reference Loop of the same kind. Tests shall be performed in free air with the two Reference Loops in horizontal orientation, and top side facing each other (i.e., the positive z-direction of each Reference Loop is facing each other). The longest sides shall be parallel, and the X-direction is defined as the direction of the longest side of the loop. The Y-axis is in the horizontal plane and in right angle to the X-axis. The mutual inductance shall be measured between the two Reference Loops, both with the x-axis in parallel and in anti parallel, and the result shall be compared with the theoretically calculated values. The measurements shall be made for the vertical distances (Z), and the lateral (Y) and longitudinal (X) horizontal displacements between the Reference Loops according to the table below.

In the table below, the mutual inductance M is defined in a slightly different form. The attenuation (A) is given in dB according to following formula:

$$A = -20 \cdot \log\left(\frac{\omega \cdot M}{25 \Omega}\right) \quad \text{or inverted:} \quad M = 25 \Omega \cdot \frac{10^{-A/20}}{\omega}$$

The measured mutual impedance expressed in form of A (see above) between two Reference Loops, shall not deviate more than ± 0.5 dB from the following theoretical calculated values. For the Reduced Size Transversal Reference Loops, the values for the Reduced Size Reference Loops are valid. The calculation is made according to the definition of the Reference Areas. Furthermore, the matching transfer ratio B (see sub-clause B2.3 on page 171) and the electrical centre shall be evaluated for each individual Reference Loop.

Table 28 below shows the calculated values for the mutual impedance between two identical Reference Loops.

Height, z [mm]	Lateral, y [mm]	Longitudinal, x [mm]	Standard size, Tele-powering [-dB]	Standard size, Up-link [-dB]	Reduced size, Tele-powering [-dB]	Reduced size, Up-link [-dB]
220	0	0	1.43	17.55	10.85	26.97
220	0	150	3.33	19.45	13.37	29.49
220	0	-150	3.33	19.45	13.37	29.49
220	0	250	6.48	22.60	17.86	33.98
220	0	-250	6.48	22.60	17.86	33.98
220	100	100	3.62	19.74	14.52	30.64
220	100	-100	3.62	19.74	14.52	30.64
220	-100	100	3.62	19.74	14.52	30.64
220	-100	-100	3.62	19.74	14.52	30.64
220	150	200	7.74	23.86	21.22	37.34
220	150	-200	7.74	23.86	21.22	37.34
220	-150	200	7.74	23.86	21.22	37.34
220	-150	-200	7.74	23.86	21.22	37.34
220	150	0	4.35	20.47	16.58	32.70
220	-150	0	4.35	20.47	16.58	32.70
220	200	0	6.63	22.75	21.28	37.40
220	-200	0	6.63	22.75	21.28	37.40
340	0	0	7.48	23.60	18.39	34.51
340	0	275	12.22	28.34	24.71	40.83
340	0	-275	12.22	28.34	24.71	40.83
340	225	225	15.35	31.47	29.90	46.02
340	225	-225	15.35	31.47	29.90	46.02

Height, z [mm]	Lateral, y [mm]	Longitudinal, x [mm]	Standard size, Tele-powering [-dB]	Standard size, Up-link [-dB]	Reduced size, Tele-powering [-dB]	Reduced size, Up-link [-dB]
340	-225	225	15.35	31.47	29.90	46.02
340	-225	-225	15.35	31.47	29.90	46.02
340	275	0	14.48	30.60	29.23	45.35
340	-275	0	14.48	30.60	29.23	45.35
460	0	0	12.63	28.75	24.46	40.58
460	0	250	15.70	31.82	28.34	44.46
460	0	-250	15.70	31.82	28.34	44.46
460	0	350	18.72	34.84	32.11	48.23
460	0	-350	18.72	34.84	32.11	48.23
460	200	200	17.22	33.34	30.56	46.68
460	200	-200	17.22	33.34	30.56	46.68
460	-200	200	17.22	33.34	30.56	46.68
460	-200	-200	17.22	33.34	30.56	46.68
460	300	300	23.04	39.16	37.92	54.04
460	300	-300	23.04	39.16	37.92	54.04
460	-300	300	23.04	39.16	37.92	54.04
460	-300	-300	23.04	39.16	37.92	54.04
460	250	0	16.75	32.87	30.13	46.25
460	-250	0	16.75	32.87	30.13	46.25
460	350	0	20.73	36.85	35.26	51.38
460	-350	0	20.73	36.85	35.26	51.38

Table 28: Mutual Impedance between Reference Loops

B2.2.2 Electric Field (E-field)

The E-field rejection of the Reference Loop shall be more than 25 dB.

25 dB E-field rejection corresponds to 0.5 dB accuracy for a TEM wave (25 dB E-field rejection means that the Reference Loop will give 25 dB lower signal than from an H-field when $E/H=377 \Omega$).

This requirement means that an electrical field of 315 V/m shall generate less signal on the Reference Loop output than a magnetic flux of 10.3 nVs through the Standard Size Reference Loop. In the same way, it means that 445 V/m shall generate less signal on the Reference Loop output than a magnetic flux of 6.5 nVs through the Reduced Size and Transversal Reference Loop.

In the real test situation, the E-field is much less than $377 \Omega \times H$. If the accuracy of the Reference Loop shall comply with the required accuracy, then this must be valid with good margins in the near field zone.

The Reference Loop shall be tested in a pure E-field environment (i.e., negligible magnetic field).

B2.3 Compensation for the Impedance of the Reference Loop

The nominal impedance for the equipment connected to the Reference Loop shall be 50 Ω (i.e., the source impedance of the generator and the load impedance of the power meter shall be 50 Ω when connected to the Reference Loops).

The Reference Loop should be connected to a 50 Ω load when it is used for Tele-powering flux measurements. Then the voltage V_m shall be measured over this 50 Ω resistance. If the Reference Loop has a serial impedance (the shunting impedance must be negligible) of Z_d for the actual frequency, and if the Reference Loop has the matching transfer ratio of B, then the flux through the reference area can be calculated according to:

$$\Phi_d = \frac{V_m \cdot B}{\omega} \left(1 + \frac{Z_d}{50} \right)$$

If the Reference Loop is fed with a voltage source with the voltage $2 \times V_s$ and with the serial resistance of 50 Ω , then the current encircling the reference area can be calculated according to:

$$I_U = \frac{2 \cdot V_s \cdot B}{50 \cdot \left(1 + \frac{Z_u}{50} \right)}$$

where Z_u is the serial impedance of the Reference Loop.

The impedance of the Reference Loop may be influenced by the test object, or by the environment. In this case the measurement result must be compensated (if the compensation is not negligible) with respect to the actual impedance during the test (i.e., the impedance must then be measured). This has to be performed for each individual set up with the Reference Loop.

Another possibility is to directly measure the actual current into the Reference Loop, utilising a special Balun with current sense capabilities, and to measure the output voltage from the Reference Loop with a “high impedance” device (i.e., the impedance of the Reference Loop shall be negligible compared to the measuring device). However, please observe that the B-factor must be considered also in this case (e.g., in order to obtain a current of I_{ux} encircling the reference area, the current measured by such a current sense balun shall be I_{ux}/B)

If the shunting impedance is not negligible, the designer of the Reference Loop must give and verify the formula for how the influence of this shall be compensated.

The B-factor is a matching transfer ratio that provides a compensation of a specific design solution so that the characteristics of Table 28 on page 170 are obtained. In general, this considers compensation if the electrical size of a specific solution is not exactly equal to the defined reference area (but still is within the acceptable tolerances for the Reference Loop), and compensation for other imperfections (such as stray capacitance etc.).

B2.4 Frequency Characteristics of the Reference Field

Up-link: When the Reference Loop is supplied with a sinusoidal signal from a constant and perfect 50 Ω source, then the amplitude of the Magnetic Field (H-field) shall be within +0 dB and -0.5 dB over the frequency band 3.89 MHz to 4.59 MHz. The requirement is applicable under free air conditions anywhere within the Main Lobe Zone defined by UNISIG SUBSET-036.

When the Reference Loop is supplied with a sinusoidal signal from a constant and perfect 50 Ω source, then the amplitude of the Magnetic Field (H-field) shall be within +0 dB and -1.0 dB over the frequency band 3.5 MHz to 5.0 MHz. The requirement is applicable under free air conditions anywhere within the Main Lobe Zone defined by UNISIG SUBSET-036.

When the Reference Loop is supplied with a sinusoidal signal from a constant and perfect 50 Ω source, then the variation of the group delay shall not be more than 35 ns over the frequency band 3.5 MHz to 5.0 MHz. The requirement is applicable under free air conditions anywhere within the Main Lobe Zone defined by UNISIG SUBSET-036.

Tele-powering: When a homogeneous and constant Magnetic Flux (ϕ) is passing through the Reference Loop, then the output voltage shall be as follows for the frequency range 27.095 MHz -10 kHz to 27.095 MHz $+10$ kHz:

- | | |
|---|--|
| • With a perfect 50 Ω load | Output Voltage variation max. ± 0.2 dB |
| • For resistive loads within the Load Range 20 Ω to 200 Ω | Output Voltage variation max. ± 0.5 dB |
| • For complex loads within the Load Range 20 Ω to 200 Ω | Output Voltage variation max. ± 1.0 dB ²⁷ |

The requirement is applicable under free air conditions anywhere within the Main Lobe Zone defined by UNISIG SUBSET-036.

B2.5 Influence of Debris

B2.5.1 The flux through the Reference Area

When performing tests during influence of the various conditions defined by sub-clause B5 on page 190, the impedance of the Reference Loop will be changed. After having performed compensation for this change of impedance, the accuracy of the measured induced voltage shall not be degraded more than 1 dB.

B2.5.2 The field from the Balise

When performing tests during influence of the various conditions defined by sub-clause B5 on page 190, the impedance of the Reference Loop will be changed. After having performed compensation for this change of impedance, the accuracy of the measured current shall not be degraded more than 1 dB.

²⁷ It shall be possible to achieve better accuracy if special precautions are taken (e.g., by measuring the frequency and taking the actual Reference Loop impedance into account).

B2.6 Conformity Testing of Reference Loops

B2.6.1 Test Procedure

The theoretically calculated mutual inductance between two identical Reference Loops for a number of positions is defined in sub-clause B2.2.1 on page 169, and shall be compared to measured values in order to determine the measurement accuracy of the Reference Loops. The following Test Procedure should be used:

For each position described in B2.2.1 on page 169, the following procedure should be performed for the Reference Loops.

1. Measure the Up-link and Tele-powering attenuation between the two Reference Loops of the same kind.
2. Measure the impedance of the Reference Loop that transmits the 27.095 MHz and 4.23 MHz signals respectively.
3. Calculate the compensation factor for the impedance in the Reference Loop, and add this compensation factor to the measured attenuation. The compensation shall be based on the actual impedance of the transmitting Reference Loop (for each individual test point), and free air impedance of the receiving Reference Loop.
4. Compare this compensated result with the theoretically calculated value.
5. Rotate one of the Reference Loops 180° in the X-Y plane, and repeat steps 1 through 4. This step evaluates potential systematic asymmetry of the Reference Loops.

B2.6.2 Measurement set-up

A proposed test set-up is shown in Figure 51 below.²⁸ Clause F1 of Annex F on page 297 gives an example of suitable test equipment.

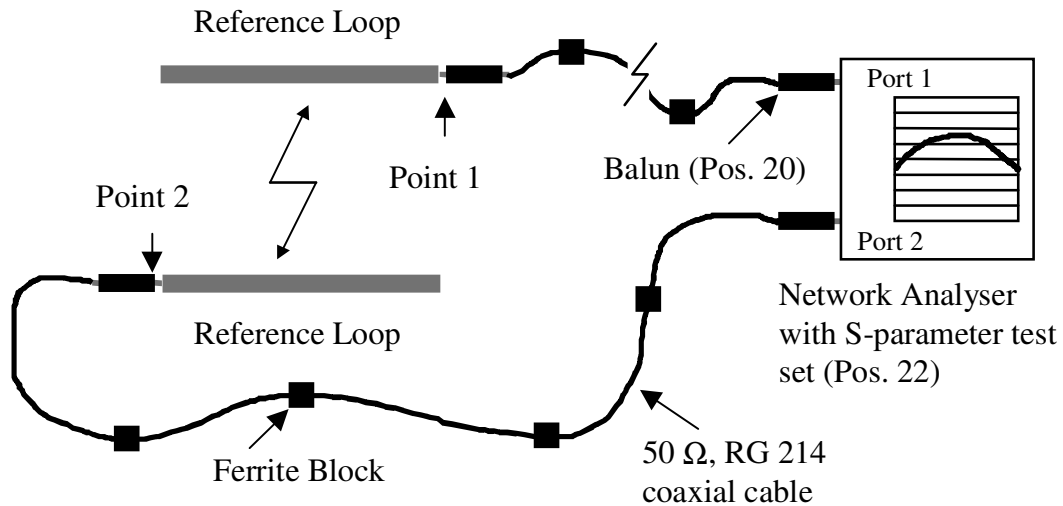

Figure 51: Measurement set-up

²⁸ The Reference Loops shall be placed on a non-disturbing positioning system, and connected to the network analyser with a 50 Ω coaxial cable with ferrite devices. The cables shall be separated through placing the Reference Loops so that the cables will not be parallel to each other. The positioning system should have an accuracy in displacement in the X, Y, and Z directions of about 1 mm. It is essential that the positioning system does not disturb the field distribution. Ferrite devices shall be used in order to reduce the RF field effect on the measurements. The Baluns shall be placed at the end of the cables, i.e., at the Reference Loop and the network analyser connector. The ferrite blocks shall be placed regularly along the cables evenly spaced at approximately every 70 cm. The core material in the Ferrite Blocks shall be "Amidon 43" or equivalent. It is essential that the cables are of double screened type (e.g., RG 214 coaxial cable).

B2.6.3 Instrument set-up and Calibration

A network analyser with S-parameter test set should be used to measure the attenuation between the Reference Loops, and also the impedance of one Reference Loop for the different positions.

The following instrument set-ups and calibrations should be used:

- Transmission measurements:

Centre frequency:	Up-link - 4.23 MHz, Tele-powering - 27.095 MHz
Frequency span:	2 MHz
Trace 1 input:	S21 (Transmission, Port 1 - Port 2)
Display function:	Log/Mag
Marker:	Up-link - 4.23 MHz, Tele-powering - 27.095 MHz

The measurement shall be normalised with points 1 and 2 in Figure 51 connected together.

- Impedance measurements:

Centre frequency:	Up-link - 4.23 MHz, Tele-powering - 27.095 MHz
Frequency span:	2 MHz
Trace 2 input:	S11 (Reflection, Port 1)
Display function:	Smith Chart
Marker:	Up-link - 4.23 MHz, Tele-powering - 27.095 MHz

A “full one port calibration” shall be performed at port 1 at the end of the cable, i.e., at point 1 defined in Figure 51.

B2.6.4 Compensation for the impedance of the Reference Loop

The measured values of the Reference Loop impedance and the attenuation between the two Reference Loops shall be recorded. The compensation factor for the mutual inductance between the Reference Loops is calculated from the measured impedance according to the following equation:

$$20 * \text{LOG} \left[\frac{\sqrt{(50 + \text{re})^2 + \text{im}^2}}{50} \right]$$

where re = Real part of the Reference Loop impedance.

im = Imaginary part of the Reference Loop impedance.

The transmitting Reference Loop shall be compensated according to the equation above, considering the actual impedance of each individual test point. The receiving Reference Loop shall be compensated based on the impedance during free air conditions.

The compensated value of the attenuation between the two Reference Loops is calculated by adding the compensation factor to the measured attenuation between the two Reference Loops. Compare the measured value with the theoretically calculated.

The model of Figure 52 below is assumed as the basis for the process:

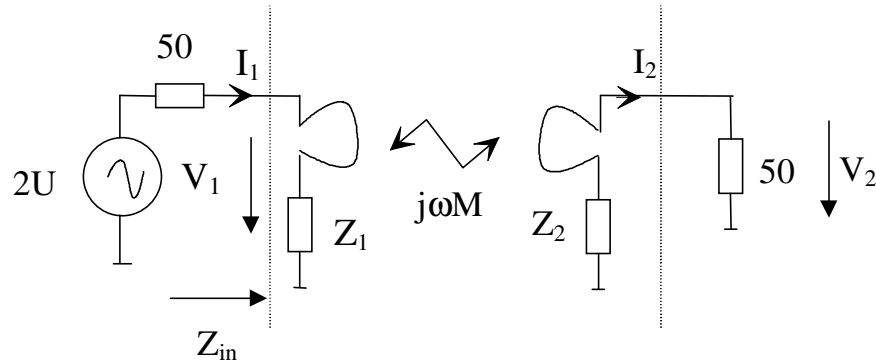

Figure 52: Equivalent circuit diagram

Measure Z_2 during free air conditions (i.e., long distance between the two Reference Loops), and Z_{in} for each individual test position. The following equations apply:

- 1) $V_1 = I_1 Z_1 - j\omega M I_2$
- 2) $V_2 = -I_2 Z_2 + j\omega M I_1$
- 3) $P_f = \frac{U^2}{50}$
- 4) $I_2 = \frac{V_2}{50} \Rightarrow V_2 = 50 I_2$
- 5) $Z_{in} = \frac{V_1}{I_1} \Rightarrow \{1\} \Rightarrow Z_{in} = Z_1 - j\omega M \frac{I_2}{I_1}$
- 6) $\{4 \text{ and } 2\} \Rightarrow I_2 = \frac{j\omega M I_1}{50 + Z_2}$
- 7) $\{5 \text{ and } 6\} \Rightarrow Z_{in} = Z_1 + \frac{\omega^2 M^2}{50 + Z_2}$ N.B. Dependent on M !
- 8) $I_1 = \frac{2U}{50 + Z_{in}} \Rightarrow \{3\} \Rightarrow I_1 = \frac{2\sqrt{50P_f}}{50 + Z_{in}}$
- 9) $\{2\} \Rightarrow j\omega M = \frac{V_2 + I_2 Z_2}{I_1} \Rightarrow \{4 \text{ and } 8\} \Rightarrow j\omega M = \frac{V_2 \left(1 + \frac{Z_2}{50}\right)}{2\sqrt{50P_f}} (50 + Z_{in})$
- 10) $\{9\} \Rightarrow j\omega M = \frac{50V_2 \left(1 + \frac{Z_2}{50}\right) \left(1 + \frac{Z_{in}}{50}\right)}{2\sqrt{50P_f}}$
- 11) $\therefore j\omega M = \frac{50V_2 k}{2\sqrt{50P_f}}$ where $k = \left(1 + \frac{Z_2}{50}\right) \left(1 + \frac{Z_{in}}{50}\right)$

B2.6.5 Test Environment

The test should be performed in a laboratory environment where no other H-field exists except the ones that are to be measured. The Reference Loops shall be separated more than 0.5 m from any metallic object during the measurements.

B2.6.6 Calculation of correction factors

Three Reference Loops of the same kind should be crosswise tested against each other in accordance with the Test Procedure described in sub-clause B2.6.1 on page 173. Thereafter, the differences between the measured and the theoretical values should be allocated to each individual Reference Loop. This shall be performed applying the following equation system to the measured values:

$$\begin{aligned}\varepsilon_1 &= \frac{a_{12} + a_{13} - a_{23} - a_0}{2} \\ \varepsilon_2 &= \frac{a_{12} + a_{23} - a_{13} - a_0}{2} \\ \varepsilon_3 &= \frac{a_{13} + a_{23} - a_{12} - a_0}{2}\end{aligned}$$

where: a_{12} = measured attenuation between Reference Loop 1 and Reference Loop 2
 a_{13} = measured attenuation between Reference Loop 1 and Reference Loop 3
 a_{23} = measured attenuation between Reference Loop 2 and Reference Loop 3
 a_0 = theoretical attenuation between two Reference Loops
 ε_1 = error of Reference Loop 1
 ε_2 = error of Reference Loop 2
 ε_3 = error of Reference Loop 3

An alternative is to make a measurement between two Reference Loops only, where one of these is an already characterised device, and the other is the device to be calibrated.

Finally an attempt should be performed in order to minimise the mean value and the standard deviation of the calculated errors for each individual Reference Loop.

The method for doing this is to simulate a (small) movement of the electrical centre point (in X, Y, and Z) of the Reference Loop, add the corresponding compensation factors to the measured values, and to evaluate the compensated results. The compensation factors shall be calculated from the derivatives of the field distribution (in dB/cm) for each individual test point. The matching transfer ratio ('B') of the Reference Loop (that is nominally 1.00) may also be changed. The method for this is introducing a compensation factor that is added to the measured values, and that minimises the overall mean value of the errors. In this case, the compensation factor is identical for all geometrical positions (for one specific Reference Loop), and constitutes a change of the 'B' factor defined in sub-clause B2.3 on page 171. The derivatives of the field distribution are found in the Table 29 below. In order to evaluate potential systematic asymmetry, one of the Reference Loops should be rotated 180° in the X-Y plane and the results should be taken into consideration.

Applications suitable for performing the process are embedded in sub-clause B2.7 on page 180.

Height z [mm]	Lateral y [mm]	Longitudinal x [mm]	Standard Size, x-derivative [dB/cm]	Standard Size, y-derivative [dB/cm]	Standard Size, z-derivative [dB/cm]	Reduced Size, x-derivative [dB/cm]	Reduced Size, y-derivative [dB/cm]	Reduced Size, z-derivative [dB/cm]
220	0	0	0	0	0.55	0	0	0.70
220	0	150	0.25	0	0.49	0.34	0	0.63
220	0	-150	0.25	0	0.49	0.34	0	0.63
220	0	250	0.40	0	0.44	0.60	0	0.53
220	0	-250	0.40	0	0.44	0.60	0	0.53
220	100	100	0.18	0.27	0.47	0.24	0.54	0.54
220	100	-100	0.18	0.27	0.47	0.24	0.54	0.54
220	-100	100	0.18	0.27	0.47	0.24	0.54	0.54
220	-100	-100	0.18	0.27	0.47	0.24	0.54	0.54
220	150	200	0.33	0.42	0.36	0.48	0.86	0.26
220	150	-200	0.33	0.42	0.36	0.48	0.86	0.26
220	-150	200	0.33	0.42	0.36	0.48	0.86	0.26
220	-150	-200	0.33	0.42	0.36	0.48	0.86	0.26
220	150	0	0	0.40	0.45	0	0.81	0.41
220	-150	0	0	0.40	0.45	0	0.81	0.41
220	200	0	0	0.56	0.38	0	1.14	0.12
220	-200	0	0	0.56	0.38	0	1.14	0.12
340	0	0	0	0	0.46	0	0	0.55
340	0	275	0.36	0	0.36	0.48	0	0.40
340	0	-275	0.36	0	0.36	0.48	0	0.40
340	225	225	0.30	0.44	0.25	0.39	0.66	0.13
340	225	-225	0.30	0.44	0.25	0.39	0.66	0.13
340	-225	225	0.30	0.44	0.25	0.39	0.66	0.13
340	-225	-225	0.30	0.44	0.25	0.39	0.66	0.13
340	275	0	0	0.54	0.25	0	0.79	0.09
340	-275	0	0	0.54	0.25	0	0.79	0.09
460	0	0	0	0	0.40	0	0	0.45
460	0	250	0.25	0	0.34	0.32	0	0.36
460	0	-250	0.25	0	0.34	0.32	0	0.36
460	0	350	0.36	0	0.27	0.45	0	0.27
460	0	-350	0.36	0	0.27	0.45	0	0.27
460	200	200	0.20	0.27	0.29	0.25	0.36	0.28
460	200	-200	0.20	0.27	0.29	0.25	0.36	0.28
460	-200	200	0.20	0.27	0.29	0.25	0.36	0.28
460	-200	-200	0.20	0.27	0.29	0.25	0.36	0.28
460	300	300	0.31	0.41	0.14	0.38	0.52	0.04
460	300	-300	0.31	0.41	0.14	0.38	0.52	0.04
460	-300	300	0.31	0.41	0.14	0.38	0.52	0.04
460	-300	-300	0.31	0.41	0.14	0.38	0.52	0.04
460	250	0	0	0.34	0.29	0	0.44	0.27
460	-250	0	0	0.34	0.29	0	0.44	0.27
460	350	0	0	0.47	0.18	0	0.59	0.09
460	-350	0	0	0.47	0.18	0	0.59	0.09

Table 29: Derivatives of the field distribution

B2.6.7 Labelling and Marking of Reference Loops

In the event that the electrical centre point evaluated as defined by B2.6.6 is different from the geometrical centre point, then the electrical centre point shall be clearly marked on the Reference Loop. The geometrical centre point is already marked during the manufacturing process of the Reference Loop.

Each individual Reference Loop should be equipped with a label where the following information is defined:

- Type of Reference Loop (Standard or Reduced Size)
- Part Number
- Serial Number
- Revision Status
- Impedance in free air
- B-factor

B2.7 Application for Reference Loop Calibration

B2.7.1 General

The herein included embedded objects constitute Excel applications that are to be used for the purpose of evaluating the calibration of the Reference Loops, and determining the applicable B-factors and (if necessary) positioning correction parameters.

Instructions for use of the applications are included in the Excel charts.

For informative purposes, the hereafter following sub-clause B2.7.2 and sub-clause B2.7.3 include bitmap pictures of the charts of the embedded objects.

Please observe that that both the bitmaps and the embedded objects are filled with fictitious data (included in the yellow cells).



Example_Std_Ref_Loop_Calibration.xls



Example_Red_Ref_Loop_Calibration.xls

B2.7.2 Standard Size Reference Loop

Tested units in this sheet			Free air impedance (Z _a)			
Standard size Reference Loops			Tele-powering		Up-link	
Number	Rev.	S/N	re [Ohm]	in [Ohm]	re [Ohm]	in [Ohm]
1	RTA	SK1	3.1	0.3	0.7	1.3
2	RTA	SK2	3.2	0.7	0.8	0.7
3	RTA	SK3	3.1	1.6	0.7	1.0

Differences in x, y, and z positions indicate how far from the Reference Mark the Electrical Centre is located.

B factors indicate the actual Matching Transfer Ratio of the device.

Please observe also 'definitions' and 'Instructions' further down.

* The letters in the parentheses defines which measurement series the data is taken in the column.

* 0 deg means that the reference loops are in parallel to each other, i.e. the connectors are at the same direction for both ref. loops.

* 180 deg means that the reference loops are in anti-parallel to each other, i.e. the connectors are in the opposite direction for the both ref. loops.

Ref. Loop 1 & 2, 0 deg			Calculated attenuation		Derivatives			Measured attenuation		Transmitting reference loop impedance (Z ₀)					Compensation factor		Compensated attenuation		Difference measured-calculated		Pos. and Match. Correction		Difference measured-corrected					
Height, [mm]	Lateral [mm]	Long. [mm]	Tele-powering, [dB]	Up-link, [dB]	z deviation [dB/cm]	y deviation [dB/cm]	x deviation [dB/cm]	(b) Tele-powering, [dB]	(a) Up-link, [dB]	(b) Tele-powering resistance	(b) Tele-powering reactance	(a) Up-link resistance	(a) Up-link reactance	Up-link, [dB]	Tele-powering, [dB]	Tele-powering, [dB]	Up-link, [dB]	Tele-powering, [dB]	Up-link, [dB]	Tele-powering, [dB]	Tele-powering, [dB]	Up-link, [dB]	Tele-powering, [dB]	Tele-powering, [dB]	Up-link, [dB]	Tele-powering, [dB]		
220	-200	0	-6.63	-22.75	0.00	0.56	0.38	-8.40	-24.00	5.70	0.30	0.60	1.20	0.28	1.48	-6.92	-23.72	-0.29	-0.97	0.28	1.15	-0.01	0.18					
220	-150	0	-4.35	-20.47	0.00	0.40	0.45	-6.30	-21.70	7.60	0.50	0.80	1.20	0.28	1.77	-4.53	-21.42	-0.18	-0.95	0.28	1.15	0.10	0.20					
220	-150	200	-7.74	-23.86	0.33	0.42	0.36	-9.30	-25.10	5.10	0.30	0.80	1.20	0.28	1.38	-7.92	-24.82	-0.18	-0.96	0.28	1.15	0.10	0.19					
220	-150	-200	-7.74	-23.86	0.33	0.42	0.36	-9.30	-25.20	5.10	0.30	0.80	1.20	0.28	1.38	-8.02	-24.92	-0.28	-1.06	0.28	1.15	0.00	0.08					
220	-100	-100	-3.82	-19.74	0.18	0.27	0.47	-5.70	-20.90	8.40	0.50	0.90	1.20	0.30	1.89	-3.81	-20.60	-0.19	-0.86	0.28	1.15	0.09	0.28					
220	-100	100	-3.82	-19.74	0.18	0.27	0.47	-5.60	-20.90	8.40	0.50	0.90	1.20	0.30	1.89	-3.71	-20.60	-0.09	-0.86	0.28	1.15	0.19	0.29					
220	0	250	-6.48	-22.60	0.40	0.00	0.44	-8.20	-23.80	5.80	0.30	0.80	1.20	0.28	1.49	-6.71	-23.52	-0.23	-0.92	0.28	1.15	0.05	0.23					
220	0	150	-3.33	-19.45	0.25	0.00	0.49	-5.40	-20.60	8.80	0.60	0.90	1.20	0.30	1.95	-3.45	-20.30	-0.12	-0.85	0.28	1.15	0.16	0.30					
220	0	0	-1.43	-17.25	0.00	0.00	0.55	-3.90	-18.60	12.00	0.80	0.90	1.20	0.30	2.41	-1.49	-18.30	-0.06	-0.75	0.28	1.15	0.22	0.40					
220	0	-150	-3.33	-19.45	0.25	0.00	0.49	-5.40	-20.60	8.70	0.60	0.90	1.20	0.30	1.93	-3.47	-20.30	-0.14	-0.85	0.28	1.15	0.14	0.30					
220	0	-250	-6.48	-22.60	0.40	0.00	0.44	-8.20	-23.90	5.70	0.30	0.80	1.20	0.28	1.48	-6.72	-23.62	-0.24	-1.02	0.28	1.15	0.04	0.13					
220	100	-100	-3.82	-19.74	0.18	0.27	0.47	-5.60	-20.90	8.40	0.50	0.90	1.20	0.30	1.89	-3.71	-20.60	-0.09	-0.86	0.28	1.15	0.19	0.29					
220	100	100	-3.82	-19.74	0.18	0.27	0.47	-5.60	-20.90	8.40	0.50	0.90	1.20	0.30	1.89	-3.71	-20.60	-0.09	-0.86	0.28	1.15	0.19	0.29					
220	150	200	-7.74	-23.86	0.33	0.42	0.36	-9.30	-25.00	5.10	0.20	0.80	1.20	0.28	1.38	-7.92	-24.72	-0.18	-0.96	0.28	1.15	0.10	0.20					
220	150	-200	-7.74	-23.86	0.33	0.42	0.36	-9.30	-25.10	5.10	0.20	0.80	1.20	0.28	1.38	-7.92	-24.82	-0.18	-0.96	0.28	1.15	0.10	0.19					
220	200	0	-4.35	-20.47	0.00	0.40	0.45	-6.20	-21.60	7.60	0.40	0.80	1.20	0.28	1.77	-4.43	-21.32	-0.09	-0.85	0.28	1.15	0.20	0.30					
220	250	0	-6.63	-22.75	0.00	0.56	0.38	-8.30	-23.90	5.70	0.20	0.60	1.20	0.28	1.48	-6.82	-23.62	-0.19	-0.87	0.28	1.15	0.09	0.28					
340	275	0	-14.48	-30.60	0.00	0.54	0.25	-15.90	-32.00	3.40	0.20	0.70	1.20	0.26	1.11	-14.79	-31.74	-0.31	-1.14	0.28	1.15	-0.03	0.01					
340	225	225	-15.35	-31.47	0.30	0.44	0.25	-16.80	-33.00	3.40	0.20	0.80	1.20	0.28	1.11	-15.69	-32.72	-0.34	-1.25	0.28	1.15	-0.06	-0.10					
340	225	-225	-15.35	-31.47	0.30	0.44	0.25	-16.80	-33.00	3.40	0.20	0.80	1.20	0.28	1.11	-15.69	-32.72	-0.34	-1.25	0.28	1.15	-0.06	-0.10					
340	0	-275	-12.22	-28.34	0.36	0.00	0.36	-13.70	-29.80	3.70	0.30	0.80	1.20	0.28	1.16	-12.54	-29.52	-0.32	-1.18	0.28	1.15	-0.04	-0.03					
340	0	0	-7.48	-23.60	0.00	0.00	0.48	-9.00	-24.80	5.20	0.40	0.80	1.20	0.28	1.40	-7.60	-24.52	-0.12	-0.92	0.28	1.15	0.16	0.23					
340	0	275	-12.22	-28.34	0.36	0.00	0.36	-13.70	-29.70	3.70	0.20	0.80	1.20	0.28	1.16	-12.54	-29.42	-0.32	-1.08	0.28	1.15	-0.04	-0.07					
340	-225	225	-15.35	-31.47	0.30	0.44	0.25	-16.80	-33.00	3.40	0.20	0.80	1.20	0.28	1.11	-15.69	-32.72	-0.34	-1.25	0.28	1.15	-0.06	-0.10					
340	-225	-225	-15.35	-31.47	0.30	0.44	0.25	-16.80	-33.00	3.40	0.20	0.80	1.20	0.28	1.11	-15.69	-32.72	-0.34	-1.25	0.28	1.15	-0.06	-0.10					
340	-275	0	-14.48	-30.60	0.00	0.54	0.25	-15.90	-32.10	3.50	0.20	0.60	1.20	0.26	1.13	-14.77	-31.82	-0.29	-1.22	0.28	1.15	-0.01	-0.04					
450	-350	0	-20.73	-36.85	0.00	0.47	0.18	-22.20	-38.60	3.10	0.20	0.70	1.20	0.26	1.06	-21.14	-38.34	-0.41	-1.49	0.28	1.15	-0.11	-0.37					
450	-300	300	-23.04	-39.16	0.31	0.41	0.14	-24.60	-41.10	3.10	0.20	0.70	1.20	0.26	1.06	-23.54	-40.84	-0.50	-1.68	0.28	1.15	-0.22	-0.53					
450	-300	-300	-23.04	-39.16	0.31	0.41	0.14	-24.70	-41.20	3.10	0.20	0.70	1.20	0.26	1.06	-23.64	-40.94	-0.60	-1.78	0.28	1.15	-0.32	-0.63					
450	-250	0	-16.75	-32.87	0.00	0.34	0.29	-18.20	-34.40	3.30	0.20	0.80	1.20	0.28	1.09	-17.11	-34.12	-0.36	-1.25	0.28	1.15	-0.08	-0.10					
450	-200	200	-17.22	-33.34	0.20	0.27	0.29	-19.60	-34.90	3.30	0.20	0.70	1.20	0.26	1.09	-17.51	-34.64	-0.29	-1.30	0.28	1.15	-0.01	-0.15					
450	-200	-200	-17.22	-33.34	0.20	0.27	0.29	-18.70	-34.90	3.30	0.20	0.70	1.20	0.26	1.09	-17.61	-34.64	-0.39	-1.30	0.28	1.15	-0.11	-0.15					
450	0	-350	-18.72	-34.84	0.36	0.00	0.27	-20.30	-36.60	3.20	0.20	0.70	1.20	0.26	1.08	-19.22	-36.34	-0.50	-1.50	0.28	1.15	-0.22	-0.35					
450	0	-250	-15.70	-31.82	0.25	0.00	0.34	-17.20	-33.30	3.30	0.20	0.70	1.20	0.26	1.09	-16.11	-33.04	-0.41	-1.22	0.28	1.15	-0.11	-0.07					
450	0	0	-12.83	-28.75	0.00	0.00	0.40	-14.00	-30.10	3.70	0.30	0.80	1.20	0.28	1.18	-12.84	-29.82	-0.21	-1.07	0.28	1.15	0.07	0.08					
450	0	250	-15.70	-31.82	0.25	0.00	0.34	-17.10	-33.30	3.30	0.20	0.70	1.20	0.26	1.09	-16.01	-33.04	-0.31	-1.22	0.28	1.15	-0.03	-0.07					
450	0	350	-18.72	-34.84	0.36	0.00	0.27	-20.20	-36.50	3.20	0.20	0.80	1.20	0.28	1.08	-19.12	-36.22	-0.40	-1.38	0.28	1.15	-0.12	-0.23					
450	200	200	-17.22	-33.34	0.20	0.27	0.29	-18.70	-34.90	3.20	0.20	0.80	1.20	0.28	1.08	-17.62	-34.62	-0.40	-1.28	0.28	1.15	-0.12	-0.13					
450	200	-200	-17.22	-33.34	0.20	0.27	0.29	-18.70	-34.90	3.30	0.20	0.70	1.20	0.26	1.09	-17.61	-34.64	-0.39	-1.30	0.28	1.15	-0.11	-0.15					
450	250	0	-16.75	-32.87	0.00	0.34	0.29	-18.10	-34.40	3.30	0.20	0.80	1.20	0.28	1.09	-17.01	-34.12	-0.26	-1.25	0.28	1.15	0.02	-0.10					
450	300	300	-23.04	-39.16	0.31	0.41	0.14	-24.60	-41.20	3.10	0.20	0.70	1.20	0.26	1.06	-23.74	-40.94	-0.70	-1.78	0.28	1.15	-0.42	-0.63					
450	300	-300	-23.04	-39.16	0.31	0.41	0.14	-24.70	-41.20	3.10	0.20	0.60	1.20	0.26	1.06	-23.64	-40.92	-0.60	-1.78	0.28	1.15	-0.32	-0.61					
450	350	0	-20.73	-36.85	0.00	0.47	0.18	-22.30	-38.60	3.10	0.20	0.70	1.20	0.26	1.06	-21.24	-38.34	-0.51	-1.49	0.28	1.15	-0.23	-0.34					
Difference in x-position [cm]			0.00														Std. dev:		0.15		0.28		0.15		0.28			
Difference in y-position [cm]			0.00																Max:		-0.06		-0.75		0.22		0.40	
Difference in z-position [cm]			0.00																Min:		-0.70		-1.78		-0.42		-0.63	
B factor, up-link			0.88																Max Min:		0.64		1.02		0.64		1.02	
B factor, tele-powering			0.97																Average:		-0.30		-1.16		-0.02		-0.01	

Ref. Loop 1 & 2, 180 deg			Calculated	Derivatives			Measured		Transmitting reference loop impedance (Z _u)				Compensation		Compensated		Difference		Pos. and Mch.		Difference		
Positioning parameters			attenuation	z			attenuation		Reference loop number 1				factor		attenuation		measured-calculated		Correction		measured-corrected		
Height, z [mm]	Lateral y [mm]	Long. x [mm]	Tele-powering, [dB]	Up-link, [dB]	z deviation [dB/cm]	y deviation [dB/cm]	x deviation [dB/cm]	(T) Tele-powering, [dB]	(U) Up-link, [dB]	(T) Tele-powering resistance, [dB]	(U) Tele-powering resistance, [dB]	(U) Up-link resistance, [dB]	(U) Up-link reactance, [dB]	Up-link, [dB]	Tele-powering, [dB]	Tele-powering, [dB]	Up-link, [dB]	Tele-powering, [dB]	Up-link, [dB]	Tele-powering, [dB]	Up-link, [dB]	Tele-powering, [dB]	Up-link, [dB]
220	-200	0	-8.63	-22.75	0.00	0.56	0.38	-8.30	-23.80	5.70	0.40	0.80	1.20	0.28	1.48	-8.82	-23.82	-1.19	-0.87	0.28	1.15	0.09	0.28
220	-150	0	-4.35	-20.47	0.00	0.40	0.45	-6.20	-21.60	7.60	0.50	0.80	1.20	0.28	1.77	-4.43	-21.32	-0.98	-0.85	0.28	1.15	0.20	0.30
220	-150	200	-7.74	-23.86	0.33	0.42	0.36	-9.30	-25.10	5.10	0.30	0.80	1.20	0.28	1.38	-7.92	-24.82	-1.18	-0.96	0.28	1.15	0.10	0.19
220	-150	-200	-7.74	-23.86	0.33	0.42	0.36	-9.30	-25.10	5.10	0.30	0.80	1.20	0.28	1.38	-7.92	-24.72	-1.08	-0.86	0.28	1.15	0.20	0.29
220	-100	-100	-3.62	-19.74	0.18	0.27	0.47	-5.60	-20.80	8.40	0.50	0.80	1.20	0.30	1.89	-3.71	-20.60	-0.99	-0.86	0.28	1.15	0.19	0.29
220	0	250	-6.48	-22.60	0.40	0.00	0.44	-8.20	-23.90	6.70	0.30	0.80	1.20	0.28	1.48	-6.72	-23.62	-1.04	-1.02	0.28	1.15	0.04	0.13
220	0	150	-3.33	-19.45	0.25	0.00	0.49	-5.40	-20.60	8.70	0.60	0.80	1.20	0.30	1.93	-3.47	-20.30	-1.14	-0.85	0.28	1.15	0.14	0.30
220	0	0	-1.43	-17.55	0.00	0.00	0.55	-3.90	-18.60	12.00	0.80	0.80	1.20	0.30	2.41	-1.49	-18.30	-1.06	-0.75	0.28	1.15	0.22	0.40
220	0	-150	-3.33	-19.45	0.25	0.00	0.49	-5.30	-20.60	8.80	0.60	0.80	1.20	0.30	1.95	-3.35	-20.30	-1.02	-0.85	0.28	1.15	0.28	0.38
220	0	-250	-6.48	-22.60	0.40	0.00	0.44	-8.10	-23.90	5.80	0.30	0.80	1.20	0.28	1.48	-8.61	-23.52	-1.13	-0.92	0.28	1.15	0.15	0.23
220	100	-100	-3.62	-19.74	0.18	0.27	0.47	-5.60	-20.80	8.40	0.50	0.80	1.20	0.30	1.89	-3.71	-20.60	-0.99	-0.86	0.28	1.15	0.19	0.29
220	100	100	-3.62	-19.74	0.18	0.27	0.47	-5.60	-20.80	8.40	0.50	0.80	1.20	0.30	1.89	-3.71	-20.60	-0.99	-0.86	0.28	1.15	0.19	0.29
220	150	200	-7.74	-23.86	0.33	0.42	0.36	-9.40	-25.20	5.10	0.20	0.80	1.20	0.28	1.38	-8.02	-24.92	-1.28	-1.06	0.28	1.15	0.00	0.09
220	150	-200	-7.74	-23.86	0.33	0.42	0.36	-9.30	-25.10	5.10	0.20	0.80	1.20	0.28	1.38	-7.92	-24.82	-1.18	-0.96	0.28	1.15	0.10	0.19
220	200	0	-4.35	-20.47	0.00	0.40	0.45	-6.20	-21.60	7.60	0.40	0.80	1.20	0.28	1.77	-4.43	-21.32	-0.98	-0.85	0.28	1.15	0.20	0.30
220	200	0	-8.63	-22.75	0.00	0.56	0.38	-8.30	-23.80	5.70	0.30	0.80	1.20	0.28	1.48	-8.82	-23.72	-1.19	-0.97	0.28	1.15	0.09	0.18
340	275	0	-14.48	-30.60	0.00	0.54	0.25	-15.90	-32.10	3.50	0.20	0.80	1.20	0.28	1.13	-14.77	-31.82	-0.29	-1.22	0.28	1.15	-0.01	-0.07
340	225	225	-15.35	-31.47	0.30	0.44	0.25	-16.80	-33.10	3.40	0.20	0.80	1.20	0.28	1.11	-15.79	-32.82	-0.44	-1.35	0.28	1.15	-0.16	-0.20
340	225	-225	-15.35	-31.47	0.30	0.44	0.25	-16.80	-33.00	3.40	0.20	0.80	1.20	0.28	1.11	-15.69	-32.72	-0.34	-1.25	0.28	1.15	-0.06	-0.10
340	0	-275	-15.35	-31.47	0.30	0.44	0.25	-16.80	-33.00	3.40	0.20	0.80	1.20	0.28	1.13	-15.79	-32.72	-0.34	-1.25	0.28	1.15	-0.06	-0.10
340	0	0	-7.48	-23.60	0.00	0.00	0.46	-9.00	-24.80	5.20	0.40	0.80	1.20	0.28	1.40	-7.80	-24.52	-1.12	-0.92	0.28	1.15	0.16	0.23
340	0	275	-12.22	-28.34	0.36	0.00	0.36	-13.70	-29.80	3.70	0.20	0.80	1.20	0.28	1.16	-12.54	-29.52	-0.32	-1.18	0.28	1.15	0.04	-0.03
340	-225	225	-15.35	-31.47	0.30	0.44	0.25	-16.80	-33.00	3.40	0.20	0.80	1.20	0.28	1.11	-15.69	-32.72	-0.34	-1.25	0.28	1.15	-0.06	-0.10
340	-225	-225	-15.35	-31.47	0.30	0.44	0.25	-16.70	-32.90	3.40	0.20	0.80	1.20	0.28	1.11	-15.59	-32.62	-0.24	-1.15	0.28	1.15	0.04	0.00
450	-275	0	-16.75	-32.87	0.34	0.29	0.29	-18.60	-34.90	3.30	0.20	0.70	1.20	0.28	1.09	-17.09	-34.74	-0.29	-1.20	0.28	1.15	-0.01	-0.15
450	-300	0	-20.73	-36.85	0.00	0.47	0.18	-22.10	-38.60	3.20	0.20	0.70	1.20	0.28	1.09	-21.04	-38.24	-0.31	-1.39	0.28	1.15	-0.03	-0.24
450	-300	300	-23.04	-39.16	0.31	0.41	0.14	-24.70	-41.10	3.10	0.20	0.80	1.20	0.28	1.06	-23.64	-40.62	-0.60	-1.66	0.28	1.15	-0.32	-0.51
450	-300	-300	-23.04	-39.16	0.31	0.41	0.14	-24.50	-41.00	3.10	0.20	0.80	1.20	0.28	1.06	-23.44	-40.72	-0.40	-1.56	0.28	1.15	-0.12	-0.41
450	-250	0	-16.75	-32.87	0.00	0.34	0.29	-18.10	-34.30	3.30	0.30	0.80	1.20	0.28	1.09	-17.01	-34.02	-0.26	-1.15	0.28	1.15	0.02	0.00
450	-200	200	-17.22	-33.34	0.20	0.27	0.29	-18.60	-34.90	3.30	0.20	0.80	1.20	0.28	1.09	-17.51	-34.54	-0.29	-1.20	0.28	1.15	-0.01	-0.15
450	-200	-200	-17.22	-33.34	0.20	0.27	0.29	-18.70	-35.00	3.20	0.20	0.80	1.20	0.28	1.08	-17.62	-34.72	-0.40	-1.30	0.28	1.15	-0.12	-0.23
450	0	-250	-16.70	-31.82	0.25	0.00	0.34	-17.10	-33.30	3.30	0.20	0.70	1.20	0.28	1.09	-16.01	-33.04	-0.31	-1.22	0.28	1.15	-0.03	-0.07
450	0	0	-12.83	-28.75	0.00	0.00	0.40	-14.00	-30.10	3.70	0.30	0.80	1.20	0.28	1.16	-12.84	-29.62	-0.21	-1.07	0.28	1.15	0.07	0.08
450	0	250	-16.70	-31.82	0.25	0.00	0.34	-17.20	-33.30	3.30	0.20	0.80	1.20	0.28	1.09	-16.11	-33.02	-0.41	-1.20	0.28	1.15	-0.13	-0.05
450	0	-250	-16.75	-32.84	0.36	0.00	0.27	-18.20	-34.60	3.20	0.20	0.80	1.20	0.28	1.09	-17.51	-34.54	-0.29	-1.20	0.28	1.15	-0.22	-0.35
450	200	200	-17.22	-33.34	0.20	0.27	0.29	-18.70	-35.00	3.20	0.20	0.80	1.20	0.28	1.08	-17.62	-34.72	-0.40	-1.30	0.28	1.15	-0.12	-0.23
450	200	-200	-17.22	-33.34	0.20	0.27	0.29	-18.60	-34.90	3.30	0.20	0.80	1.20	0.28	1.09	-17.51	-34.62	-0.29	-1.20	0.28	1.15	-0.01	-0.13
450	250	0	-16.75	-32.87	0.00	0.34	0.29	-18.20	-34.40	3.30	0.20	0.80	1.20	0.28	1.09	-17.11	-34.12	-0.36	-1.25	0.28	1.15	-0.08	-0.10
450	300	300	-23.04	-39.16	0.31	0.41	0.14	-24.60	-41.00	3.10	0.20	0.80	1.20	0.28	1.06	-23.74	-41.12	-0.70	-1.96	0.28	1.15	-0.42	-0.81
450	300	-300	-23.04	-39.16	0.31	0.41	0.14	-24.70	-41.20	3.10	0.20	0.70	1.20	0.28	1.06	-23.64	-40.94	-0.60	-1.78	0.28	1.15	-0.33	-0.63
450	350	0	-20.73	-36.85	0.00	0.47	0.18	-22.30	-38.70	3.10	0.20	0.80	1.20	0.28	1.08	-21.24	-38.42	-0.51	-1.57	0.28	1.15	-0.23	-0.42
			Difference in x-position [cm]			0.00									Std. dev			0.16			0.28		
			Difference in y-position [cm]			0.00									Max			-0.02			-0.75		
			Difference in z-position [cm]			0.00									Min			-0.70			-1.96		
			B-factor, up-link			0.88			-1.15 dB						Max-Min			0.68			1.21		
			B-factor, tele-powering			0.97			-0.28 dB						Average			-0.27			-1.15		

Ref. Loop 3 & 4, 180 deg			Calculated	Derivatives			Measured		Transmitting reference loop impedance (Z _u)				Compensation		Compensated		Difference		Pos. and Mch.		Difference		
Positioning parameters			attenuation	z			attenuation		Reference loop number 3				factor		attenuation		measured-calculated		Correction		measured-corrected		
Height, z [mm]	Lateral y [mm]	Long. x [mm]	Tele-powering, [dB]	Up-link, [dB]	z deviation [dB/cm]	y deviation [dB/cm]	x deviation [dB/cm]	(T) Tele-powering, [dB]	(U) Up-link, [dB]	(T) Tele-powering resistance, [dB]	(U) Tele-powering resistance, [dB]	(U) Up-link resistance, [dB]	(U) Up-link reactance, [dB]	Up-link, [dB]	Tele-powering, [dB]	Tele-powering, [dB]	Up-link, [dB]	Tele-powering, [dB]	Up-link, [dB]	Tele-powering, [dB]	Up-link, [dB]	Tele-powering, [dB]	Up-link, [dB]
220	-200	0	-8.63	-22.75	0.00	0.56	0.38	-8.30	-24.00	5.70	0.30	0.80	1.20	0.28	1.46	-8.84	-23.74	-1.21	-0.99	0.27	1.16	0.08	0.17
220	-150	0	-4.35	-20.47	0.00	0.40	0.45	-6.20	-21.60	7.60	0.40	0.80	1.20	0.26	1.75	-4.45	-21.34	-1.10	-0.87	0.27	1.16	0.07	0.29
220	-150	200	-7.74	-23.86	0.33	0.42	0.36	-9.30	-25.10	5.10	0.20	0.80	1.20	0.26	1.37	-7.93	-24.84	-1.19	-0.98	0.27	1.16	0.08	0.18
220	-150	-200	-7.74	-23.86	0.33	0.42	0.36	-9.20	-25.10	5.10	0.20	0.80	1.20	0.26	1.37	-7.93	-24.84	-1.19	-0.98	0.27	1.16	0.08	0.18
220	-100	-100	-3.62	-19.74	0.18	0.27	0.47	-5.60	-20.80	8.40	0.50	0.80	1.20	0.28	1.87	-3.73	-20.62	-1.11	-0.88	0.27	1.16	0.16	0.28
220	0	250	-6.48	-22.60	0.40	0.00	0.44	-8.10	-23.80	5.80	0.30	0.80	1.20	0.26	1.48	-6.62	-23.54	-1.14	-0.94	0.27	1.16	0.13	0.22
220	0	150	-3.33	-19.45	0.25	0.00	0.49	-5.40	-20.60	8.80	0.50	0.80	1.20	0.28	1.93	-3.47	-20.32	-1.14	-0.87	0.27	1.16	0.13	0.29
220																							

Ref. Loop 3 & 1, 180 deg			Calculated attenuation	Derivatives			Measured attenuation	Transmitting reference loop impedance (Z _u)			Compensation factor		Compensated attenuation	Difference measured-calculated		Pos. and Mch. Correction		Difference measured-corrected					
Height, z [mm]	Lateral, y [mm]	Long, x [mm]	Telem. power [dB]	Up-link [dB]	z deviation [dB/cm]	y deviation [dB/cm]	x deviation [dB/cm]	(0) Telem. power [dB]	(0) Up-link [dB]	(0) Telem. power reactance [dB]	(0) Telem. power reactance [dB]	(0) Up-link reactance [dB]	Up-link [dB]	Telem. power [dB]	Telem. power [dB]	Up-link [dB]	Telem. power [dB]	Up-link [dB]	Telem. power [dB]	Up-link [dB]			
220	-200	0	-8.63	-22.75	0.00	0.56	0.38	-8.20	-24.00	5.70	0.30	0.80	1.20	0.26	1.46	-8.74	-23.74	-0.11	-0.99	0.27	1.16	0.18	0.17
220	-150	0	-4.35	-20.47	0.00	0.40	0.45	-6.20	-21.60	7.60	0.50	0.80	1.20	0.26	1.75	-4.45	-21.34	-0.10	-0.87	0.27	1.16	0.17	0.29
220	-150	200	-7.74	-23.86	0.33	0.42	0.36	-9.30	-25.10	5.10	0.30	0.80	1.20	0.26	1.37	-7.93	-24.84	-0.19	-0.98	0.27	1.16	0.08	0.18
220	-150	-200	-7.74	-23.86	0.33	0.42	0.36	-9.30	-25.10	5.10	0.30	0.80	1.20	0.26	1.37	-7.93	-24.84	-0.19	-0.98	0.27	1.16	0.18	0.18
220	-100	-100	-3.62	-19.74	0.18	0.27	0.47	-5.60	-20.90	8.40	0.50	0.90	1.20	0.28	1.89	-3.71	-20.62	-0.09	-0.88	0.27	1.16	0.18	0.28
220	0	250	-6.48	-22.60	0.40	0.00	0.44	-8.10	-23.80	5.90	0.30	0.80	1.20	0.26	1.46	-6.74	-23.54	-0.26	-0.94	0.27	1.16	0.01	0.22
220	0	150	-3.33	-19.45	0.25	0.00	0.49	-5.40	-20.60	8.00	0.50	0.90	1.20	0.28	1.93	-3.47	-20.32	-0.14	-0.87	0.27	1.16	0.13	0.29
220	0	-1.43	-17.55	-0.00	0.00	0.55	-3.80	-18.60	12.10	0.70	0.90	1.20	0.28	2.41	-1.39	-18.32	0.04	-0.77	0.27	1.16	0.31	0.39	
220	0	-1.50	-3.33	-19.45	0.25	0.00	0.49	-5.30	-20.60	8.90	0.50	0.90	1.20	0.28	1.95	-3.35	-20.32	-0.02	-0.87	0.27	1.16	0.35	0.29
220	0	-250	-6.48	-22.60	0.40	0.00	0.44	-8.10	-23.80	5.90	0.30	0.80	1.20	0.26	1.48	-6.62	-23.54	-0.14	-0.94	0.27	1.16	0.13	0.22
220	100	-100	-3.62	-19.74	0.18	0.27	0.47	-5.60	-20.90	8.40	0.50	0.90	1.20	0.28	1.89	-3.71	-20.62	-0.09	-0.88	0.27	1.16	0.18	0.28
220	100	100	-3.62	-19.74	0.18	0.27	0.47	-5.60	-20.90	8.40	0.50	0.90	1.20	0.28	1.87	-3.73	-20.62	-0.11	-0.88	0.27	1.16	0.16	0.28
220	150	200	-7.74	-23.86	0.33	0.42	0.36	-9.30	-25.20	5.10	0.20	0.80	1.20	0.26	1.37	-7.93	-24.94	-0.19	-1.08	0.27	1.16	0.08	0.08
220	150	-200	-7.74	-23.86	0.33	0.42	0.36	-9.30	-25.10	5.10	0.20	0.80	1.20	0.26	1.37	-7.93	-24.84	-0.19	-0.98	0.27	1.16	0.08	0.18
220	200	0	-4.35	-20.47	0.00	0.40	0.45	-6.20	-21.60	7.60	0.40	0.80	1.20	0.26	1.75	-4.45	-21.34	-0.10	-0.87	0.27	1.16	0.17	0.29
220	200	0	-8.63	-22.75	0.00	0.56	0.38	-8.20	-24.00	5.70	0.20	0.80	1.20	0.26	1.46	-8.84	-23.74	-0.21	-0.99	0.27	1.16	0.08	0.17
340	275	0	-14.48	-30.60	0.00	0.54	0.25	-15.90	-32.10	3.50	0.20	0.80	1.20	0.28	1.11	-14.79	-31.84	-0.31	-1.24	0.27	1.16	-0.04	-0.08
340	225	225	-15.35	-31.47	0.30	0.44	0.25	-16.80	-33.10	3.40	0.20	0.80	1.20	0.28	1.09	-15.81	-32.84	-0.46	-1.37	0.27	1.16	-0.19	-0.21
340	225	-225	-15.35	-31.47	0.30	0.44	0.25	-16.80	-33.00	3.40	0.20	0.80	1.20	0.28	1.09	-15.71	-32.75	-0.36	-1.28	0.27	1.16	-0.09	-0.12
340	0	-1.50	-3.33	-19.45	0.25	0.00	0.54	-5.30	-20.60	8.90	0.50	0.90	1.20	0.28	1.95	-3.35	-20.32	-0.02	-0.87	0.27	1.16	0.35	0.29
340	0	0	-7.48	-23.60	0.00	0.00	0.46	-9.00	-24.80	5.20	0.30	0.80	1.20	0.26	1.38	-7.82	-24.54	-0.14	-0.94	0.27	1.16	0.13	0.22
340	0	275	-12.22	-28.34	0.36	0.00	0.36	-13.70	-29.70	3.70	0.20	0.80	1.20	0.28	1.14	-12.56	-28.44	-0.34	-1.10	0.27	1.16	-0.07	-0.06
340	-225	225	-15.35	-31.47	0.30	0.44	0.25	-16.80	-33.00	3.40	0.20	0.80	1.20	0.28	1.09	-15.71	-32.75	-0.36	-1.27	0.27	1.16	-0.09	-0.11
340	-225	-225	-15.35	-31.47	0.30	0.44	0.25	-16.70	-32.90	3.40	0.20	0.80	1.20	0.28	1.09	-15.61	-32.64	-0.26	-1.17	0.27	1.16	-0.01	-0.01
340	-275	0	-14.48	-30.60	0.00	0.54	0.25	-15.90	-32.10	3.50	0.20	0.80	1.20	0.28	1.11	-14.79	-31.84	-0.31	-1.24	0.27	1.16	-0.06	-0.02
450	-300	0	-20.73	-36.85	0.00	0.47	0.18	-22.10	-38.60	3.20	0.20	0.70	1.20	0.25	1.06	-21.04	-36.25	-0.31	-1.40	0.27	1.16	-0.04	-0.24
450	-300	300	-23.04	-39.16	0.31	0.41	0.14	-24.60	-41.10	3.10	0.20	0.70	1.20	0.25	1.05	-23.55	-40.85	-0.51	-1.69	0.27	1.16	-0.24	-0.53
450	-300	-300	-23.04	-39.16	0.31	0.41	0.14	-24.50	-41.00	3.10	0.20	0.70	1.20	0.25	1.05	-23.45	-40.75	-0.41	-1.59	0.27	1.16	-0.14	-0.43
450	-250	0	-16.75	-32.87	0.00	0.34	0.29	-18.10	-34.30	3.30	0.30	0.80	1.20	0.26	1.08	-17.02	-34.04	-0.27	-1.17	0.27	1.16	0.00	-0.01
450	-200	200	-17.22	-33.34	0.20	0.27	0.29	-18.60	-34.80	3.20	0.20	0.80	1.20	0.26	1.08	-17.52	-34.54	-0.30	-1.20	0.27	1.16	-0.03	-0.04
450	-200	-200	-17.22	-33.34	0.20	0.27	0.29	-18.50	-34.70	3.20	0.20	0.80	1.20	0.26	1.08	-17.42	-34.44	-0.20	-1.20	0.27	1.16	0.07	0.02
450	0	-350	-18.72	-34.84	0.36	0.00	0.27	-20.10	-36.50	3.20	0.20	0.70	1.20	0.25	1.06	-19.04	-36.25	-0.32	-1.41	0.27	1.16	-0.05	-0.25
450	0	-250	-15.70	-31.82	0.25	0.00	0.34	-17.10	-33.30	3.40	0.20	0.80	1.20	0.26	1.09	-16.01	-33.04	-0.31	-1.22	0.27	1.16	-0.04	-0.06
450	0	0	-12.83	-28.75	0.00	0.00	0.40	-14.00	-30.10	3.70	0.30	0.80	1.20	0.26	1.14	-12.86	-28.84	-0.23	-1.09	0.27	1.16	0.04	0.07
450	0	250	-15.70	-31.82	0.25	0.00	0.34	-17.10	-33.30	3.40	0.20	0.80	1.20	0.26	1.08	-16.02	-33.04	-0.32	-1.22	0.27	1.16	-0.05	-0.06
450	0	350	-18.72	-34.84	0.36	0.00	0.27	-20.10	-36.50	3.20	0.20	0.70	1.20	0.25	1.06	-19.14	-36.25	-0.41	-1.27	0.27	1.16	-0.15	-0.25
450	200	200	-17.22	-33.34	0.20	0.27	0.29	-18.70	-34.90	3.20	0.20	0.80	1.20	0.26	1.06	-17.64	-34.64	-0.42	-1.30	0.27	1.16	-0.15	-0.14
450	200	-200	-17.22	-33.34	0.20	0.27	0.29	-18.60	-34.80	3.20	0.20	0.80	1.20	0.26	1.08	-17.52	-34.64	-0.30	-1.30	0.27	1.16	-0.03	-0.14
450	250	0	-16.75	-32.87	0.00	0.34	0.29	-18.10	-34.30	3.30	0.20	0.80	1.20	0.26	1.08	-17.02	-34.14	-0.27	-1.27	0.27	1.16	0.00	-0.11
450	300	300	-23.04	-39.16	0.31	0.41	0.14	-24.60	-41.30	3.10	0.20	0.80	1.20	0.26	1.05	-23.75	-41.04	-0.71	-1.88	0.27	1.16	-0.44	-0.72
450	300	-300	-23.04	-39.16	0.31	0.41	0.14	-24.70	-41.20	3.10	0.20	0.80	1.20	0.26	1.05	-23.65	-40.94	-0.61	-1.78	0.27	1.16	-0.34	-0.62
450	350	0	-20.73	-36.85	0.00	0.47	0.18	-22.30	-38.70	3.20	0.20	0.80	1.20	0.26	1.06	-21.24	-36.44	-0.51	-1.59	0.27	1.16	-0.24	-0.43
			Difference in x-position [cm]			0.00								Std. dev		0.16		0.27					
			Difference in y-position [cm]			0.00								Max		0.04		-0.77				0.31	
			Difference in z-position [cm]			0.00								Min		-0.71		-1.86				-0.44	
			B-factor, up-link			0.87			-1.16 dB					Max-Min		0.75		1.11				0.75	
			B-factor, tele-powering			0.97			-0.27 dB					Average		-0.26		-1.16				0.91	

Ref. Loop 2 & 3, 0 deg			Calculated attenuation	Derivatives			Measured attenuation	Transmitting reference loop impedance (Z _u)			Compensation factor		Compensated attenuation	Difference measured-calculated		Pos. and Mch. Correction		Difference measured-corrected					
Height, z [mm]	Lateral, y [mm]	Long, x [mm]	Telem. power [dB]	Up-link [dB]	z deviation [dB/cm]	y deviation [dB/cm]	x deviation [dB/cm]	(0) Telem. power [dB]	(0) Up-link [dB]	(0) Telem. power reactance [dB]	(0) Telem. power reactance [dB]	(0) Up-link reactance [dB]	Up-link [dB]	Telem. power [dB]	Telem. power [dB]	Up-link [dB]	Telem. power [dB]	Up-link [dB]	Telem. power [dB]	Up-link [dB]			
220	-200	0	-8.63	-22.75	0.00	0.56	0.38	-8.30	-24.00	5.90	0.70	0.90	0.70	0.28	1.50	-8.80	-23.72	-0.17	-0.97	0.21	1.13	0.04	0.16
220	-150	0	-4.35	-20.47	0.00	0.40	0.45	-6.20	-21.60	7.60	0.80	0.80	0.70	0.28	1.79	-4.41	-21.32	-0.06	-0.85	0.21	1.13	0.15	0.28
220	-150	200	-7.74	-23.86	0.33	0.42	0.36	-9.30	-25.10	5.20	0.60	0.90	0.70	0.28	1.39	-7.91	-24.82	-0.17	-0.96	0.21	1.13	0.04	0.17
220	-150	-200	-7.74	-23.86	0.33	0.42	0.36	-9.30	-25.10	5.40	0.70	0.90	0.70	0.28	1.42	-7.88	-24.82	-0.14	-0.86	0.21	1.13	0.07	0.17
220	-100	-100	-3.62	-19.74	0.18	0.27	0.47	-5.60	-20.90	8.70	0.80	1.00	0.70	0.30	1.92	-3.69	-20.60	-0.06	-0.85	0.21	1.13	0.15	0.27
220	0	250	-6.48	-22.60	0.40	0.00	0.44	-8.10	-23.80	6.60	0.80	1.00	0.70	0.30	1.91	-6.59	-23.52	-0.12	-0.92	0.21	1.13	0.09	0.21
220	0	150	-3.33	-19.45	0.25	0.00	0.49	-5.30	-20.60	9.00	1.00	1.00	0.70	0.30	1.97	-3.33	-20.30	0.00	-0.85	0.21	1.13	0.21	0.28
220	0	-1.43</																					

Ref. Loop 2 & 3, 180 deg			Calculated attenuation		Derivatives			Measured attenuation		Transmitting reference loop impedance (Z ₀)			Compensation factor		Compensated attenuation		Difference: measured-calculated		Pos. and Match. Correction		Difference: measured-corrected																			
Height, z [mm]	Lateral y [mm]	Long. x [mm]	Tele-powering [dB]	Up-link [dB]	z-deviation [dB/cm]	y-deviation [dB/cm]	x-deviation [dB/cm]	(0) Tele-powering [dB]	(0) Up-link [dB]	(0) Tele-powering reactance [dB]	(0) Tele-powering inductance [dB]	(0) Up-link reactance [dB]	(0) Tele-powering [dB]	Up-link [dB]	Tele-powering [dB]	Tele-powering [dB]	Up-link [dB]	Tele-powering [dB]	Up-link [dB]	Tele-powering [dB]	Up-link [dB]	Tele-powering [dB]	Up-link [dB]																	
220	-200	0	-8.63	-22.75	0.00	0.56	0.39	-8.20	-23.90	5.60	0.70	0.90	0.70	0.28	1.49	-8.71	-23.62	-0.08	-0.87	0.21	1.13	0.13	0.28																	
220	-150	0	-4.35	-20.47	0.00	0.40	0.45	-6.20	-21.60	7.70	0.60	0.90	0.70	0.28	1.78	-4.42	-21.32	-0.07	-0.85	0.21	1.13	0.14	0.28																	
220	-150	200	-7.74	-23.86	0.33	0.42	0.36	-9.30	-25.10	5.20	0.70	0.90	0.70	0.28	1.40	-7.90	-24.82	-0.16	-0.96	0.21	1.13	0.05	0.17																	
220	-150	-200	-7.74	-23.86	0.33	0.42	0.36	-9.20	-25.00	5.30	0.70	0.90	0.70	0.28	1.42	-7.78	-24.72	-0.04	-0.86	0.21	1.13	0.17	0.27																	
220	-100	-100	-3.62	-19.74	0.18	0.27	0.47	-5.60	-20.90	8.70	0.60	0.90	0.70	0.28	1.93	-3.57	-20.52	0.05	-0.78	0.21	1.13	0.28	0.35																	
220	-100	100	-3.62	-19.74	0.18	0.27	0.47	-5.60	-20.90	8.50	0.60	1.00	0.70	0.30	1.90	-3.70	-20.60	-0.08	-0.86	0.21	1.13	0.13	0.27																	
220	0	250	-6.48	-22.60	0.40	0.00	0.44	-6.20	-23.90	5.60	0.70	0.90	0.70	0.28	1.49	-6.71	-23.62	-0.23	-1.02	0.21	1.13	-0.02	0.11																	
220	0	150	-3.33	-19.45	0.25	0.00	0.49	-5.40	-20.60	8.90	0.90	1.00	0.70	0.30	1.96	-3.44	-20.30	-0.11	-0.85	0.21	1.13	0.10	0.28																	
220	0	-150	-3.33	-19.45	0.25	0.00	0.49	-5.30	-20.50	9.10	0.60	1.00	0.70	0.30	1.99	-3.31	-20.20	0.02	-0.85	0.21	1.13	0.23	0.38																	
220	0	-250	-6.48	-22.60	0.40	0.00	0.44	-6.00	-23.70	6.00	0.70	0.90	0.70	0.28	1.52	-6.48	-23.42	0.00	-0.82	0.21	1.13	0.21	0.31																	
220	100	-100	-3.62	-19.74	0.18	0.27	0.47	-5.50	-20.80	8.70	0.60	1.00	0.70	0.30	1.93	-3.57	-20.50	0.05	-0.76	0.21	1.13	0.28	0.37																	
220	100	100	-3.62	-19.74	0.18	0.27	0.47	-5.60	-20.90	8.60	0.60	1.00	0.70	0.30	1.92	-3.68	-20.60	-0.06	-0.86	0.21	1.13	0.15	0.27																	
220	150	200	-7.74	-23.86	0.33	0.42	0.36	-9.40	-25.20	5.20	0.60	0.90	0.70	0.28	1.40	-8.00	-24.92	-0.26	-1.06	0.21	1.13	-0.05	0.07																	
220	150	-200	-7.74	-23.86	0.33	0.42	0.36	-9.20	-25.00	5.30	0.60	0.90	0.70	0.28	1.42	-7.78	-24.72	-0.04	-0.86	0.21	1.13	0.17	0.27																	
220	150	0	-4.35	-20.47	0.00	0.40	0.45	-6.20	-21.60	7.60	0.60	0.90	0.70	0.28	1.90	-4.40	-21.32	-0.05	-0.85	0.21	1.13	0.16	0.28																	
220	200	0	-8.63	-22.75	0.00	0.56	0.39	-8.30	-24.00	5.90	0.60	0.90	0.70	0.28	1.51	-8.79	-23.72	-0.16	-0.97	0.21	1.13	0.05	0.16																	
340	275	0	-14.48	-30.60	0.00	0.54	0.25	-15.90	-32.10	3.60	0.60	0.80	0.70	0.28	1.14	-14.76	-31.84	-0.28	-1.24	0.21	1.13	-0.07	-0.11																	
340	225	225	-15.35	-31.47	0.30	0.44	0.25	-16.90	-33.20	3.50	0.60	0.90	0.70	0.28	1.13	-15.77	-32.92	-0.42	-1.45	0.21	1.13	-0.21	-0.32																	
340	225	-225	-15.35	-31.47	0.30	0.44	0.25	-16.70	-32.90	3.50	0.60	0.90	0.70	0.28	1.13	-15.57	-32.62	-0.22	-1.15	0.21	1.13	-0.01	-0.02																	
340	0	-275	-12.22	-28.34	0.36	0.02	0.36	-13.50	-29.60	3.90	0.60	0.90	0.70	0.28	1.19	-12.21	-28.20	-0.09	-0.98	0.21	1.13	0.12	0.15																	
340	0	-275	-12.22	-28.34	0.36	0.00	0.46	-13.00	-29.40	3.40	0.70	0.90	0.70	0.28	1.43	-12.57	-24.52	-0.09	-0.92	0.21	1.13	0.12	0.21																	
340	0	275	-12.22	-28.34	0.36	0.00	0.36	-13.70	-29.80	3.80	0.60	0.80	0.70	0.28	1.18	-12.52	-29.54	-0.30	-1.20	0.21	1.13	-0.09	-0.07																	
340	-225	225	-15.35	-31.47	0.30	0.44	0.25	-16.80	-33.00	3.50	0.60	0.80	0.70	0.28	1.13	-15.67	-32.74	-0.32	-1.27	0.21	1.13	-0.11	-0.14																	
340	-225	-225	-15.35	-31.47	0.30	0.44	0.25	-16.60	-32.80	3.50	0.60	0.90	0.70	0.28	1.13	-15.47	-32.52	-0.12	-1.05	0.21	1.13	0.09	0.08																	
340	-275	0	-14.48	-30.60	0.00	0.54	0.25	-15.80	-32.00	3.50	0.60	0.90	0.70	0.28	1.13	-14.67	-30.72	-0.19	-1.12	0.21	1.13	0.02	0.01																	
450	-300	0	-20.73	-36.85	0.00	0.47	0.18	-22.10	-38.50	3.20	0.70	0.90	0.70	0.28	1.10	-21.08	-36.24	-0.09	-0.92	0.21	1.13	-0.06	-0.06																	
450	-300	300	-23.04	-39.16	0.31	0.41	0.14	-24.60	-41.10	3.10	0.60	0.80	0.70	0.28	1.06	-23.54	-40.84	-0.50	-1.68	0.21	1.13	-0.29	-0.55																	
450	-300	-300	-23.04	-39.16	0.31	0.41	0.14	-24.40	-41.00	3.20	0.70	0.80	0.70	0.28	1.08	-23.32	-40.74	-0.28	-1.58	0.21	1.13	-0.07	-0.45																	
450	-250	0	-16.75	-32.87	0.00	0.34	0.29	-18.00	-34.30	3.40	0.60	0.80	0.70	0.28	1.11	-16.89	-34.04	-0.14	-1.17	0.21	1.13	0.07	-0.04																	
450	-200	200	-17.22	-33.34	0.20	0.27	0.29	-19.60	-34.90	3.40	0.60	0.90	0.70	0.28	1.11	-17.49	-34.62	-0.27	-1.28	0.21	1.13	-0.06	-0.15																	
450	-200	-200	-17.22	-33.34	0.20	0.27	0.29	-19.50	-34.80	3.40	0.60	0.90	0.70	0.28	1.11	-17.31	-34.54	-0.44	-1.50	0.21	1.13	-0.27	-0.37																	
450	0	-350	-18.72	-34.84	0.36	0.00	0.27	-20.00	-36.40	3.30	0.60	0.80	0.70	0.28	1.10	-18.90	-36.14	-0.16	-1.30	0.21	1.13	0.03	-0.17																	
450	0	-250	-15.70	-31.82	0.00	0.34	0.17	-17.00	-33.20	3.50	0.60	0.80	0.70	0.28	1.13	-15.87	-32.94	-0.17	-1.12	0.21	1.13	0.04	0.01																	
450	0	-12.83	-28.75	0.00	0.00	0.40	0.34	-17.10	-33.10	3.60	0.70	0.90	0.70	0.28	1.18	-12.72	-28.62	-0.09	-1.07	0.21	1.13	0.12	0.16																	
450	0	250	-15.70	-31.82	0.25	0.00	0.34	-17.10	-33.40	3.40	0.60	0.90	0.70	0.28	1.11	-15.99	-33.12	-0.29	-1.30	0.21	1.13	-0.08	-0.17																	
450	0	250	-15.70	-31.82	0.25	0.00	0.34	-17.20	-33.50	3.30	0.60	0.90	0.70	0.28	1.10	-15.81	-33.04	-0.44	-1.50	0.21	1.13	-0.27	-0.37																	
450	200	200	-17.22	-33.34	0.20	0.27	0.29	-18.70	-35.00	3.40	0.60	0.80	0.70	0.28	1.11	-17.59	-34.74	-0.37	-1.40	0.21	1.13	-0.16	-0.27																	
450	200	-200	-17.22	-33.34	0.20	0.27	0.29	-18.50	-34.80	3.40	0.60	0.80	0.70	0.28	1.11	-17.39	-34.54	-0.17	-1.20	0.21	1.13	0.04	-0.07																	
450	250	0	-16.75	-32.87	0.00	0.34	0.29	-18.10	-34.40	3.40	0.60	0.90	0.70	0.28	1.11	-16.99	-34.12	-0.24	-1.25	0.21	1.13	-0.03	-0.12																	
450	300	300	-23.04	-39.16	0.31	0.41	0.14	-24.90	-41.40	3.20	0.60	0.80	0.70	0.28	1.08	-23.82	-41.14	-0.78	-1.98	0.21	1.13	-0.57	-0.85																	
450	300	-300	-23.04	-39.16	0.31	0.41	0.14	-24.60	-41.10	3.20	0.60	0.80	0.70	0.28	1.08	-23.52	-40.84	-0.48	-1.68	0.21	1.13	-0.27	-0.55																	
450	350	0	-20.73	-36.85	0.00	0.47	0.18	-22.30	-38.70	3.20	0.60	0.80	0.70	0.28	1.08	-21.22	-36.44	-0.49	-1.59	0.21	1.13	-0.28	-0.46																	
																		Std. dev.	0.18		0.28																			
																		Max.	0.08		-0.75	0.29		0.38																
																		Min.	-0.78		-1.98	-0.57		-0.85																
																		Max-Min	0.86		1.22	0.86		1.22																
																		Average	-0.20		-1.14	-0.51		-0.61																

Positioning parameters			Standard Size 0 deg						Standard Size 180 deg					
Height, z [mm]	Lateral y [mm]	Long. x [mm]	Error 1, Up-link [dB]	Error 1, Tele-power [dB]	Error 2, Up-link [dB]	Error 2, Tele-power [dB]	Error 3, Up-link [dB]	Error 3, Tele-power [dB]	Error 1, Up-link [dB]	Error 1, Tele-power [dB]	Error 2, Up-link [dB]	Error 2, Tele-power [dB]	Error 3, Up-link [dB]	Error 3, Tele-power [dB]
220	-200	0	0.10	0.01	0.09	-0.02	0.08	0.05	0.10	0.06	0.18	0.03	0.08	0.10
220	-150	0	0.11	0.06	0.09	0.04	0.19	0.11	0.16	0.11	0.14	0.09	0.14	0.06
220	-150	200	0.10	0.07	0.09	0.03	0.08	0.00	0.10	0.07	0.09	0.04	0.08	0.01
220	-150	-200	0.05	0.01	0.04	0.00	0.13	0.07	0.10	0.11	0.15	0.10	0.19	0.19
220	-100	-100	0.15	0.05	0.14	0.04	0.13	0.11	0.16	0.06	0.23	0.15	0.12	0.12
220	-100	100	0.15	0.11	0.14	0.08	0.13	0.05	0.15	0.11	0.14	0.08	0.13	0.05
220	0	250	0.12	0.05	0.11	0.01	0.10	0.08	0.12	0.03	0.01	0.01	0.10	-0.02
220	0	150	0.16	0.04	0.14	0.12	0.14	0.09	0.16	0.09	0.14	0.06	0.14	0.05
220	0	-150	0.15	0.07	0.19	0.15	0.19	0.15	0.21	0.12	0.15	0.10	0.19	0.19
220	0	-250	0.11	0.08	0.19	0.06	0.19	0.15	0.11	0.14	0.19	0.12	0.19	0.11
220	0	-250	0.07	0.04	0.06	0.00	0.15	0.09	0.07	0.03	0.16	0.12	0.15	0.09
220	100	-100	0.10	0.06	0.19	0.13	0.18	0.10	0.10	0.05	0.19	0.14	0.18	0

B2.7.3 Reduced Size Reference Loop

Tested units in this sheet		Free air impedance (Z _a)				
Reduced size Reference Loops		Tele-powering		Up-link		
Number	Rev.	SN	re (Ohm)	in (Ohm)	re (Ohm)	in (Ohm)
1	RTA	RX1	2.5	0.1	0.4	0.1
2	RTA	RX2	2.5	0.0	0.4	-0.1
3	RTA	RX3	2.5	-0.2	0.5	-0.2

Differences in x-, y-, and z positions indicate how far from the Reference Mark the Electrical Centre is located.
B factors indicate the actual Matching Transfer Ratio of the device.

Please observe also "definitions" and "instructions" further down.

* The letters in the parentheses defines which measurement series the data is taken in the column.
* 0 deg means that the reference loops are in parallel to each other, i.e. the connectors are at the same direction for both ref. loops.
* 180 deg means that the reference loops are in anti-parallel to each other, i.e. the connectors are at the opposite direction for the both ref. loops.

Ref. Loop 1 & 2, 0 deg	Positioning parameters			Calculated attenuation	Derivatives			Measured attenuation		Transmitting reference loop impedance (Z _{in})		Compensation factor		Compensated attenuation		Difference measured-calculated		Pos. and Match Correction		Difference measured-corrected					
	Height, z (mm)	Lateral y (mm)	Long x (mm)		Tele-powering, (dB)	Up-link, (dB)	z-deviation (dB/cm)	y-deviation (dB/cm)	x-deviation (dB/cm)	(b) Tele-powering, (dB)	(a) Up-link, (dB)	(b) Tele-powering, (dB)	(a) Up-link, (dB)	Tele-powering, (dB)	Up-link, (dB)	Tele-powering, (dB)	Up-link, (dB)	Tele-powering, (dB)	Up-link, (dB)	Tele-powering, (dB)	Up-link, (dB)				
220	-200	0	-21.26	-37.40	0.12	1.14	0.00	-22.10	-38.50	2.50	0.10	0.40	0.10	0.14	0.85	-21.25	-38.36	0.03	-0.96	0.18	1.27	0.21	0.31		
220	-150	0	-16.58	-32.70	0.41	0.81	0.00	-17.40	-33.80	2.70	0.20	0.40	0.10	0.14	0.88	-16.52	-33.66	0.06	-0.96	-0.01	1.08	0.55	0.12		
220	-150	200	-21.22	-37.34	0.26	0.86	0.48	-21.90	-38.40	2.50	0.10	0.40	0.10	0.14	0.85	-21.05	-38.26	0.17	-0.92	-0.02	1.07	0.15	0.15		
220	-150	-200	-21.22	-37.34	0.26	0.86	0.48	-22.30	-38.70	2.50	0.20	0.40	0.10	0.14	0.85	-21.45	-38.56	-0.23	-1.22	0.22	1.31	-0.01	0.09		
220	-100	-100	-14.52	-30.64	0.54	0.54	0.24	-15.50	-31.80	2.80	0.20	0.40	0.10	0.14	0.90	-14.60	-31.66	-0.08	-1.02	-0.02	1.07	-0.11	0.04		
220	-100	100	-14.52	-30.64	0.54	0.54	0.24	-15.40	-31.60	2.90	0.20	0.40	0.10	0.14	0.91	-14.49	-31.46	0.03	-0.82	-0.14	0.95	-0.11	0.12		
220	0	250	-17.86	-33.98	0.53	0.00	0.60	-18.70	-35.00	2.90	0.10	0.40	0.10	0.14	0.86	-17.84	-34.86	0.02	-0.86	-0.16	0.93	-0.14	0.04		
220	0	150	-13.37	-29.49	0.63	0.00	0.34	-14.30	-30.50	3.00	0.20	0.40	0.10	0.14	0.93	-13.37	-30.36	0.00	-0.87	-0.18	0.91	-0.16	0.04		
220	0	0	-10.85	-26.97	0.70	0.00	0.00	-11.80	-28.00	3.50	0.20	0.40	0.10	0.14	1.01	-10.89	-27.86	-0.04	-0.89	-0.15	0.94	-0.19	0.05		
220	0	-150	-13.37	-29.49	0.63	0.00	0.34	-14.40	-30.60	3.00	0.20	0.40	0.10	0.14	0.93	-13.47	-30.46	-0.10	-0.97	-0.01	1.08	-0.11	0.11		
220	0	-250	-17.86	-33.98	0.53	0.00	0.60	-19.00	-35.30	2.60	0.10	0.40	0.10	0.14	0.86	-18.14	-35.16	-0.28	-1.18	0.14	1.23	-0.14	0.04		
220	100	-100	-14.52	-30.64	0.54	0.54	0.24	-15.50	-31.80	2.90	0.20	0.40	0.10	0.14	0.91	-14.59	-31.66	-0.07	-1.02	0.10	1.19	0.03	0.17		
220	100	100	-14.52	-30.64	0.54	0.54	0.24	-15.40	-31.70	2.90	0.20	0.40	0.10	0.14	0.91	-14.48	-31.56	0.03	-0.82	-0.02	1.07	0.01	0.15		
220	150	200	-21.22	-37.34	0.26	0.86	0.48	-22.20	-38.50	2.50	0.10	0.40	0.10	0.14	0.85	-21.35	-38.36	-0.13	-1.02	0.18	1.27	0.05	0.25		
220	150	-200	-21.22	-37.34	0.26	0.86	0.48	-22.30	-38.80	2.50	0.10	0.40	0.10	0.14	0.85	-21.45	-38.66	-0.23	-1.32	0.42	1.51	0.19	0.19		
220	150	0	-16.58	-32.70	0.41	0.81	0.00	-17.50	-33.90	2.70	0.20	0.40	0.10	0.14	0.88	-16.62	-33.66	-0.04	-0.96	0.18	1.27	0.14	0.30		
220	200	0	-16.58	-32.70	0.41	0.81	0.00	-17.50	-33.90	2.70	0.20	0.40	0.10	0.14	0.88	-16.52	-33.66	-0.07	-1.16	0.45	1.54	0.37	0.37		
340	225	0	-29.23	-45.35	0.09	0.79	0.00	-30.30	-46.50	2.40	0.20	0.40	0.10	0.14	0.83	-29.47	-46.76	-0.24	-1.41	0.43	1.52	0.19	0.11		
340	225	225	-29.90	-46.02	0.13	0.66	0.39	-31.00	-47.50	2.40	0.20	0.40	0.10	0.14	0.83	-30.17	-47.36	-0.27	-1.34	0.28	1.37	0.02	0.03		
340	225	-225	-29.90	-46.02	0.13	0.66	0.39	-31.10	-47.80	2.40	0.20	0.40	0.10	0.14	0.83	-30.27	-47.66	-0.37	-1.64	0.46	1.57	0.11	-0.07		
340	0	-275	-24.71	-40.83	0.40	0.00	0.48	-25.90	-42.40	2.40	0.20	0.40	0.10	0.14	0.83	-25.07	-42.26	-0.36	-1.43	0.21	1.30	-0.15	-0.13		
340	0	0	-18.39	-34.51	0.55	0.00	0.00	-19.30	-35.60	2.90	0.20	0.40	0.10	0.14	0.86	-18.44	-35.46	-0.05	-0.95	-0.03	1.06	-0.08	0.11		
340	0	275	-24.71	-40.83	0.40	0.00	0.48	-25.60	-42.00	2.50	0.20	0.40	0.10	0.14	0.85	-24.75	-41.86	-0.04	-1.03	-0.03	1.06	-0.07	0.03		
340	-225	225	-29.90	-46.02	0.13	0.66	0.39	-30.70	-47.40	2.40	0.20	0.40	0.10	0.14	0.83	-29.87	-47.26	0.03	-1.24	0.13	1.22	0.16	-0.02		
340	-225	-225	-29.90	-46.02	0.13	0.66	0.39	-31.10	-47.70	2.40	0.20	0.40	0.10	0.14	0.83	-30.27	-47.56	-0.37	-1.54	0.33	1.42	-0.04	-0.04		
340	-275	0	-29.23	-45.35	0.09	0.79	0.00	-30.10	-46.70	2.40	0.20	0.40	0.10	0.14	0.83	-29.27	-46.56	-0.04	-1.21	0.25	1.34	0.21	0.13		
450	-350	0	-35.26	-51.38	0.09	0.59	0.00	-36.30	-53.00	2.40	0.20	0.40	0.10	0.14	0.83	-35.47	-52.86	-0.21	-1.48	0.27	1.36	0.06	-0.12		
450	-300	300	-37.92	-54.04	0.04	0.52	0.38	-38.60	-56.00	2.40	0.20	0.40	0.10	0.14	0.83	-37.97	-55.86	-0.05	-1.82	0.22	1.31	0.17	-0.51		
450	-300	-300	-37.92	-54.04	0.04	0.52	0.38	-39.40	-56.20	2.40	0.20	0.40	0.10	0.14	0.83	-38.57	-56.06	-0.65	-2.02	0.41	1.50	-0.24	-0.52		
450	-250	0	-30.13	-46.25	0.27	0.44	0.00	-31.10	-47.70	2.40	0.20	0.40	0.10	0.14	0.83	-30.27	-47.56	-0.14	-1.31	0.14	1.23	0.00	-0.08		
450	-200	200	-30.56	-46.68	0.28	0.36	0.25	-31.40	-48.00	2.40	0.20	0.40	0.10	0.14	0.83	-30.57	-47.86	-0.01	-1.18	0.08	1.17	0.07	-0.10		
450	-200	-200	-30.56	-46.68	0.28	0.36	0.25	-31.70	-48.20	2.40	0.20	0.40	0.10	0.14	0.83	-30.87	-48.06	-0.31	-1.38	0.21	1.30	-0.10	-0.08		
450	0	-350	-32.11	-48.23	0.27	0.00	0.45	-33.40	-50.10	2.40	0.20	0.40	0.10	0.14	0.83	-32.57	-48.96	-0.46	-1.73	0.31	1.48	-0.15	-0.34		
450	0	-250	-29.34	-44.46	0.36	0.00	0.32	-29.50	-46.00	2.40	0.20	0.40	0.10	0.14	0.83	-29.67	-45.86	-0.33	-1.40	0.30	1.29	-0.13	-0.11		
450	0	0	-24.46	-40.58	0.45	0.00	0.00	-25.40	-41.90	2.50	0.20	0.40	0.10	0.14	0.85	-24.55	-41.76	-0.09	-1.18	0.05	1.14	-0.04	-0.04		
450	0	250	-28.34	-44.46	0.36	0.00	0.32	-29.20	-45.80	2.40	0.20	0.40	0.10	0.14	0.83	-28.37	-45.66	-0.03	-1.20	0.04	1.13	0.01	-0.07		
450	0	350	-32.11	-48.23	0.27	0.00	0.45	-33.00	-49.70	2.40	0.20	0.40	0.10	0.14	0.83	-32.17	-48.56	-0.06	-1.33	0.08	1.17	0.02	-0.16		
450	200	200	-30.56	-46.68	0.28	0.36	0.25	-31.60	-48.10	2.40	0.20	0.40	0.10	0.14	0.83	-30.77	-47.96	-0.21	-1.28	0.16	1.25	-0.04	-0.03		
450	200	-200	-30.56	-46.68	0.28	0.36	0.25	-31.60	-48.30	2.40	0.20	0.40	0.10	0.14	0.83	-30.77	-48.16	-0.21	-1.48	0.29	1.36	0.08	-0.10		
450	250	0	-30.13	-46.25	0.27	0.44	0.00	-31.10	-47.70	2.40	0.20	0.40	0.10	0.14	0.83	-30.27	-47.56	-0.14	-1.31	0.24	1.33	0.11	0.02		
450	300	300	-37.92	-54.04	0.04	0.52	0.38	-39.30	-56.10	2.40	0.20	0.40	0.10	0.14	0.83	-38.47	-55.96	-0.55	-1.92	0.34	1.43	-0.21	-0.49		
450	300	-300	-37.92	-54.04	0.04	0.52	0.38	-39.30	-56.10	2.40	0.20	0.40	0.10	0.14	0.83	-38.47	-55.96	-0.55	-1.92	0.53	1.62	-0.02	-0.30		
450	350	0	-35.26	-51.38	0.09	0.59	0.00	-36.50	-53.00	2.40	0.20	0.40	0.10	0.14	0.83	-35.67	-52.86	-0.41	-1.48	0.41	1.50	0.00	0.01		
																Std. dev:		0.19		0.31		0.14		0.20	
																Max:		0.17		0.82		0.37		0.37	
																Min:		-0.65		-2.02		-0.24		-0.52	
																Max-Min:		0.82		1.30		0.61		0.89	
																Average:		-0.16		-1.26		0.00		-0.01	

Ref. Loop 1 & 2, 180 deg			Calculated	Derivatives			Measured		Transmitting reference loop impedance (Z ₀)				Compensation		Compensated		Difference		Pos. and Match		Difference								
Positioning parameters			attenuation				attenuation		Reference loop number 1				factor		attenuation		measured-calculated		Correction		measured-corrected								
Height, z [mm]	Lateral y [mm]	Long. x [mm]	Tele-powering [dB]	Up-link [dB]	z-deviation [dB/cm]	y-deviation [dB/cm]	x-deviation [dB/cm]	(0) Tele-powering [dB]	(0) Up-link [dB]	(0) Tele-powering resistance [dB/cm]	(0) Tele-powering reactance [dB/cm]	(0) Up-link resistance [dB/cm]	(0) Up-link reactance [dB/cm]	Up-link [dB]	Tele-powering [dB]	Tele-powering [dB]	Up-link [dB]	Tele-powering [dB]	Up-link [dB]	Tele-powering [dB]	Up-link [dB]	Tele-powering [dB]	Up-link [dB]						
220	-200	0	-21.28	-37.40	0.12	1.14	0.00	-22.00	-38.60	2.50	0.20	0.40	0.10	0.14	0.85	-21.15	-38.46	0.13	-1.06	0.29	1.46	0.49	0.39						
220	-150	0	-16.58	-32.70	0.41	0.81	0.00	-17.40	-33.80	2.70	0.20	0.40	0.10	0.14	0.88	-16.52	-33.66	0.06	-0.98	0.12	1.21	0.18	0.25						
220	-150	200	-21.22	-37.34	0.26	0.86	0.48	-21.90	-38.50	2.50	0.20	0.40	0.10	0.14	0.85	-21.05	-38.36	0.17	-1.02	0.23	1.32	0.39	0.29						
220	-150	-200	-21.22	-37.34	0.26	0.86	0.48	-22.10	-38.60	2.50	0.20	0.40	0.10	0.14	0.85	-21.25	-38.46	-0.03	-1.12	0.26	1.35	0.22	0.22						
220	-100	-100	-14.52	-30.64	0.54	0.54	0.24	-15.50	-31.70	2.90	0.20	0.40	0.10	0.14	0.91	-14.59	-31.56	-0.07	-0.92	0.00	1.09	0.03	0.16						
220	0	250	-17.86	-33.98	0.53	0.00	0.60	-18.80	-35.10	2.60	0.20	0.40	0.10	0.14	0.86	-17.94	-34.96	-0.08	-0.98	-0.03	1.06	-0.11	0.09						
220	0	150	-13.37	-29.49	0.63	0.00	0.34	-14.30	-30.60	3.00	0.20	0.40	0.10	0.14	0.93	-13.37	-30.46	0.00	-0.97	-0.10	0.99	-0.10	0.01						
220	0	0	-10.85	-26.97	0.70	0.00	0.00	-11.90	-28.00	3.50	0.20	0.40	0.10	0.14	1.01	-10.89	-27.86	-0.04	-0.99	-0.15	0.94	-0.19	0.05						
220	0	-150	-13.37	-29.49	0.63	0.00	0.34	-14.30	-30.60	3.00	0.20	0.40	0.10	0.14	0.93	-13.37	-30.46	0.00	-0.97	-0.08	1.01	-0.08	0.03						
220	0	-250	-17.86	-33.98	0.53	0.00	0.60	-18.80	-35.20	2.60	0.20	0.40	0.10	0.14	0.86	-18.04	-35.06	-0.16	-1.08	0.00	1.09	-0.17	0.01						
220	100	-100	-14.52	-30.64	0.54	0.54	0.24	-15.50	-31.70	2.90	0.20	0.40	0.10	0.14	0.91	-14.59	-31.56	-0.07	-0.92	-0.04	1.05	-0.11	0.13						
220	100	100	-14.52	-30.64	0.54	0.54	0.24	-15.50	-31.70	2.90	0.20	0.40	0.10	0.14	0.91	-14.59	-31.56	-0.07	-0.92	-0.05	1.04	-0.12	0.11						
220	150	200	-21.22	-37.34	0.26	0.86	0.48	-22.30	-38.60	2.50	0.10	0.40	0.10	0.14	0.85	-21.45	-38.46	-0.23	-1.12	0.15	1.24	-0.08	0.12						
220	150	-200	-21.22	-37.34	0.26	0.86	0.48	-22.20	-38.60	2.50	0.10	0.40	0.10	0.14	0.85	-21.35	-38.46	-0.13	-1.12	0.18	1.27	0.05	0.15						
220	200	0	-16.58	-32.70	0.41	0.81	0.00	-17.50	-33.80	2.70	0.20	0.40	0.10	0.14	0.88	-16.62	-33.66	-0.04	-0.96	0.05	1.14	0.01	0.17						
220	200	0	-21.28	-37.40	0.12	1.14	0.00	-22.30	-38.60	2.50	0.10	0.40	0.10	0.14	0.85	-21.45	-38.46	-0.17	-1.06	0.26	1.35	0.09	0.29						
340	275	0	-29.23	-45.35	0.09	0.79	0.00	-30.40	-46.90	2.40	0.20	0.40	0.10	0.14	0.83	-29.57	-46.76	-0.34	-1.41	0.30	1.39	-0.04	-0.02						
340	225	225	-29.90	-46.02	0.13	0.66	0.39	-31.20	-47.60	2.40	0.20	0.40	0.10	0.14	0.83	-30.37	-47.46	-0.47	-1.44	0.26	1.35	-0.20	-0.09						
340	225	-225	-29.90	-46.02	0.13	0.66	0.39	-31.10	-47.70	2.40	0.10	0.40	0.10	0.14	0.83	-30.27	-47.56	-0.37	-1.54	0.29	1.39	-0.08	-0.16						
340	0	-275	-24.71	-40.83	0.40	0.46	0.25	-25.70	-42.60	2.40	0.20	0.40	0.10	0.14	0.83	-24.87	-40.76	-0.11	-1.39	0.25	1.39	-0.04	0.06						
340	0	0	-18.39	-34.51	0.55	0.00	0.00	-19.30	-35.60	2.60	0.20	0.40	0.10	0.14	0.86	-18.44	-35.46	-0.05	-0.95	-0.03	1.06	-0.06	0.11						
340	0	275	-24.71	-40.83	0.40	0.46	0.25	-25.70	-42.10	2.50	0.20	0.40	0.10	0.14	0.85	-24.85	-41.96	-0.14	-1.13	0.08	1.17	-0.07	0.03						
340	-225	225	-29.90	-46.02	0.13	0.66	0.39	-30.60	-47.50	2.40	0.20	0.40	0.10	0.14	0.83	-29.77	-47.36	-0.13	-1.34	0.32	1.41	0.46	0.07						
340	-225	-225	-29.90	-46.02	0.13	0.66	0.39	-30.90	-47.60	2.40	0.20	0.40	0.10	0.14	0.83	-30.07	-47.46	-0.17	-1.44	0.35	1.44	0.18	0.00						
340	-275	0	-29.23	-45.35	0.09	0.79	0.00	-30.10	-46.70	2.40	0.20	0.40	0.10	0.14	0.83	-29.57	-46.66	-0.11	-1.39	0.25	1.39	-0.04	0.06						
450	-300	0	-35.26	-51.38	0.09	0.59	0.00	-36.00	-53.10	2.40	0.20	0.40	0.10	0.14	0.83	-35.17	-52.96	0.08	-1.58	0.36	1.45	0.46	-0.13						
450	-300	300	-37.92	-54.04	0.04	0.52	0.38	-38.50	-56.00	2.40	0.20	0.40	0.10	0.14	0.83	-37.67	-55.86	-0.25	-1.82	0.39	1.49	0.64	-0.34						
450	-300	-300	-37.92	-54.04	0.04	0.52	0.38	-39.00	-56.00	2.40	0.20	0.40	0.10	0.14	0.83	-38.17	-55.86	-0.25	-1.82	0.41	1.50	0.16	-0.32						
450	-250	0	-30.13	-46.25	0.27	0.44	0.00	-30.90	-47.70	2.40	0.20	0.40	0.10	0.14	0.83	-30.07	-47.56	0.08	-1.31	0.21	1.30	0.27	-0.01						
450	-200	200	-30.56	-46.68	0.28	0.36	0.25	-31.30	-48.10	2.40	0.20	0.40	0.10	0.14	0.83	-30.47	-47.96	0.09	-1.28	0.19	1.28	0.28	0.00						
450	-200	-200	-30.56	-46.68	0.28	0.36	0.25	-31.50	-48.20	2.40	0.20	0.40	0.10	0.14	0.83	-30.67	-48.06	-0.11	-1.39	0.20	1.29	0.10	-0.08						
450	0	-350	-32.11	-48.23	0.27	0.00	0.45	-33.30	-49.80	2.40	0.20	0.40	0.10	0.14	0.83	-32.47	-49.76	-0.36	-1.53	0.21	1.30	-0.15	-0.23						
450	0	-250	-28.34	-44.46	0.36	0.00	0.32	-29.40	-46.00	2.40	0.20	0.40	0.10	0.14	0.83	-28.57	-45.86	-0.23	-1.40	0.13	1.22	-0.10	-0.18						
450	0	0	-24.46	-40.58	0.45	0.00	0.00	-25.40	-41.90	2.50	0.20	0.40	0.10	0.14	0.85	-24.55	-41.76	-0.09	-1.10	0.05	1.14	-0.04	-0.04						
450	0	250	-28.34	-44.46	0.36	0.00	0.32	-29.30	-45.80	2.40	0.20	0.40	0.10	0.14	0.83	-28.47	-45.66	-0.13	-1.20	0.11	1.20	-0.02	0.00						
450	0	350	-32.11	-48.23	0.27	0.00	0.45	-33.10	-49.60	2.40	0.20	0.40	0.10	0.14	0.83	-32.27	-49.66	-0.16	-1.43	0.10	1.27	0.02	-0.16						
450	200	200	-30.56	-46.68	0.28	0.36	0.25	-31.70	-48.20	2.40	0.20	0.40	0.10	0.14	0.83	-30.67	-48.06	-0.31	-1.39	0.16	1.25	-0.15	-0.13						
450	200	-200	-30.56	-46.68	0.28	0.36	0.25	-31.60	-48.10	2.40	0.20	0.40	0.10	0.14	0.83	-30.77	-48.06	-0.21	-1.39	0.18	1.27	-0.03	-0.11						
450	250	0	-30.13	-46.25	0.27	0.44	0.00	-31.20	-47.70	2.40	0.20	0.40	0.10	0.14	0.83	-30.37	-47.56	-0.24	-1.31	0.17	1.26	-0.06	-0.05						
450	300	300	-37.92	-54.04	0.04	0.52	0.38	-39.60	-58.10	2.40	0.20	0.40	0.10	0.14	0.83	-38.77	-55.86	-0.85	-1.92	0.34	1.43	0.51	-0.49						
450	300	-300	-37.92	-54.04	0.04	0.52	0.38	-39.40	-58.00	2.40	0.20	0.40	0.10	0.14	0.83	-38.57	-55.86	-0.65	-1.82	0.37	1.46	-0.28	-0.37						
450	350	0	-35.26	-51.38	0.09	0.59	0.00	-36.70	-53.00	2.40	0.20	0.40	0.10	0.14	0.83	-35.87	-52.86	-0.61	-1.48	0.31	1.40	0.30	-0.08						
			Difference in x-position [cm]			0.03												Std. dev			0.22			0.28					
			Difference in y-position [cm]			0.05															Max			0.25			-0.89		
			Difference in z-position [cm]			0.80															Min			-0.85			-1.92		
			B-factor, up-link			0.84			-1.50 dB												Max-Min			1.10			1.03		
			B-factor, tele-powering			0.95			-0.41 dB												Average			-0.14			-1.26		

Ref. Loop 3 & 1, 0 deg			Calculated	Derivatives			Measured		Transmitting reference loop impedance (Z ₀)				Compensation		Compensated		Difference		Pos. and Match		Difference		
Positioning parameters			attenuation				attenuation		Reference loop number 3				factor		attenuation		measured-calculated		Correction		measured-corrected		
Height, z [mm]	Lateral y [mm]	Long. x [mm]	Tele-powering [dB]	Up-link [dB]	z-deviation [dB/cm]	y-deviation [dB/cm]	x-deviation [dB/cm]	(0) Tele-powering [dB]	(0) Up-link [dB]	(0) Tele-powering resistance [dB/cm]	(0) Tele-powering reactance [dB/cm]	(0) Up-link resistance [dB/cm]	(0) Up-link reactance [dB/cm]	Up-link [dB]	Tele-powering [dB]	Tele-powering [dB]	Up-link [dB]	Tele-powering [dB]	Up-link [dB]	Tele-powering [dB]	Up-link [dB]	Tele-powering [dB]	Up-link [dB]
220	-200	0	-21.28	-37.40	0.12	1.14	0.00	-22.00	-38.60	2.50	0.10	0.40	0.10	0.14	0.85	-21.25	-38.46	0.03	-1.06	0.29	1.26	0.32	0.20
220	-150	0	-16.58	-32.70	0.41	0.81	0.00	-17.50	-33.80	2.70	0.10	0.40	0.10	0.14	0.88	-16.62	-33.66	-0.04	-0.96	0.04	1.01	0.00	0.05
220	-150	200	-21.22	-37.34	0.26	0.86	0.48	-22.20	-38.50	2.50	0.10	0.40	0.10	0.14	0.85	-21.35	-38.36	-0.13	-1.02	0.21	1.18	0.08	0.16
220	-150	-200	-21.22	-37.34	0.26	0.86	0.48	-22.00	-38.50	2.50	0.10	0.40	0.10	0.14	0.85	-21.15	-38.36	0.00	-1.02	0.15	1.12	0.22	0.10
220	-100	-100	-14.52	-30.64	0.54	0.54	0.24	-15.50	-31.70	2.90	0.20	0.40	0.10	0.14	0.91	-14.59	-31.56	-0.07	-0.92	-0.04	0.93	-0.10	0.01
220	0	250	-17.86	-33.98	0.53	0.00	0.60	-18.80	-35.10	2.60	0.20	0.40	0.10										

Ref. Loop 3 & 1, 180 deg			Calculated attenuation	Derivatives			Measured attenuation	Transmitting reference loop impedance (Z ₀)				Compensation factor		Compensated attenuation	Difference measured-calculated		Pos. and Match Correction		Difference measured-corrected										
Height, z [mm]	Lateral y [mm]	Long. x [mm]	Tele-powering [dB]	Up-link [dB]	z deviation [dB/cm]	y deviation [dB/cm]	x deviation [dB/cm]	(0) Tele-powering [dB]	(0) Up-link [dB]	(0) Tele-powering resistance [dB/cm]	(0) Tele-powering reactance [dB/cm]	(0) Up-link resistance [dB/cm]	(0) Up-link reactance [dB/cm]	Up-link [dB]	Tele-powering [dB]	Tele-powering [dB]	Up-link [dB]	Tele-powering [dB]	Up-link [dB]	Tele-powering [dB]	Up-link [dB]								
220	-200	0	-21.28	-37.40	0.12	1.14	0.00	-22.00	-38.50	2.50	0.20	0.40	0.10	0.14	0.85	-21.25	-38.30	0.03	-0.96	0.37	1.34	0.40	0.38						
220	-150	0	-16.58	-32.70	0.41	0.81	0.00	-17.40	-33.70	2.70	0.20	0.40	0.10	0.16	0.80	-16.50	-33.50	0.08	-0.86	0.10	1.07	0.16	0.21						
220	-150	200	-21.22	-37.34	0.26	0.86	0.48	-22.00	-38.40	2.50	0.20	0.40	0.10	0.14	0.85	-21.15	-38.20	0.07	-0.92	0.14	1.11	0.21	0.19						
220	-150	-200	-21.22	-37.34	0.26	0.86	0.48	-22.20	-38.50	2.50	0.10	0.40	0.10	0.14	0.85	-21.35	-38.30	-0.13	-1.02	0.34	1.31	0.21	0.29						
220	-100	-100	-14.52	-30.64	0.54	0.54	0.24	-15.50	-31.70	2.90	0.20	0.40	0.10	0.14	0.91	-14.48	-31.40	0.03	-0.92	-0.07	0.90	-0.03	0.08						
220	0	250	-17.86	-33.98	0.53	0.00	0.60	-18.80	-35.00	2.60	0.10	0.40	0.10	0.14	0.86	-17.94	-34.86	-0.08	-0.88	-0.12	0.85	-0.20	-0.03						
220	0	150	-13.37	-29.49	0.63	0.00	0.34	-14.30	-30.50	3.00	0.20	0.40	0.10	0.14	0.93	-13.37	-30.30	0.00	-0.87	-0.16	0.81	-0.16	-0.06						
220	0	0	-10.85	-26.97	0.70	0.00	0.00	-11.90	-27.90	3.50	0.20	0.40	0.10	0.14	1.01	-10.89	-27.76	-0.04	-0.79	-0.16	0.82	-0.19	0.02						
220	0	-150	-13.37	-29.49	0.63	0.00	0.34	-14.40	-30.60	3.00	0.20	0.40	0.10	0.14	0.93	-13.47	-30.36	-0.10	-0.87	-0.02	0.95	-0.12	-0.08						
220	0	-250	-17.87	-33.98	0.53	0.00	0.60	-18.90	-35.20	2.50	0.10	0.40	0.10	0.14	0.86	-18.04	-35.06	-0.18	-1.08	0.10	1.10	-0.04	0.02						
220	100	-100	-14.52	-30.64	0.54	0.54	0.24	-15.50	-31.70	2.90	0.20	0.40	0.10	0.14	0.91	-14.59	-31.56	-0.07	-0.92	0.06	1.03	-0.01	0.11						
220	100	100	-14.52	-30.64	0.54	0.54	0.24	-15.50	-31.60	2.90	0.20	0.40	0.10	0.14	0.91	-14.59	-31.46	-0.07	-0.82	-0.04	0.93	-0.11	0.11						
220	150	200	-21.22	-37.34	0.26	0.86	0.48	-22.20	-38.60	2.50	0.10	0.40	0.10	0.14	0.85	-21.35	-38.46	-0.13	-1.12	0.18	1.15	0.05	0.03						
220	150	-200	-21.22	-37.34	0.26	0.86	0.48	-22.30	-38.70	2.50	0.10	0.40	0.10	0.14	0.85	-21.45	-38.56	-0.23	-1.22	0.39	1.36	0.15	0.13						
220	200	0	-16.58	-32.70	0.41	0.81	0.00	-17.60	-33.80	2.70	0.10	0.40	0.10	0.14	0.88	-16.62	-33.66	-0.04	-0.85	0.14	1.11	0.10	0.15						
220	200	0	-21.28	-37.40	0.12	1.14	0.00	-22.30	-38.60	2.50	0.10	0.40	0.10	0.14	0.85	-21.45	-38.46	-0.17	-1.06	0.42	1.39	0.25	0.33						
340	275	0	-29.23	-45.35	0.09	0.79	0.00	-30.40	-46.90	2.40	0.10	0.40	0.10	0.14	0.83	-29.57	-46.76	-0.34	-1.41	0.44	1.41	0.11	-0.01						
340	225	225	-29.90	-46.02	0.13	0.66	0.39	-31.10	-47.60	2.40	0.20	0.40	0.10	0.14	0.83	-30.27	-47.46	-0.37	-1.44	0.32	1.29	0.05	-0.15						
340	225	-225	-29.90	-46.02	0.13	0.66	0.39	-31.20	-47.70	2.40	0.10	0.40	0.10	0.14	0.83	-30.37	-47.56	-0.47	-1.54	0.48	1.45	0.02	-0.09						
340	0	-275	-24.71	-40.83	0.40	0.25	0.46	-25.60	-47.00	2.40	0.20	0.40	0.10	0.14	0.83	-24.85	-40.72	-0.24	-1.20	0.20	1.20	0.01	-0.20						
340	0	0	-18.39	-34.51	0.55	0.00	0.00	-19.30	-40.00	2.60	0.20	0.40	0.10	0.14	0.86	-18.44	-34.40	-0.05	-0.95	-0.01	0.96	-0.06	0.01						
340	0	275	-24.71	-40.83	0.40	0.00	0.48	-25.70	-42.00	2.50	0.20	0.40	0.10	0.14	0.85	-24.85	-41.86	-0.14	-1.03	0.03	1.00	-0.11	-0.03						
340	-225	225	-29.90	-46.02	0.13	0.66	0.39	-30.90	-47.30	2.40	0.20	0.40	0.10	0.14	0.83	-30.07	-47.16	-0.17	-1.14	0.29	1.26	0.12	0.12						
340	-225	-225	-29.90	-46.02	0.13	0.66	0.39	-31.00	-47.50	2.40	0.20	0.40	0.10	0.14	0.83	-30.17	-47.26	-0.27	-1.34	0.45	1.42	0.18	0.08						
340	-275	0	-29.23	-45.35	0.09	0.79	0.00	-30.20	-46.80	2.40	0.20	0.40	0.10	0.14	0.83	-29.77	-47.06	-0.21	-1.18	0.18	1.15	0.03	-0.00						
450	-200	-200	-30.56	-46.68	0.28	0.36	0.25	-31.60	-48.10	2.40	0.20	0.40	0.10	0.14	0.83	-30.77	-47.86	-0.21	-1.18	0.18	1.15	0.03	-0.00						
450	-200	0	-35.26	-51.38	0.09	0.59	0.00	-36.40	-53.00	2.40	0.20	0.40	0.10	0.14	0.83	-35.57	-52.86	-0.31	-1.48	0.41	1.38	0.10	-0.10						
450	0	-350	-32.11	-48.23	0.27	0.00	0.45	-33.40	-49.90	2.40	0.10	0.40	0.10	0.14	0.83	-32.57	-48.76	-0.46	-1.53	0.35	1.32	-0.11	-0.21						
450	0	-250	-28.34	-44.46	0.36	0.00	0.32	-29.50	-45.90	2.40	0.20	0.40	0.10	0.14	0.83	-28.67	-45.76	-0.33	-1.30	0.24	1.21	-0.09	-0.10						
450	0	0	-24.46	-40.58	0.45	0.00	0.00	-25.40	-41.80	2.50	0.20	0.40	0.10	0.14	0.85	-24.66	-40.99	-0.08	-0.98	0.05	1.01	-0.01	-0.03						
450	0	250	-28.34	-44.46	0.36	0.00	0.32	-29.30	-45.70	2.40	0.20	0.40	0.10	0.14	0.83	-28.47	-45.56	-0.13	-1.10	0.10	1.07	-0.03	-0.03						
450	0	350	-32.11	-48.23	0.27	0.00	0.45	-33.20	-49.70	2.40	0.20	0.40	0.10	0.14	0.83	-32.27	-49.16	-0.26	-1.13	0.10	1.10	-0.10	-0.20						
450	200	200	-30.56	-46.68	0.28	0.36	0.25	-31.70	-48.10	2.40	0.20	0.40	0.10	0.14	0.83	-30.67	-47.96	-0.31	-1.28	0.20	1.17	-0.11	-0.11						
450	200	-200	-30.56	-46.68	0.28	0.36	0.25	-31.70	-48.20	2.40	0.20	0.40	0.10	0.14	0.83	-30.67	-48.06	-0.31	-1.38	0.31	1.28	0.00	-0.11						
450	250	0	-30.13	-46.25	0.27	0.44	0.00	-31.20	-47.70	2.40	0.20	0.40	0.10	0.14	0.83	-30.37	-47.56	-0.24	-1.31	0.26	1.23	0.03	-0.08						
450	300	300	-37.92	-54.04	0.04	0.52	0.38	-39.40	-55.90	2.40	0.20	0.40	0.10	0.14	0.83	-38.57	-55.76	-0.65	-1.72	0.41	1.38	0.24	-0.35						
450	300	-300	-37.92	-54.04	0.04	0.52	0.38	-39.60	-56.30	2.40	0.10	0.40	0.10	0.14	0.83	-38.77	-55.76	-0.65	-1.72	0.46	1.53	-0.28	-0.18						
450	350	0	-35.26	-51.38	0.09	0.59	0.00	-36.60	-53.10	2.40	0.20	0.40	0.10	0.14	0.83	-35.77	-52.86	-0.51	-1.58	0.44	1.47	0.07	-0.17						
			Difference in x-position [cm]			0.21									Std. dev.			0.20			0.28			0.15			0.18		
			Difference in y-position [cm]			-0.03									Max.			0.07			-0.79			0.40			0.38		
			Difference in z-position [cm]			0.55									Min.			-0.85			-1.92			-0.28			-0.47		
			B-factor, up-link			0.84			-1.48 dB						Max-Min.			0.92			1.13			0.68			0.85		
			B-factor, tele-powering			0.94			-0.51 dB						Average			-0.22			-1.20			0.00			-0.01		

Ref. Loop 2 & 3, 0 deg			Calculated attenuation	Derivatives			Measured attenuation	Transmitting reference loop impedance (Z ₀)				Compensation factor		Compensated attenuation	Difference measured-calculated		Pos. and Match Correction		Difference measured-corrected				
Height, z [mm]	Lateral y [mm]	Long. x [mm]	Tele-powering [dB]	Up-link [dB]	z deviation [dB/cm]	y deviation [dB/cm]	x deviation [dB/cm]	(0) Tele-powering [dB]	(0) Up-link [dB]	(0) Tele-powering resistance [dB/cm]	(0) Tele-powering reactance [dB/cm]	(0) Up-link resistance [dB/cm]	(0) Up-link reactance [dB/cm]	Up-link [dB]	Tele-powering [dB]	Tele-powering [dB]	Up-link [dB]	Tele-powering [dB]	Up-link [dB]	Tele-powering [dB]	Up-link [dB]		
220	-200	0	-21.28	-37.40	0.12	1.14	0.00	-22.00	-38.50	2.60	0.00	0.40	-0.10	0.16	0.86	-21.14	-38.34	0.14	-0.94	0.25	1.21	0.39	0.26
220	-150	0	-16.58	-32.70	0.41	0.81	0.00	-17.40	-33.70	2.60	0.00	0.40	-0.10	0.16	0.80	-16.50	-33.54	0.08	-0.84	0.02	0.98	0.09	0.13
220	-150	200	-21.22	-37.34	0.26	0.86	0.48	-22.20	-38.60	2.50	0.00	0.40	-0.10	0.16	0.85	-21.35	-38.44	-0.13	-1.10	0.24	1.20	0.11	0.09
220	-150	-200	-21.22	-37.34	0.26	0.86	0.48	-22.10	-38.50	2.60	0.00	0.40	-0.10	0.16	0.86	-21.35	-38.14	-0.28	-0.85	0.07	1.03	0.36	0.22
220	-100	-100	-14.52	-30.64	0.54	0.54	0.24	-15.40	-31.60	2.90	0.00	0.40	-0.10	0.16	0.91	-14.48	-31.44	0.03	-0.81	-0.11	0.85	-0.08	0.04
220	-100	100	-14.52	-30.64	0.54	0.54	0.24	-15.50	-31.70	2.90	0.00	0.40	-0.10	0.16	0.91	-14.59	-31.54	-0.07	-0.90	-0.03	0.93	-0.09	0.03
220	0	250	-17.86	-33.98	0.53	0.00	0.60	-19.00	-35.20	2.60	0.00	0.40	-0.10	0.16	0.86	-18.14	-35.04	-0.28	-1.06	0.12	1.08	-0.15	0.02
220	0	150	-13.37	-29.49	0.63	0.00	0.34	-14.50	-30.60	3.00	0.00	0.40	-0.10	0.16	0.93	-13.57	-30.44	-0.20	-0.95	-0.02	0.94	-0.22	-0.01
220	0	0	-10.85	-26.97	0.70	0.00	0.00	-11.90	-28.00	3.50	0.10	0.40	-0.10	0.16	1.01	-10.89	-27.84	-0.04	-0.87	-0.15	0.82	-0.18	-0.06
220	0	-150	-13.37	-29.49	0.63	0.00	0.34	-14.60	-30.70	3.10	0.00	0.40	-0.10	0.16	0.95	-13.55	-30.34	-0.23	-1.10	0.31	1.27	0.07	0.16
220	0	-250	-17.86	-33.98	0.53	0.00	0.60	-18.70	-35.00	2.70	0.00	0.40	-0.10	0.16									

B3 Test Antenna

B3.1 Size of the Test Antenna

The size of the Test Antenna loop shall be 200 mm × 200 mm for the Tele-powering signal. The size of the Up-link Test Antenna loop shall be 40 mm × 40 mm. The two loops shall be in the same plane and have the same geometrical centre to within ±2 mm. A shielding plate shall be positioned parallel to the loops, and at 400 mm distance from the centre of the loops. The size of the shielding plate shall be 600 mm × 600 mm.

The Tele-powering loop of the Test Antenna shall be tuned with serial capacitors to the actual frequency band. The loop impedance for the Up-link loop shall be high enough at the Tele-powering frequency band so that the field generated from this not intended current is negligible. Vice versa, the loop impedance for the Tele-powering loop shall be high enough at the Up-link frequency band so that the induced voltage from the Tele-powering loop is negligible.

The cable to the Test Antenna shall be of double shielded low loss type (e.g., RG 214). Furthermore, the cable shall be “de-bugged” using suitable ferrite clamps evenly spaced along the cable at distances of less than 70 cm.

B3.2 Field Requirements

The E-field rejection shall be more than 25 dB.

The Test Antenna shall be able to generate an H-field that gives more than 20 nVs in the Standard Size Reference Loop, and more than 7.5 nVs in the Reduced Size Reference Loop. This shall be valid when the Test Antenna is positioned anywhere within the Main Lobe Zone defined by UNISIG SUBSET-036.

B3.3 Impedance

The nominal source impedance for the Tele-powering loop is 50 Ω. The input impedance of the Tele-powering loop is to be defined by the supplier.

The nominal load impedance for the Up-link loop is 50 Ω. The source impedance of the Up-link loop is to be defined by the supplier.

B4 Activation Antenna

B4.1 Size of the Activation Antenna

The size of the Activation Antenna loop shall be 200 mm x 200 mm for the Tele-powering signal.

The Activation Antenna shall be tuned with serial capacitors to the actual frequency band. The loop impedance shall be high enough at the Up-link frequency band so that the field generated from this not intended current is negligible compared to the current in the Balise under test.

The cable to the Activation Antenna shall be of double shielded low loss type (e.g., RG 214). Furthermore, the cable shall be “de-bugged” using suitable ferrite clamps evenly spaced along the cable at distances of less than 70 cm.

B4.2 Field Requirements

The E-field rejection shall be more than 25 dB.

The Activation Antenna shall be able to generate an H-field that gives more than 150 nVs in the Standard Size Reference Loop, and more than 60 nVs in the Reduced Size Reference Loop. This shall be valid when the Activation Antenna is positioned 220 mm above the Reference Loop, and at the same time having a maximum longitudinal deviation of up to 250 mm relative to the Reference Loop. The Reference Area shall be parallel to the X-axis, and the lateral deviation shall be zero as defined by UNISIG SUBSET-036.

B4.3 Impedance

The nominal source impedance for the equipment to be connected to the Activation Antenna is 50 Ω . The input impedance of the loop is to be defined by the supplier.

B5 Conditions to be tested

B5.1 General

In general, when stating that something is related to the Reference Loop in the following sub-clauses, it also applies to the Balise and vice versa (if a specific test includes a Balise rather than a Reference Loop).

This sub-clause includes all different debris and metallic object cases defined by UNISIG SUBSET-036. However, in the specific tests defined by this specification, a relevant selection might apply (i.e., only a few cases are judged being relevant for test purposes).

B5.2 Debris

B5.2.1 General

The design of the Debris Box, and the utilisation, is according to Figure 53 and Figure 54 below. The size of the Debris Box is 1220 mm × 950 mm (X-direction × Y-direction).

B5.2.2 Liquid Debris

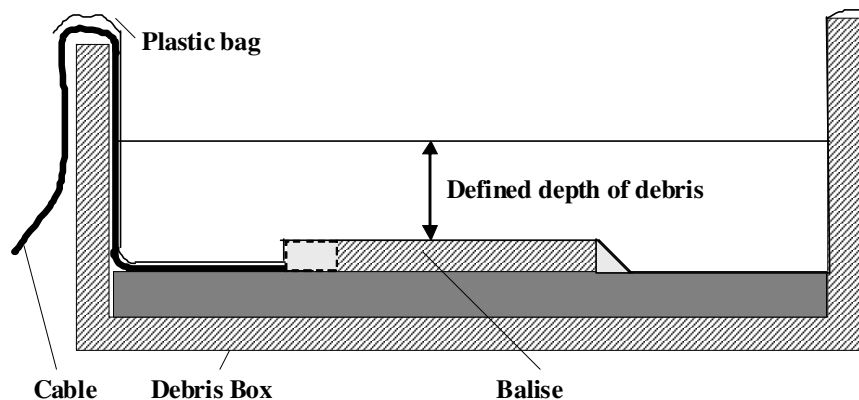

Figure 53: Application of liquid debris

There are two shaded areas in Figure 53 above, one to the left of the Balise (rectangular shape) and one to the right of the Balise (triangular shape). These are areas with material constituting free air conditions (or simply air). The rectangular area to the left of the Balise is the volume where the balun is positioned during calibrations with the Reference Loops. To ensure that the situation is not changed when real Balises are tested, this volume should constitute “free air conditions” also during Balise testing. The triangular area to the right of the Balise represents the unavoidable gap occurring when applying the plastic bag over the Balise. In order to achieve reproducibility, the plastic bag shall meet the foundation (exemplified by sand in the figure) at 45° angle.

Furthermore, in order to practically cope with irregular Balise surfaces, and to allow the use of a plastic bag with sufficient strength/thickness, it is allowed that the distance between the bottom of the debris layer and the lowest point of the top surface of the Balise (excluding fixation holes) is maximum 2 mm. It is also allowed that the plastic bag is not firmly attached to the edges of the debris box.

B5.2.3 Non-liquid Debris

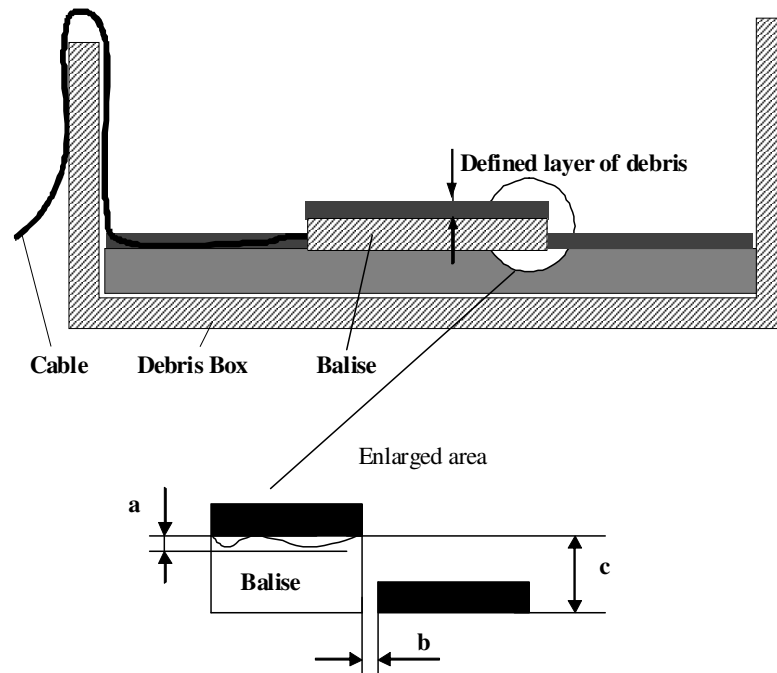

Figure 54: Application of non-liquid debris

The maximum distance between the bottom of the debris layer and the lowest point of the top surface of the Balise (excluding fixation holes) is the distance a in Figure 54. This distance shall be less than 2 mm for debris Class B, and less than 5 mm for debris Class A. Provided that this is fulfilled, the debris material may be housed in specific boxes of a material constituting free air conditions.

The maximum gap between the Balise and debris layer beside the Balise is the distance b in Figure 54. This distance shall not exceed 2 mm. Provided that this is fulfilled, the debris material may be housed in specific boxes of a material constituting free air conditions.

The distance between the bottom of the debris layer on top of the Balise and the bottom of the debris layer beside the Balise is the distance c in Figure 54. This distance shall be 70 mm for debris Class B and 110 mm for debris Class A.”

The debris layer on top of the Balise shall be larger than the Balise/Reference Loop top surface with a tolerance of less than 2 mm.

The debris layer beside the Balise shall end less than 100 mm from the edge of the debris box.

B5.2.4 Reference Loop and Balise

B5.2.4.1 Salt Water

Salt water with 0.1 % NaCl concentration shall be used.

Two test cases apply, 100 mm salt water depth above the top surface of the Reference Loop for debris Class A, and 10 mm for debris Class B. The volume underneath the Reference Loop shall be filled with a material constituting free air conditions.

B5.2.4.2 Clear Water

Two test cases apply, 200 mm clear water depth above the top surface of the Reference Loop for debris Class A, and 100 mm for debris Class B. The volume underneath the Reference Loop shall be filled with a material constituting free air conditions.

B5.2.4.3 Iron Ore (Magnetite)

Two test cases apply, a 20 mm thick layer of iron ore (Magnetite) on top of the Reference Loop for debris Class A, and 2 mm for debris Class B. The volume underneath the Reference Loop shall be filled with a material constituting free air conditions. The following details apply to this debris condition:

Contents of Fe ₃ O ₄ :	92.5 % to 97.5 %
Contents of Fe (enriched material):	less than 71 %
Moisture:	less than 4 %
Bulk Density:	3.2·10 ³ kg/m ³

B5.2.4.4 Iron Ore (Hematite)

A 20 mm thick layer of iron ore (Hematite) on top of the Reference Loop is applicable for both debris Class A and debris Class B. The volume underneath the Reference Loop shall be filled with a material constituting free air conditions. The following details apply to this debris condition:

Contents of Fe ₂ O ₃ :	90 % to 95 %
Contents of Fe ₃ O ₄ :	negligible
Contents of Fe (enriched material):	less than 68 %
Moisture:	less than 4 %
Bulk Density:	2.7·10 ³ kg/m ³

B5.2.4.5 Fresh Snow

Snow with a depth of 300 mm on top of the Reference Loop is applicable for both debris Class A and debris Class B. The temperature of the fresh snow shall be approximately 0 °C. Artificially created (using conventional methods) snow is acceptable. The volume underneath the Reference Loop shall be filled with a material constituting free air conditions.

B5.2.4.6 Wet Snow

Snow with a depth of 300 mm on top of the Reference Loop is applicable for both debris Class A and debris Class B. The temperature of the wet snow shall be approximately 0 °C, and the water contents shall be 20 % by volume. Artificially created (using conventional methods) snow is acceptable. When creating wet snow, fresh snow with a temperature of 0 °C shall be mixed with clear water also having a temperature of 0 °C (20 % by volume of water). The volume underneath the Reference Loop shall be filled with a material constituting free air conditions.

B5.2.4.7 Ice

Ice with a depth of 100 mm on top of the Reference Loop is applicable for both debris Class A and debris Class B. The ice shall not include pores other than those normally present when freezing water (starting from a water temperature of 20 °C) and caused by the gas present in the water. The ice shall be made from clear water. The volume underneath the Reference Loop shall be filled with a material constituting free air conditions.

B5.2.4.8 Ballast

Ballast with a depth of 100 mm on top of the Reference Loop is applicable for both debris Class A and debris Class B. The ballast shall be crushed stone free from iron that is normally present in Railway environment. The volume underneath the Reference Loop shall be filled with a material constituting free air conditions.

B5.2.4.9 Dry Sand

Sand with a depth of 20 mm on top of the Reference Loop is applicable for both debris Class A and debris Class B. The sand shall be dry and free from iron. The volume underneath the Reference Loop shall be filled with a material constituting free air conditions.

B5.2.4.10 Wet Sand

Sand with a depth of 20 mm on top of the Reference Loop is applicable for both debris Class A and debris Class B. The sand shall be free from iron, and the water contents shall be 20 % by volume (clear water). The volume underneath the Reference Loop shall be filled with a material constituting free air conditions.

B5.2.4.11 Mud without Salt Water

A 50 mm thick layer of mud on top of the Reference Loop is applicable for both debris Class A and debris Class B. The mud shall be free from iron, the water contents shall be 20 % by volume (clear water), and the mud shall be of terra-cotta type. The volume underneath the Reference Loop shall be filled with a material constituting free air conditions.

B5.2.4.12 Mud with Salt Water

Two test cases apply, a 50 mm thick layer of salted mud on top of the Reference Loop for debris Class A, and 10 mm for debris Class B. The mud shall be free from iron, the water contents shall be 20 % by volume, the salt concentration (NaCl) of the water shall be 0.5 % by weight, and the mud shall be of terra-cotta type. The volume underneath the Reference Loop shall be filled with a material constituting free air conditions.

B5.2.4.13 Iron Dust

A 10 mm thick layer of iron dust on top of the Reference Loop is applicable for both debris Class A and debris Class B. The iron dust (or braking dust) is a non-conductive mixture of grease and iron oxide, which is normally encountered in Railway environment. The volume underneath the Reference Loop shall be filled with a material constituting free air conditions.

B5.2.4.14 Coal Dust

A 10 mm thick layer of coal dust on top of the Reference Loop is applicable for both debris Class A and debris Class B. The coal dust shall include approximately 8 % of sulphur, and be of the type normally present in the nature (used for heating in some regions). The volume underneath the Reference Loop shall be filled with a material constituting free air conditions.

B5.2.4.15 Oil and Grease

A 50 mm thick layer of grease or depth of oil on top of the Reference Loop is applicable for both debris Class A and debris Class B. The grease shall be of ordinary ball bearing grease type, and the oil shall be standard mineral oil used for lubrication of engines. The volume underneath the Reference Loop shall be filled with a material constituting free air conditions.

B5.2.5 Antenna

B5.2.5.1 Ice

Testing shall be performed with a layer of ice applied at the bottom of the Antenna Unit having a thickness of minimum 10 mm and maximum down to top of the Balise. The ice shall not include pores other than those normally present when freezing water (starting from a water temperature of 20 °C) and caused by the gas present in the water. The ice shall be made from clear water. The actual thickness is to be defined by the supplier of the Antenna.

B5.2.5.2 Fresh Snow

Testing shall be performed with a layer of fresh snow applied at the bottom of the Antenna Unit having a thickness of minimum 20 mm and maximum down to top of the Balise. The temperature of the fresh snow shall be approximately 0 °C. Artificially created (using conventional methods) snow is acceptable. The actual thickness is to be defined by the supplier of the Antenna.

B5.2.5.3 Wet Snow

Testing shall be performed with a layer of wet snow applied at the bottom of the Antenna Unit having a thickness of minimum 10 mm and maximum down to top of the Balise. The temperature of the wet snow shall be approximately 0 °C, and the water contents shall be 20 % by volume. Artificially created (using conventional methods) snow is acceptable. When creating wet snow, fresh snow with a temperature of 0 °C shall be mixed with clear water also having a temperature of 0 °C (20 % by volume of water). The actual thickness is to be defined by the supplier of the Antenna.

B5.2.5.4 Mud without Salt Water

Testing shall be performed with a layer of mud applied at the bottom of the Antenna Unit having a thickness of minimum 10 mm and maximum of 50 mm. The mud shall be free from iron, the water contents shall be 20 % by volume (clear water), and the mud shall be of terra-cotta type. The actual thickness is to be defined by the supplier of the Antenna.

B5.2.5.5 Mud with Salt Water

Testing shall be performed with a layer of mud applied at the bottom of the Antenna Unit having a thickness of maximum of 50 mm. The mud shall be free from iron, the water contents shall be 20 % by volume, the salt concentration (NaCl) of the water shall be 0.5 % by weight, and the mud shall be of terra-cotta type. The actual thickness is to be defined by the supplier of the Antenna.

B5.2.5.6 Iron Ore (Magnetite)

Testing shall be performed with a layer of Magnetite applied at the bottom of the Antenna Unit having a thickness of maximum of 5 mm. The actual thickness is to be defined by the supplier of the Antenna. More details on the material are found in sub-clause B5.2.4.3 on page 193.

B5.2.5.7 Iron Ore (Hematite)

Testing shall be performed with a layer of Hematite applied at the bottom of the Antenna Unit having a thickness of maximum of 5 mm. The actual thickness is to be defined by the supplier of the Antenna. More details on the material are found in sub-clause B5.2.4.4 on page 193.

B5.2.5.8 Iron Dust

Testing shall be performed with a layer of iron dust applied at the bottom of the Antenna Unit having a thickness of minimum 2 mm, and maximum of 5 mm. The iron dust (or braking dust) is a non-conductive mixture of grease and iron oxide, which is normally encountered in Railway environment. The actual thickness is to be defined by the supplier of the Antenna.

B5.2.5.9 Coal Dust

Testing shall be performed with a layer of coal dust applied at the bottom of the Antenna Unit having a thickness of maximum of 5 mm. The coal dust shall include approximately 8 % of sulphur, and be of the type normally present in the nature (used for heating in some regions). The actual thickness is to be defined by the supplier of the Antenna.

B5.2.5.10 Oil and Grease

Testing shall be performed with a layer of oil or grease applied at the bottom of the Antenna Unit having a thickness of minimum 2 mm, and maximum of 20 mm. The grease shall be of ordinary ball bearing grease type, and the oil shall be standard mineral oil used for lubrication of engines. The actual thickness is to be defined by the supplier of the Antenna.

B5.3 Metallic Objects

B5.3.1 Iron Bars outside the metallic free volume of the Balise

The configuration according to Figure 55 below applies.

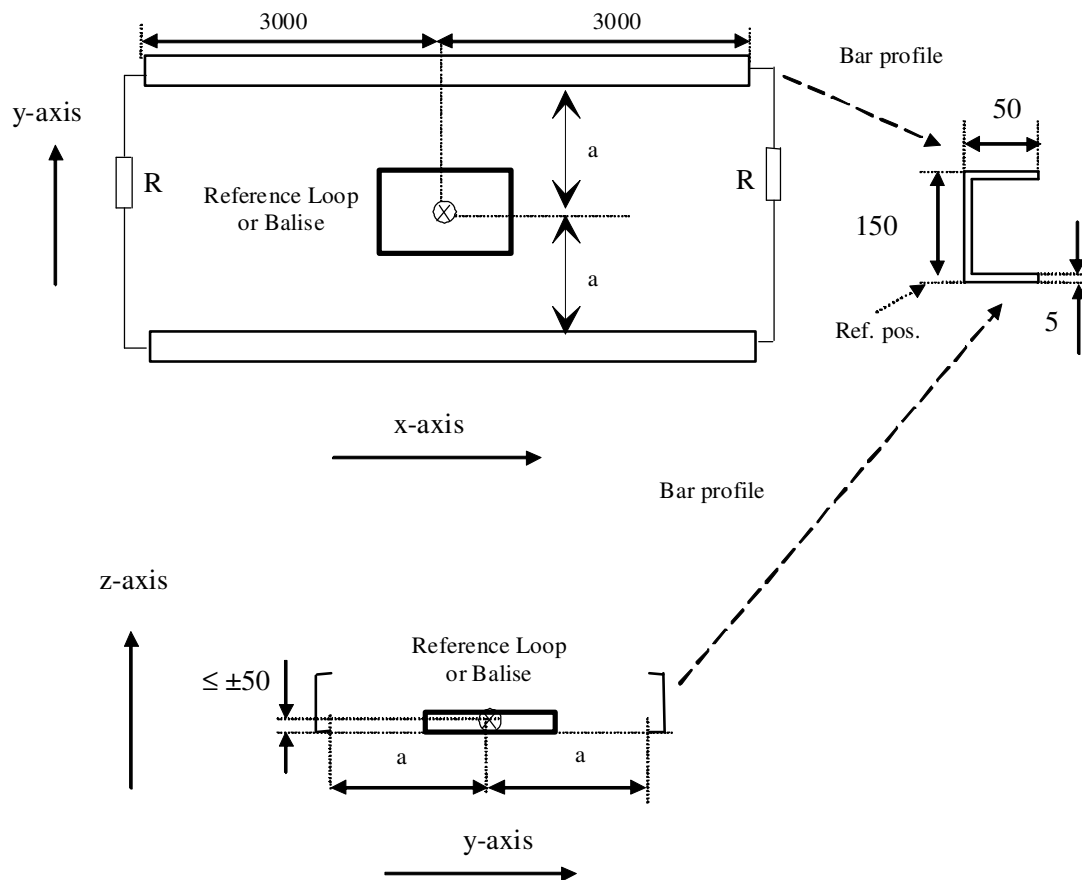

Figure 55: Iron bars close to the Reference Loop

The resistance 'R' shall be 200 Ω .

The distance 'a' shall be 400 mm for the Standard Size Reference Loop, 315 mm for the longitudinally mounted Reduced Size Reference Loop, and 410 mm for the transversally mounted Reduced Size Reference Loop.

B5.3.2 Guard Rails

The configuration according to Figure 56 below applies.

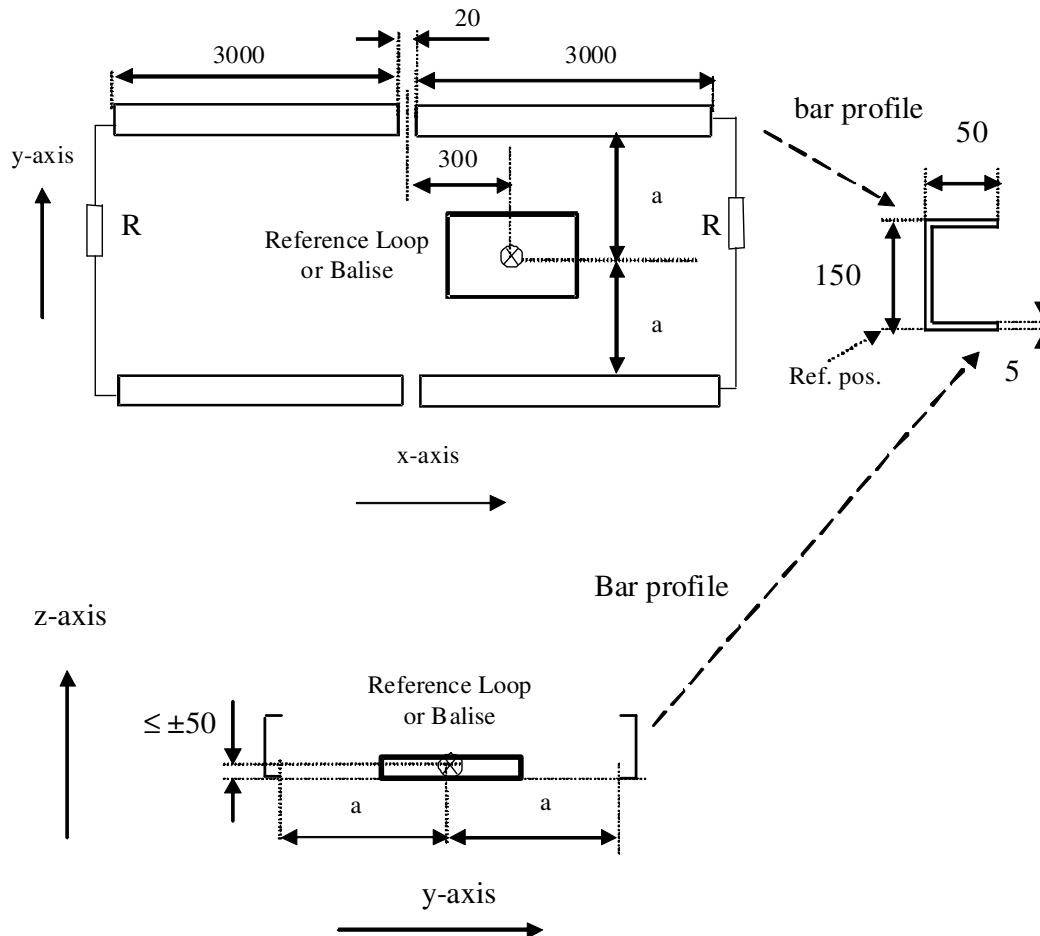

Figure 56: Guard Rails close to the Reference Loop

The resistance 'R' shall be 200 Ω .

The distance 'a' shall be 300 mm for the Standard Size Reference Loop, 320 mm for the transversally mounted Reduced Size Reference Loop, and 220 mm for the longitudinally mounted Reduced Size Reference Loop.

B5.3.3 Metallic Plane underneath the Balise

The configuration according to Figure 57 below applies.

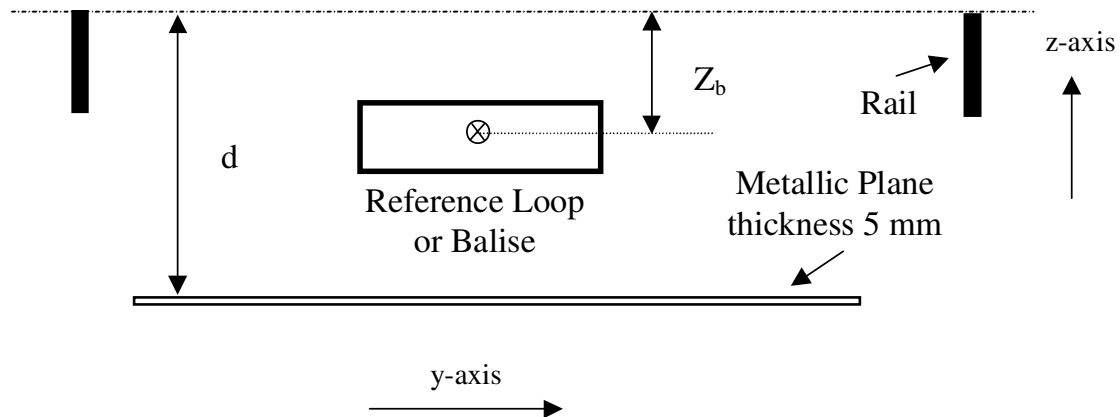

Figure 57: Metallic plane underneath the Reference Loop

The metallic plane shall be centred with respect to the Reference Loop and in a plane parallel to the top of Rails. The size along the x-axis shall be 1200 mm, and the size along the y-axis shall be 900 mm.

The following test cases shall be performed:

Size	Case	d [mm]	Zb [mm]
Standard	1	292	152
Standard	2	420	210
Standard	3	203	103
Reduced	1	283	143
Reduced	2	403	193
Reduced	3	193	103

The Rails are not part of the test set-up. They simply serve as height references.

B5.3.4 Steel Sleepers

This condition is optional, and applies only to products intended to be used during such conditions.

The configuration according to Figure 58 below applies.

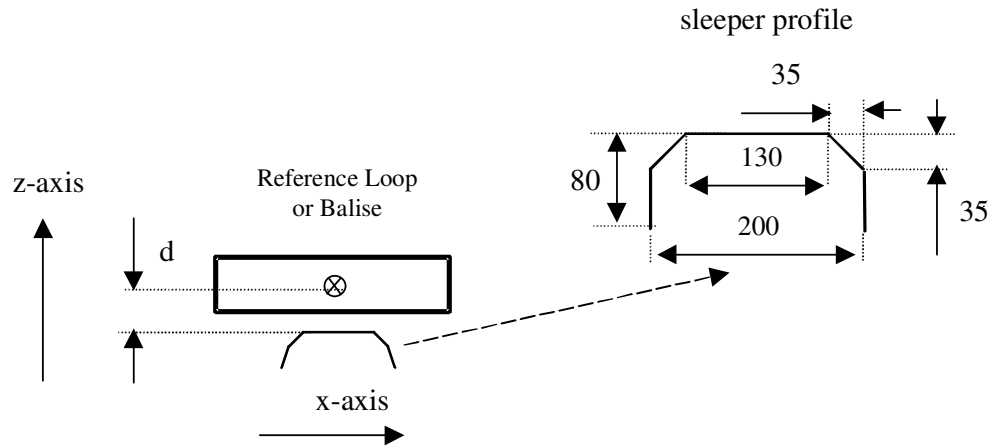

Figure 58: Steel sleeper underneath the Reference Loop

The steel sleeper shall be centred with respect to the Reference Loop. The size along the y-axis shall be 2000 mm.

The distance d is 45 mm for a Standard Size Reference Loop, and 60 mm for a Reduced Size Reference Loop.

B5.3.5 Other Sleepers

The configuration according to Figure 59 below applies.

Even non-conductive sleepers may include metallic mounting assemblies. However, the total area of such assemblies must be limited. For test purposes, the assemblies should be placed directly underneath the Reference Loop.

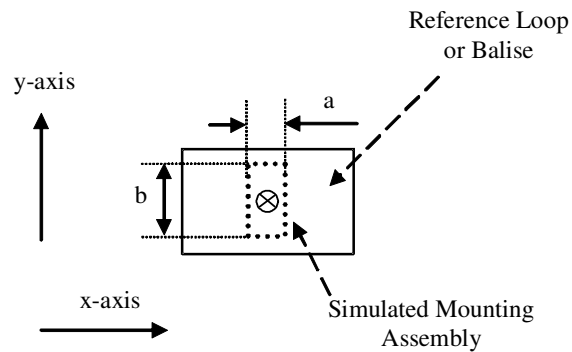

Figure 59: Mounting assemblies underneath the Reference Loop

The mounting assemblies should be simulated using metallic plates, centred with respect to the Reference Loop, and of the following dimensions for the respective Reference Loop size:

Size	a [mm]	b [mm]
Standard	100	300
Reduced	70	200

The thickness of the metallic plates shall be 2 mm.

For specific Balises, the test case may be modified, and shall be in accordance with the supplier's specification.

B5.3.6 Loop Cable

See sub-clauses 4.2.5.5 on page 62 and 5.2.10.3 on page 151. See also Annex J on page 333.

B5.3.7 Metallic objects outside the metal free volume of the Antenna Unit

Two different conditions apply. The first is a “box concept” with elongated openings in the corners (simulating equipment boxes surrounding the Antenna), and the second is a homogenous metal plate with an aperture for the Antenna. See Figure 60 and Figure 61 below.

Test Case 1:

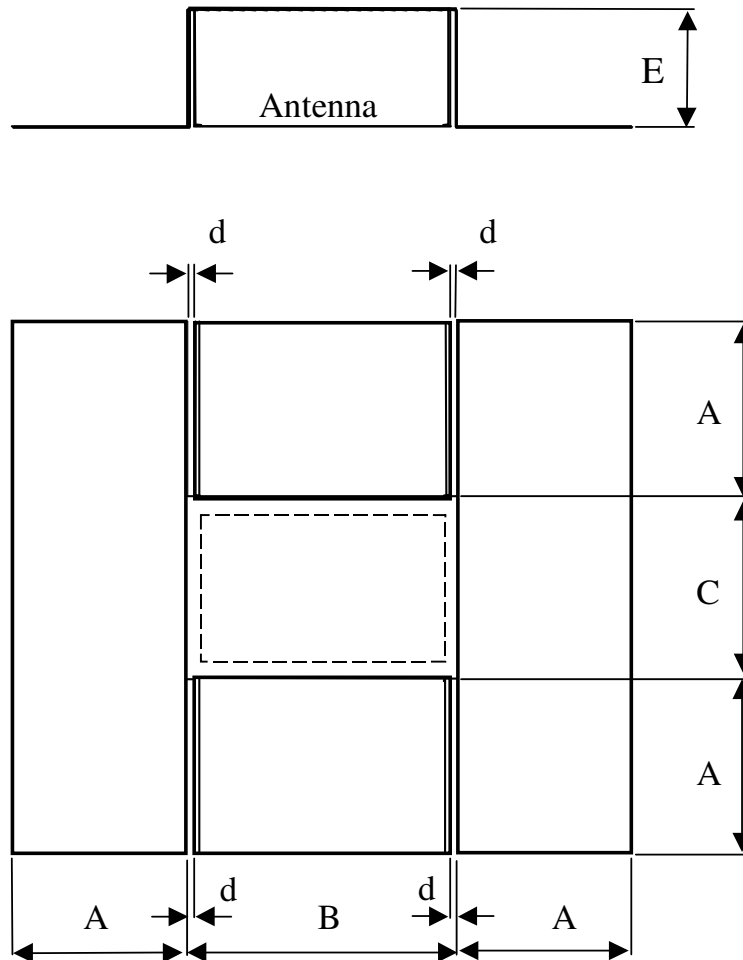

Figure 60: Metallic box around the Antenna

The thickness of the metallic plates should be at least 2 mm.

The distance ‘d’ is to be defined by the supplier of the Antenna and refers to the cuts in the metallic box.

The distance ‘A’ is 300 mm, the distances ‘B’ and ‘C’ shall be according to the suppliers specification, and the distance ‘E’ is the Antenna height.

Test Case 2:

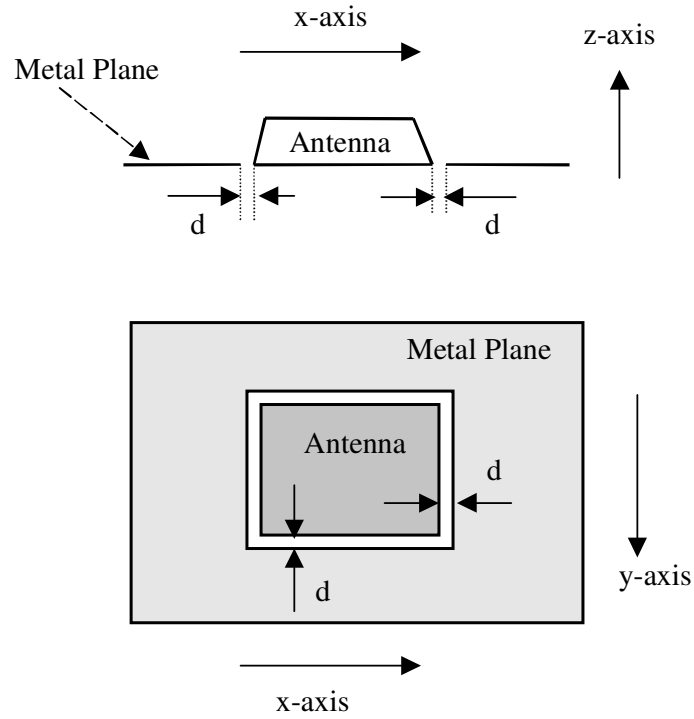

Figure 61: Metallic plate around the Antenna

The thickness of the metal plate should be at least 2 mm, and the outer dimension at least 1000 mm \times 1000 mm.

The distance 'd' is to be defined by the supplier of the Antenna.

B5.3.8 Metallic Masses in the Track

The configuration according to Figure 62 below applies.

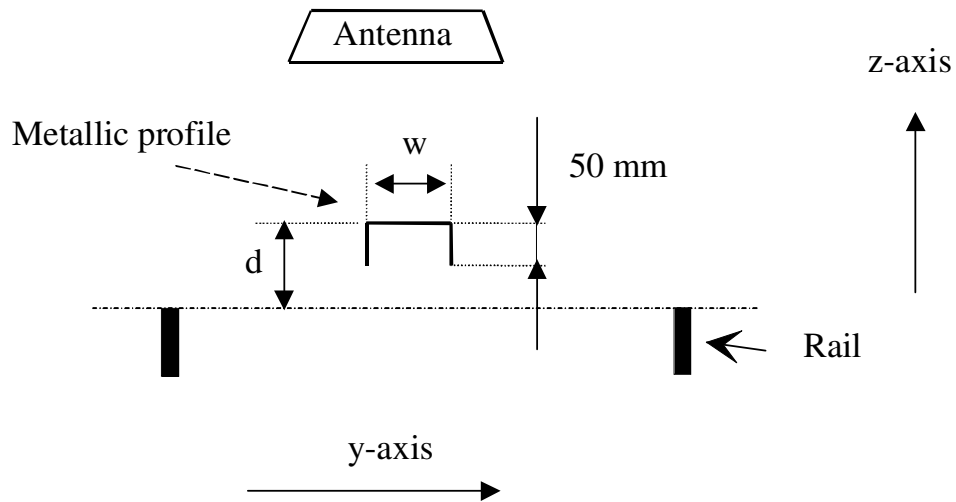

Figure 62: Metal masses in the Track

The metallic profile shall have a thickness of at least 2 mm, and a length of 1200 mm.

The following basic test cases apply:

Test case	w [mm]	d [mm]
1	120	92
2	200	50
3	800	0

The Rails are not part of the test set-up. They simply serve as height references.

Annex C (Normative), Measurement Points

C1 Geometrical Test Points Main Lobe Zone

The following geometrical test points apply (relative distances between the Balise / Reference Loop and the Antenna):

Z [mm]	Y [mm]	X [mm]	Z [mm]	Y [mm]	X [mm]
220	-200	0	460	-350	0
220	-150	0	460	-300	300
220	-150	200	460	-300	-300
220	-150	-200	460	-250	0
220	-100	-100	460	-200	200
220	-100	100	460	-200	-200
220	0	250	460	0	-350
220	0	150	460	0	-250
220	0	0	460	0	0
220	0	-150	460	0	250
220	0	-250	460	0	350
220	100	-100	460	200	200
220	100	100	460	200	-200
220	150	200	460	250	0
220	150	-200	460	300	300
220	150	0	460	300	-300
220	200	0	460	350	0
340	275	0			
340	225	225			
340	225	-225			
340	0	-275			
340	0	0			
340	0	275			
340	-225	225			
340	-225	-225			
340	-275	0			

Table 30: Geometrical Test Points within Main Lobe Zone

C2 Geometrical Test Points Side Lobe Zone

The following geometrical test points apply (relative distances between the Balise / Reference Loop and the Antenna):

Z [mm]	Y [mm]	X [mm]	Z [mm]	Y [mm]	X [mm]	Z [mm]	Y [mm]	X [mm]	Z [mm]	Y [mm]	X [mm]
220	0	200	220	0	-200	220	150	0	220	-150	0
220	0	250	220	0	-250	220	200	0	220	-200	0
220	0	300	220	0	-300	220	250	0	220	-250	0
220	0	350	220	0	-350	220	300	0	220	-300	0
220	0	400	220	0	-400	220	350	0	220	-350	0
220	0	450	220	0	-450	220	400	0	220	-400	0
220	0	500	220	0	-500	220	450	0	220	-450	0
220	0	550	220	0	-550	220	500	0	220	-500	0
220	0	600	220	0	-600	220	550	0	220	-550	0
220	0	650	220	0	-650	220	600	0	220	-600	0
220	0	700	220	0	-700	220	650	0	220	-650	0
220	0	750	220	0	-750	220	700	0	220	-700	0
220	0	800	220	0	-800	220	750	0	220	-750	0
220	0	850	220	0	-850	220	800	0	220	-800	0
220	0	900	220	0	-900	220	850	0	220	-850	0
220	0	950	220	0	-950	220	900	0	220	-900	0
220	0	1000	220	0	-1000	220	950	0	220	-950	0
220	0	1050	220	0	-1050	220	1000	0	220	-1000	0
220	0	1100	220	0	-1100	220	1050	0	220	-1050	0
220	0	1150	220	0	-1150	220	1100	0	220	-1100	0
220	0	1200	220	0	-1200	220	1150	0	220	-1150	0
220	0	1250	220	0	-1250	220	1200	0	220	-1200	0
220	0	1300	220	0	-1300	220	1250	0	220	-1250	0
						220	1300	0	220	-1300	0
						220	1350	0	220	-1350	0
						220	1400	0	220	-1400	0

Table 31: Geometrical Test Points within Side Lobe Zone

C3 Geometrical Test Points Cross-talk protected zone

The following geometrical test points apply (relative distances between the Balise / Reference Loop and the RL_probe):

Z [mm]	Y [mm]	X [mm]	Z [mm]	Y [mm]	X [mm]	Z [mm]	Y [mm]	X [mm]	Z [mm]	Y [mm]	X [mm]
220	0	1350	220	0	-1350	220	1400	0	220	-1400	0
220	0	1400	220	0	-1400	220	1450	0	220	-1450	0
220	0	1450	220	0	-1450	220	1500	0	220	-1500	0
220	0	1500	220	0	-1500	220	1550	0	220	-1550	0
220	0	1550	220	0	-1550	220	1600	0	220	-1600	0
220	0	1600	220	0	-1600	220	1650	0	220	-1650	0
220	0	1650	220	0	-1650	220	1700	0	220	-1700	0
220	0	1700	220	0	-1700	220	1750	0	220	-1750	0
220	0	1750	220	0	-1750	220	1800	0	220	-1800	0
220	0	1800	220	0	-1800	220	1850	0	220	-1850	0
220	0	1850	220	0	-1850	220	1900	0	220	-1900	0
220	0	1900	220	0	-1900	220	1950	0	220	-1950	0
220	0	1950	220	0	-1950	220	2000	0	220	-2000	0
220	0	2000	220	0	-2000	220	2050	0	220	-2050	0
220	0	2100	220	0	-2100	220	2100	0	220	-2100	0
220	0	2200	220	0	-2200	220	2200	0	220	-2200	0
220	0	2300	220	0	-2300	220	2300	0	220	-2300	0
220	0	2400	220	0	-2400	220	2400	0	220	-2400	0
220	0	2500	220	0	-2500	220	2500	0	220	-2500	0
220	0	2600	220	0	-2600	220	2600	0	220	-2600	0
220	0	2700	220	0	-2700	220	2700	0	220	-2700	0
220	0	2800	220	0	-2800	220	2800	0	220	-2800	0
220	0	2900	220	0	-2900	220	2900	0	220	-2900	0
220	0	3000	220	0	-3000	220	3000	0	220	-3000	0

Table 32: Geometrical Test Points within Cross-talk Protected Zone

C4 Test Points for Main Lobe Zone and Side-Lobe Zone

This clause applies for testing of the On-board Transmission Equipment only.

In general, the geometrical test points shall be chosen so that various Antenna Units can be verified with respect to the required contact length and considering potential side lobes at different lateral deviations.

The Antenna Units shall be verified for minimum, nominal, and maximum heights. The nominal height is defined as the sum of the mean value of the static position for the Antenna Unit in question, and the highest specified position of the Balise (93 mm below top of rail). This sub-clause defines the full set of geometrical test points. Tailoring will be made during certain tests (see test matrices according to clauses C6 and C7 of Annex C on pages 210 and 212 respectively).

Please observe that test heights are limited in some specific cases. See sub-clause 5.2.2.2 on page 118.

During testing, the X-positions should be selected according to:

From 0 mm to ± 500 mm, in steps of 20 mm (total of 51 points).

From ± 550 mm to ± 1300 mm, in steps of 50 mm (total of 32 points).

The first zone (from 0 to ± 500 mm) is referred to as main lobe zone in the test matrices of clauses C6 and C7 of Annex C on pages 210 and 212 respectively, and the second zone (from ± 500 mm to ± 1300 mm) is referred to as side lobe zone.

The lateral positions (Y-positions) shall be according to definition of the Antenna Unit supplier (for each lateral deviation, testing shall be performed at the X-positions defined above).

The geometrical test position [$X = 0$, $Y = 0$, $Z = \text{maximum height}$] is denominated the geometrical reference point (see sub-clauses 5.2.3.1 and 5.2.4.1 on page 120 and 124 respectively).

It is the responsibility of the supplier of the Antenna Unit to define the profile of maximum lateral deviation versus vehicle speed. This profile shall take into consideration the requirements on Balise installation (specified in UNISIG SUBSET-036), and the installation dependent requirements for each Antenna Unit type in question (defined by the supplier of the Antenna).

C5 Test Points for Cross-talk protected zone

This clause applies for testing of the On-board Transmission Equipment only.

The following geometrical positions shall be tested:

Point	x [mm]	y [mm]	Point	x [mm]	y [mm]
CT1	0	+1400	CT2	0	-1400
CT3	0	+1600	CT4	0	-1600
CT5	0	+1800	CT6	0	-1800
CT7	0	+2000	CT8	0	-2000
CT9	0	+2200	CT10	0	-2200
CT11	0	+2400	CT12	0	-2400
CT13	0	+2600	CT14	0	-2600
CT15	0	+2800	CT16	0	-2800
CT17	0	+3000	CT18	0	-3000
CT19	0	+3200	CT20	0	-3200
CT21	0	+3400	CT22	0	-3400
CT23	0	+3600	CT24	0	-3600
CT25	+1400	0	CT26	-1400	0
CT27	+1600	0	CT28	-1600	0
CT29	+1800	0	CT30	-1800	0
CT31	+2000	0	CT32	-2000	0
CT33	+2200	0	CT34	-2200	0
CT35	+2400	0	CT36	-2400	0
CT37	+2600	0	CT38	-2600	0
CT39	+2800	0	CT40	-2800	0
CT41	+3000	0	CT42	-3000	0
CT43	+3200	0	CT44	-3200	0
CT45	+3400	0	CT46	-3400	0
CT47	+3600	0	CT48	-3600	0

Table 33: Geometrical test points for On-board Cross-talk verification

The Antenna Unit shall be positioned at the minimum and the maximum heights as defined by the supplier.

C6 Test Matrix for Transmission and Cross-talk tests

C6.1 Test Conditions versus Test Zones

The following applies to tests defined by the sub-clauses 5.2.3 on page 120, 5.2.5 on page 130, and 5.2.9 on page 143. The test zones referred to in the table are defined in the clauses C4 on page 208 and C5 on page 209.

The following combinations of test conditions and test zones shall be tested:

Test Condition	Sub-clause	Main Lobe Zone	Side Lobe Zone	Cross-talk Zone
Nominal	5.2.2.1	X	X	X
Tilt	5.2.2.2.1	X		X
Pitch	5.2.2.2.1	X	X	
Iron Bars	5.2.2.2.3	X	X	X
Guard Rails	5.2.2.2.3	X	X	X
Metallic Plane, Reference Loop	5.2.2.2.3	X	X	
Steel Sleepers	5.2.2.2.3	X		
Other Sleepers	5.2.2.2.3	X		
Loop Cable	5.2.2.2.3	X		X
Metallic Objects; Antenna	5.2.2.2.3	X	X	
Salt Water	5.2.2.2.4	X		
Clear Water	5.2.2.2.4	X		
Iron Ore	5.2.2.2.4	X		
Ice on the Antenna	5.2.2.2.4	X		
Combination	-	X		

Table 34: Transmission and Cross-talk Tests, Test Conditions versus Test Zones

During the first fourteen test conditions, one case is evaluated per test. During the last combined test condition, the following case is applicable:

- Metallic Plane underneath the Reference Loop in combination with Metallic Objects outside the Antenna metal free volume (see sub-clause 5.2.2.2.3 on page 118).

Performance over temperature range is considered through spot check evaluation according to sub-clause 5.2.3.2 on page 122 (and sub-clause 5.2.4 on page 124).

C6.2 Test Conditions versus Geometrical Test Points

The following applies to tests defined by the sub-clauses 5.2.3 on page 120, 5.2.5 on page 130, and 5.2.9 on page 143. The test zones referred to in the table are defined in the clauses C4 on page 208 and C5 on page 209.

During the testing, the number of test points within the contact and side lobe zone shall be according to Table 35 below. The reason is that the number of test points defined in sub-clause C4 on page 208 needs to be minimised.

Test Condition	Sub-clause	Full	R1	R2
Nominal	5.2.2.1	X		
Tilt	5.2.2.2.1		X	
Pitch	5.2.2.2.1		X	
Iron Bars	5.2.2.2.3		X	
Guard Rails	5.2.2.2.3		X	
Metallic Plane, Reference Loop	5.2.2.2.3		X	
Steel Sleepers	5.2.2.2.3		X	
Other Sleepers	5.2.2.2.3		X	
Loop Cables	5.2.2.2.3		X	
Metallic Objects; Antenna	5.2.2.2.3		X	
Salt Water	5.2.2.2.4			X
Clear Water	5.2.2.2.4			X
Iron Ore	5.2.2.2.4			X
Ice on the Antenna	5.2.2.2.4			X
Combinations (see sub-clause C6.1)	-			X

Table 35: Transmission and Cross-talk Tests, Geometrical Test Points within the Main Lobe Zone

The following is applicable:

- ‘Full’ indicates all points according to sub-clause C4 on page 208.
- ‘R1’ indicates maximum and minimum height only. In addition to this, a further limitation is that minimum height only applies within the side lobe zone.
- ‘R2’ indicates maximum height only.

C7 Test Matrix for Other Characteristics

C7.1 Test Conditions versus Characteristics

The following applies to tests defined by the sub clauses 5.2.8 on page 141, 5.2.12 on page 155, 5.2.6 on page 134, 5.2.7 on page 138, 5.2.13 on page 156, and 5.2.14 on page 158. The applicable geometrical test points are further defined by clause C4 on page 208.

The following combinations of characteristics and test conditions shall be tested:

Test Condition	Sub-clause	Up-link Electrical Char. (Sub-clause 5.2.8)	Various Telegrams (Sub-clause 5.2.12)	Tele-powering Char. (Sub-clause 5.2.6)	Maximum Flux Level (Sub-clause 5.2.7)	Balise Sequence (Sub-clause 5.2.13)	Basic Receiver (Sub-clause 5.2.14)
Nominal ²⁹	5.2.2.1	X	X	X	X	X	X
Tilt	5.2.2.2.1						
Pitch	5.2.2.2.1						
Iron Bars	5.2.2.2.3	X	X	X			
Guard Rails	5.2.2.2.3						
Metallic Plane, Reference Loop	5.2.2.2.3	X	X	X	X	X	
Steel Sleepers	5.2.2.2.3	X	X	X			
Other Sleepers	5.2.2.2.3						
Loop Cable	5.2.2.2.3						
Metallic Objects; Antenna	5.2.2.2.3	X	X	X		X	
Salt Water	5.2.2.2.4						
Clear Water	5.2.2.2.4						
Iron Ore	5.2.2.2.4						
Ice on the Antenna	5.2.2.2.4		X				

Table 36: Other Characteristics, Characteristics versus Test Conditions

Tele-powering Characteristics are evaluated at nominal temperature, and at upper and lower temperature extremes.

²⁹ Applicable parts of nominal conditions apply (e.g., during tests of Up-link Electrical Characteristics the conditions for the Up-link signal are modified in accordance with the test procedure, and during testing of various telegrams other telegrams than type 8 are selected). Please refer to the specific test procedures for more details.

C7.2 Test Conditions versus Geometrical Test Points

The following applies to tests defined by the sub clauses 5.2.8 on page 141, 5.2.12 on page 155, 5.2.6 on page 134, 5.2.7 on page 138, 5.2.13 on page 156, and 5.2.14 on page 158. The applicable geometrical test points are further defined by clause C4 on page 208.

During the testing, the number of test points within the Contact and Side Lobe Zone shall be according to Table 37 below. Testing within the cross-talk zone is not applicable for these tests. The reason is that the number of test points defined in clause C4 on page 208 need to be minimised.

Test Case	Sub-clause	R3	R4	R5
Up-link Electrical Characteristics	5.2.8	X		
Various Telegrams	5.2.12	X		
Tele-powering Characteristics	5.2.6		X	
Maximum Flux Level	5.2.7			X
Balise Sequence	5.2.13	X		
Concepts of Basic Receiver	5.2.14	X		

Table 37: Other Characteristics, Geometrical Test Points

The following is applicable:

- 'R3' indicates nominal height with no lateral displacement only.
- 'R4' indicates nominal height at position [X=0, Y=0] only.
- 'R5' indicates minimum height with no lateral displacement and within the Main Lobe Zone only.

C7.3 Source of data for Controlled Balises versus Test Cases

Sub-clause	Test Case	Int. 'C'	Default Telegram	Comment
4.2.2	Up-link Field Conformity	X		All calibrations and tests in free air only. Up-link calibrations for I/O Characteristic measurements are explicitly performed within 4.2.4.
4.2.3	Tele-powering Field Conformity	X		All calibrations and tests for Field Conformity in free air only. However, a few calibrations are made in other conditions and used for I/O Characteristics measurements.
4.2.4	I/O Characteristics, Free Air	X	X	For "Default Telegram", no connection to generator
4.2.4	I/O Characteristics, Other Conditions	X		
4.2.5	Cross-talk Immunity with cables		X	No connection to generator
4.2.6	Balise Impedance		X	No connection to generator
4.2.7	Up-link Signal Characteristics	X	X	For "Default Telegram", connection to (disabled) generator required. A few exceptions explicitly detailed in specific test cases.
4.2.8	Balise controlling interface performance	X		
4.2.9	Test for Damaging		X	No connection to generator

Table 38: Source of data for controlled Balises

Annex D (Informative), Descriptions of Test Tools

D1 Description of Time and Odometer Module (LTOM)

D1.1 Operational Context

The LTOM is required to operate in different test configurations involving the equipment shown in Figure 63. Balises and Reference Loops (used for their simulation) are typically kept in a defined position of the test bed.

In the tests of the On-board transmission equipment, the antenna is kept still over the Reference Loop that is used for simulation of the Balise Up-link signal in the air-gap. In this case, the dynamic Up-link Balise signal, corresponding to the simulated movement of the antenna in the whole speed range from 0 km/h to 500 km/h, is generated by the RSG_1 as realistically as possible at each pre-defined position of the corresponding Balise.

During testing of the overall transmission sub-system, the APT moves the antenna back and forth over the Balise at reduced speed. In order to submit the BTM functionality to realistic conditions, the alternate movement of the antenna can be conveniently “translated” in a mono-directional movement by the LTOM, without losing the control of its real position. The data transmitted by the Balise is consistently updated at each passage.

The LTOM is controlled by the LTMS (or by the operator) in setting up the required operational mode and in providing the relevant input data for the current test step (e.g., speed patterns for each simulated trip, location of Balises to be simulated, etc.). It reports back its current operating status as well as all the test related data that is used as reference for the evaluation of the test results (e.g., time and odometer co-ordinates of the Balise centre).

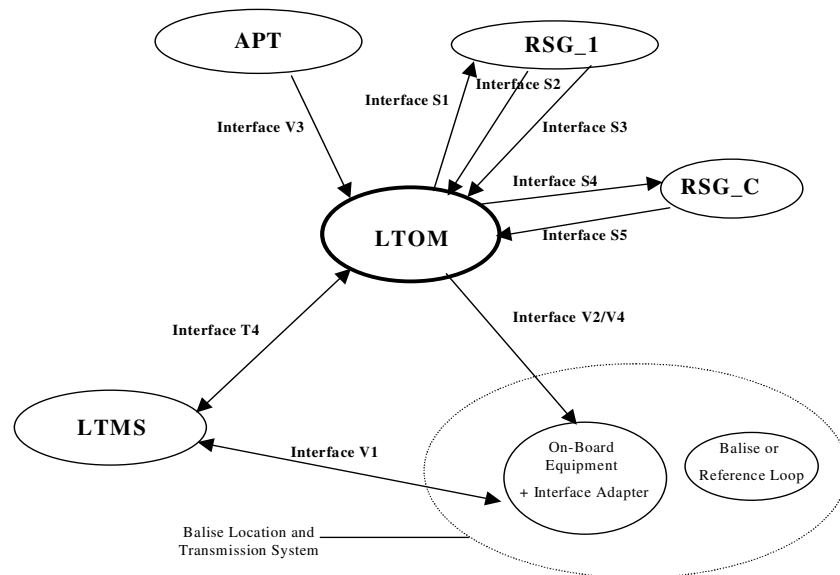

Figure 63: LTOM operational context

D1.2 Functional requirements

D1.2.1 Basic functions

The tool should perform, on external request, one or more basic functions of the following list:

- Accurate generation of the current master time.
- Controllable simulation of antenna movement with pre-defined speed/acceleration patterns.
- Accurate measurement of the current speed and distance of the antenna under test in real low speed conditions.
- Reliable and accurate generation of the time and odometer co-ordinates for driving the BTM functionality under test, in real or in simulated movement condition.
- Reliable and accurate generation of the speed sensor signals expected by the On-board equipment in conditions of low speed real movement of the antenna.
- Accurate distance based trigger for the RSG_1 in order to start the real-time simulation of the dynamic signals of the Up-link Balise.
- Accurate distance based trigger for the RSG_C in order to start the real-time trigger of transient events at the Balise Interface 'C'.
- Recording and stamping with the current time and odometer co-ordinates of the feedback signals coming from the RSG_1 or from the RSG_C at defined instants of the Balise passage simulation.

D1.2.2 Operational modes

D1.2.2.1 General

In order to keep consistency with the information continuously given at the Interface V2 or at the Interface V4, there should be a suitable co-ordination between real and simulated movements at the instants when an operational mode switch occurs.

In addition to the LTMS control ("remote control"), the LTOM should also be controllable, for its basic operations, by the operator ("local control") by means of a suitable Man Machine Interface. The Man Machine Interface should permit the same basic operations that can be commanded by the LTMS and should present in an easily understandable way the same output information required by the LTMS. This manual mode is typically used for simplified verifications of the test set-up or of the equipment under test.

D1.2.2.2 Idle or static mode

It is the default mode at power on or on request of the LTMS or of the operator. In this mode, a standing still condition is simulated. The Interface V2 is driven consistently.

D1.2.2.3 Self-test mode

This mode is aimed at installation and at maintenance support. The basic functionality of the tool is verified with suitable self-test routines. This operational mode may be invoked at the beginning of the test session or whenever it is deemed necessary by the LTMS or by the operator. The test mode can cause interruptions or discontinuities at the LTOM outputs.

D1.2.2.4 Dynamic simulated mode

This mode is required for those tests of the On-board equipment that are scheduled in distance based sequences.

In such cases the antenna is standing still in a defined position with respect to the Reference Loop. The LTOM simulates the movement of the antenna, following pre-defined speed and acceleration patterns. The current time and odometer co-ordinates are evaluated consistently with the current status of the simulated movement. They are periodically broadcast to the Interface V2. The Interface V4 signals are also driven consistently with the simulated movement.

The LTOM is also in charge of triggering the RSG_1 for starting the simulation of the Up-link signals corresponding to a Balise group passage with a pre-defined speed. The simulation of each Balise group starts when a very precise simulated position of the antenna is reached. During the Balise group simulation, the LTOM reads the marker pulse (Balise Centre Marker), generated by the RSG_1 in correspondence of each simulated Balise centre, stamps it with the current time and odometer value and reports it (as soon as possible) to the LTMS. This data is homogeneous and comparable with the test outputs of the BTM functionality (reports at Interface V1 – see clause E1 on page 275).

In order to allow the preparation of the next Balise group simulation, the RSG_1 issues another marker pulse (End of Balise Group Marker) at the end of the current group. This pulse is read by the LTOM, converted into appropriate format and passed on (as soon as possible) to the LTMS for allowing all the required actions for the next simulation step.

D1.2.2.5 Real dynamic mode

This mode is required for those tests that use low speed, real movements of the antenna.

During this operation, the LTOM evaluates the longitudinal speed, the current distance from a reference position and the running direction of the antenna, in order to get the current time and odometer co-ordinates. The inputs for this evaluation are provided by speed sensor signals (Interface V3) of the APT in charge of performing the required movement.

The LTOM keeps constant control of the real position of the antenna during all possible movements and consistently drives both the Interface V2 and the Interface V4.

Despite of this, the LTOM may be requested to “translate” the data sent to the Interface V2, or the signals to the Interface V4, in such a way that the forward/backward movements are understood as “mono-directional” ones by the equipment under test. This allows the simulation of realistic conditions for subsequent Balise passages and longer “virtual” journeys than actually allowed by the size limitations of the test bed.

Some distance-based events can also be triggered by the LTOM, during the movement, in correspondence with pre-defined antenna positions (e.g., telegram switching or insertion of telegram errors, during a Balise/antenna “contact”).

Additionally, suitable marker pulses, generated by the LTOM at defined antenna positions are read back by the same LTOM, stamped with the current time and odometer data and reported to the LTMS as references for the evaluation of some test results.

The LTOM should always be able to keep control of the longitudinal position of the antenna for all the various movement conditions that are possible during a test session.

D1.3 External interfaces

D1.3.1 Interface T4

The Interface T4 is used to exchange commands and data between the LTMS and the LTOM.

The LTMS commands are used to set the LTOM in the required operating mode.

The LTMS data is used either for setting up a defined configuration of the LTOM (e.g., parameters regarding Interface V3 or Interface V4) or for describing specific conditions required for a test sequence (e.g., a distance-based speed/acceleration profile or tables of distance-based triggers for starting the Balise group simulations).

The following list gives examples of possible commands and data from the LTMS to the LTOM:

- Reset speed and position.
- Reset speed, position, time and mode.
- Local control.
- Remote control.
- Simulated dynamic mode.
- Real dynamic mode without direction detection.
- Real dynamic mode with direction detection.
- Test mode.
- Idle mode.
- Status request.
- Request for the current time and odometer co-ordinates.
- Request for the time and odometer stamps corresponding to the recorded marker pulses (Markers Events Table).
- Clear the Marker Events Table.
- Distance parameter corresponding to one period of the Interface V3 signals.
- Distance parameter corresponding to one period of the Interface V4 signals.
- Distance based pattern for speed and acceleration during a train trip simulation.
- Set of distance based triggers for start of Balise group simulation.
- Set of distance based triggers for Interface C event simulation.

A list of possible answers from LTOM to LTMS is:

- Confirmation of successful execution of a received command.
- Information about possible abortion or unsuccessful execution of a received command.
- LTOM current Status (e.g., “not available” or “available” for communication, “not ready” for a new command, “failure condition”).
- Feedback data regarding the controlled test events (e.g., set of time and odometer co-ordinates corresponding to the received input markers).
- Table of the most recent time and odometer co-ordinates broadcast at the Interface V2.
- Confirmation of correct reception of the set of distance-based triggers for Balise group simulation.
- Confirmation of correct reception of the set of distance-based triggers for Interface C events.

D1.3.2 Man Machine Interface

The Man Machine Interface should be realised in such a way as to allow the operator to send, in an easy way, the same commands and data to the LTOM functions as from the LTMS.

The output data from the LTOM should also be graphically displayed in order to allow the operator to check the correct execution of the test steps during both the remote and the local control.

The “local control” via the Man machine Interface should be automatically disabled during the “remote control” operation.

D1.3.3 Interface V2

The Interface V2 is used by the LTOM for periodically broadcasting the current time and odometer co-ordinates towards the BTM functionality under test.

The values given by the LTOM should represent realistic cases for the entire duration of the test session. This requires that the Interface is fed regularly and without interruptions and that the transmitted values are self-consistent during the whole duration of a test session.

The BTM functionality receives the LTOM information through a suitable Interface Adapter provided by each manufacturer. This is in charge of converting the LTOM data (including possible sporadic cases of lack of continuity) to the specific requirements of the equipment under tests.

The following information is periodically broadcast by the LTOM:

- Current time since the start of the test session or since the last “reset”.
- Current distance of the antenna centre from the starting point of the test session or from the last “reset” position.
- Confidence level of the current time and odometer co-ordinates.
- Current value of the longitudinal speed (real or simulated).
- Data for checking the regularity and the integrity of the transmission.

The transmission period should be sufficiently short in relation to the worst-case train acceleration or deceleration.

More details about this Interface are given in clause E2 on page 280.

D1.3.4 Interface V3

The LTOM receives real-time speed/distance signals from the APT containing the following information:

- Distance run by the antenna along the longitudinal direction from a given starting point;
- Instantaneous value of the longitudinal speed;
- Current direction of the movement.

These signals are read and analysed by the LTOM in order to evaluate the current longitudinal position of the antenna, the time and odometer values for the Interface V2 and for the shape of the speed sensor signals produced at the Interface V4.

This interface consists of a pair of square wave signals whose repetition period represents a given distance unit run by the antenna. This parameter is characteristic of the used APT speed sensors. Typically the signal period should correspond to a distance value ranging between 0.1 mm and 1 mm. The phase difference (+90 ° or – 90 °) between the two square waves informs about the APT running direction.

D1.3.5 Interface V4

The LTOM generates a pair of real-time speed signals, coherent with the real longitudinal speed used in the tests, for feeding the On-board equipment under test in a similar way as with the real sensors in the same speed conditions.

The requirements of consistence and continuity, already seen for the data at the Interface V2, apply also in this case.

More details about this Interface are given in clause E3 on page 282.

D1.3.6 Interface S1

During the simulation of a defined train trip, the LTOM issues a suitable distance-based trigger pulse towards the RSG_1 (Balise Group Triggering Pulse) in order to command the generation of the real-time signal corresponding to a defined group of Balises. The various Up-link waveforms, corresponding to each Balise, must be prepared in advance within the RSG_1 (e.g., off-line and/or during the time in which the simulated train “runs” from the previous “Balise group” to the next one). For each Balise group, the triggering pulse corresponds to a pre-defined position of the simulated antenna movement just prior to the location of the Balise group (e.g., at 1 m in advance of the centre of the first Balise of the group).

D1.3.7 Interface S2

During the simulation of the current Balise group, a suitable marker pulse (Balise Centre Marker) is generated by the RSG_1 in correspondence to the location of the centre of each simulated Balise. This pulse is rapidly received by the LTOM, and used for evaluating the time and odometer co-ordinates corresponding to the simulated Balise centre. These co-ordinates include information about time, location and speed of the antenna during the Balise passage. This set of data is sent back, as quickly as possible, to the LTMS for the purpose of evaluation of the test results.

D1.3.8 Interface S3

Immediately after completing the simulation of the current Balise group (e.g., about 1 m after the last Balise centre of the group), the RSG_1 issues a marker pulse (End of Group Marker), to inform the LTMS, via the LTOM, about the conclusion of the current Balise group simulation. This information is used by the LTMS for the analysis of the BTM functionality reported data and for initiating a new test step.

The marker pulse is received by the LTOM, stamped with the current time and odometer co-ordinates and sent back, as quickly as possible, to the LTMS.

D1.3.9 Interface S4

The LTOM issues suitable distance-based trigger pulses towards the RSG_C (Interface ‘C’ Event Trigger) in order to command the generation of defined transient events at the Interface ‘C’ signals, during low speed passages of the antenna over the Balise. The triggering pulse may command the RSG_C to switch from one telegram to another or to insert a pre-defined error pattern in the current telegram, or to simulate a given transient fault.

Trigger pulses of this type may also be generated at periodical distances, during the antenna movement. These pulses fed back into the LTOM, via the Interface S5, allow it to record time and odometer co-ordinates as well as antenna speed at such regular positions. This information is then forwarded to the LTMS as reference data for the verification of the BTM function reports.

D1.3.10 Interface S5

A suitable marker pulse (Interface 'C' Event Marker) is generated by the RSG_C with close time correspondence to the transient event generated at the Interface 'C', in response to the Interface S4 trigger.

Alternatively, the same trigger pulses generated at even distance at the Interface S4 are read back by the LTOM from this interface.

These marker pulses are rapidly received by the LTOM, stamped with the current time and odometer coordinates and sent back as soon as possible to the LTMS for enabling evaluation of the test results.

D1.4 Required performance

The following performance is required of the basic functions of the LTOM:

- For the real antenna movement in the longitudinal direction, the maximum distance of interest is about 5 m. It can be covered in both forward and backward direction. The relevant speed can range from 0 m/s up to 0.5 m/s with a maximum acceleration of the order of $\pm 0.3 \text{ m/s}^2$.
- The maximum distances for the simulated train trips can be up to 43000 km. The relevant speed can range from 0 km/h up to 500 km/h with any acceleration ranging from -2.5 m/s^2 up to $+2.5 \text{ m/s}^2$, in steps of 0.02 m/s^2 .
- The Balise group simulation can be organised, within the RSG_1, in groups of 1 to 8 Balises, spaced in a range of 2.3 m to 5.0 m. Some limitation in the minimum distance (and therefore in the minimum time) between successive group simulations might be imposed by practical limitations of the RSG_1.
- The LTOM shall support static tests where the equipment under test undergoes only time-based conditions (e.g., continuous Balise signal simulation at standing still with telegram switching events).
- The maximum time duration of a continuous test session is longer than 20 hours. During the whole test session, the time and odometer information delivered towards the equipment under test needs to be continuous and consistent with the real/simulated movements of the antenna.
- The time and odometer accuracy/resolution of the information delivered at the LTOM output interfaces (T4, V2, V4, and S1 through S5) for the whole range of test speed should be better than $\pm 5 \text{ mm}$ in distance and $\pm 25 \text{ }\mu\text{s}$ in time.
- In order to avoid possible reactions of the equipment under test, disrupting the correct development of the test procedures, the data provided at the Interface V2 and the signals at Interface V4 should always be consistent and within the specified accuracy for the whole duration of the test session. For special purposes, aimed at simplification of the test procedures, it can be possible to restart ("Reset") the LTOM at its zero position.
- In case of "Reset" the Interface V2 Adapter or the Interface V4 Adapter, should be in charge, if needed, of smoothing possible discontinuities to the requirements of the specific equipment under test.

D2 Description of Reference Signal Generator (RSG)

D2.1 Operational Context

The RSG is used for generating waveforms fulfilling the characteristics that are described in the applicable test procedures and in UNISIG SUBSET-036.

The RSG is intended for use in the simplified environment illustrated by Figure 64 below.

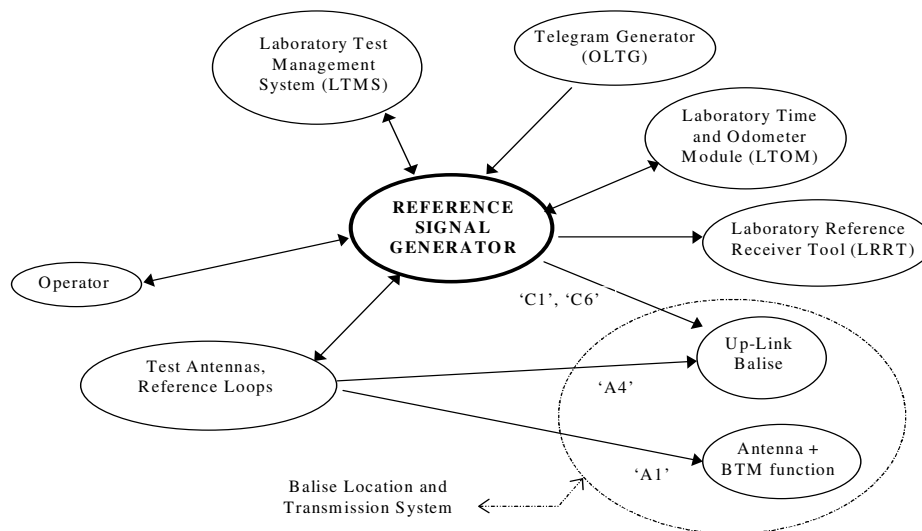

Figure 64: RSG Operational Context

The RSG environment is composed of:

- **Laboratory Test Management System (LTMS).** The LTMS is in charge of managing all the scenarios for the different test procedures.
- **Telegram Generator (OLTG).** The data (Eurobalise telegrams) used for the generation of telegrams transmitted via the Interface 'A1' and Interface 'C1' are generated with the specific Telegram Generator.
- **Time and Odometer Module (LTOM).** The LTOM is in charge of delivering the current time and position to the BTM function. It is also in charge of the stamping (in time and position) the theoretical Balise centre for simulated Balise passages. The Balise centre information is provided by the RSG (a position/time marker pulse).
- **Test Antennas and Reference Loops.** The Test Antennas (a set of various antennas including test antennas and activation antennas) and Reference Loops (standard size and reduced size) are used to transmit the air-gap signals.
- **Reference Receiver (LRRT).** The LRRT is in charge of the reception of Up-link telegrams at Interface 'A1'.

The RSG is used to test the following Eurobalise devices:

- **Antenna and BTM functionality.** During static conditions, the RSG generates the (Up-link) signal for Interface 'A1'. In order to simulate a dynamic sequence, the RSG generates a signal simulating the signal transmitted by a Balise being passed by a train, including the radiation pattern of the specific On-board antenna. In this sequence, the RSG supplies the following signals :
 - FSK Up-link signal.
 - Balise Passage signal (PB2), and the radiation pattern.
 - End of transmission marker for a group of Balises.
 - Marker for the passage of the train over the centre of a Balise, and a telegram-switching marker.
- **Up-link Balise.** In order to test the performance of the Up-link Balise, the RSG generates the Interface 'C' signals and the Tele-powering signal (Interface 'A4'). The amplitude of the Tele-powering signal is modulated by a signal simulating the train passing over the Balise. A marker indicates the expected start of transmission of a telegram.
 - Tele-powering signal.
 - Balise Passage signal (PB1) and a marker that indicates that the signal has reached the flux level ϕ_{a1} (as a result of the measurement of the Test Antenna current).
 - Interface 'C' signals.
 - Interface 'C' signals with various generated Return Loss conditions.
 - Start of transmission marker on Interface 'C'.

D2.2 Functional requirements

D2.2.1 Basic functions

D2.2.1.1 General

The RSG is functionally divided into the following three parts:

- RSG_1. Generates the Up-link FSK test waveforms (including dynamic patterns).
- RSG_2. Generates the Tele-powering test waveforms (including dynamic patterns).
- RSG_C. RSG_C. Generates the Interface 'C' test waveforms (including alteration of the source impedance during Return Loss testing).

D2.2.1.2 RSG_1

The following Table 39 lists various test cases requiring the RSG_1 functionality. For each case, the required operational mode is indicated.

Item	Test Case	Operational mode
1	Calibration of 4.2 MHz Balise loop current	Continuous mode
2	Calibration of Balise input to output characteristics	Continuous mode
3	Cross-talk immunity tests (Up-link)	Continuous mode
4	Cross-talk immunity with cables	Continuous mode
5	Evaluation of radiation pattern	Continuous mode Single mode
6	Transmission tests	Continuous mode Single mode
7	Electrical Up-link characteristics	Continuous mode Single mode
8	Cross-talk immunity tests	Continuous mode Single mode
9	Cross-talk immunity with cables	Continuous mode Single mode
10	Test of handling of various telegrams	Continuous mode Single mode Switching mode
11	Balise Sequence capability tests	Sequence mode

Table 39: Test cases versus functionality

D2.2.1.3 RSG_2

The following Table 40 lists various test cases requiring the support of the RSG_2 functionality. For each case the required operational mode is indicated.

Item	Test Case	Operational mode
1	Calibration of 27 MHz Tele-powering flux	Continuous mode CW
2	Balise Up-link conformity measurements	Continuous mode CW
3	Balise Tele-powering conformity measurements	Continuous mode CW
4	Balise Input to Output characteristics	Continuous mode CW
5	Cross-talk immunity with cables	Continuous mode CW
6	Measurements of Balise Up-link electrical characteristics	Continuous mode CW Single mode CW Single mode Toggling Single mode Non-toggling
7	Delay time and Interface 'C' parameter variation	Continuous mode CW
8	Interface 'C' performance measurements	Continuous mode CW Single mode CW
9	KER compatibility	Single mode CW
10	Calibration of Balise response	Continuous mode CW

Table 40: Test cases versus functionality

D2.2.1.4 RSG_C

The following Table 41 lists various test cases requiring the RSG_C functionality. For each case the required operational mode is indicated.

Item	Test Case	Operational mode
1	Up-link signal characteristics	Continuous mode
2	Delay time and Interface 'C' parameter variation.	Continuous mode
3	Interface 'C' performance measurements	Continuous mode Modified telegram mode
4	Default telegram switching	Switching mode
5	Blocking of telegram switching	Continuous mode
6	KER compatibility	Continuous mode
7	Return Loss testing	Continuous mode

Table 41: Test cases versus functionality

D2.2.2 Operational modes

D2.2.2.1 RSG_1

D2.2.2.1.1 General

RSG_1 functionality intends to provide, under local or remote control, generation of signals in one of the following modes.

D2.2.2.1.2 Continuous mode

This includes continuous generation of an FSK signal simulating the transmission of one telegram. The functionality does not need a trigger to start the generation.

D2.2.2.1.3 Single mode

This includes generation of an FSK signal (simulating the transmission of one telegram) modulated with the radiation pattern, or with the signal that simulates a Balise passage (PB2). The generation is triggered (either a software trigger by the LTMS, or a hardware trigger by the LTOM). The RSG provides the Balise centre marker to the LTOM.

D2.2.2.1.4 Switching mode

This includes generation of an FSK signal (simulating the transmission of one telegram) modulated with the radiation pattern, or with a signal that simulates a Balise passage (PB2). It simulates a telegram switch. For the telegram-switching test, the functionality provides a second marker, the telegram-switching marker, which indicates the beginning of the second telegram.

D2.2.2.1.5 Sequence mode

This includes generation of a sequence of Balise passages with a specific telegram for each Balise passage. The generation is triggered by the LTOM. The RSG provides the Balise centre marker for each Balise passage and an end of group marker.

D2.2.2.2 RSG_2

D2.2.2.2.1 General

The RSG_2 functionality intends to provide, under local or remote control, generation of signals in one of the following modes.

D2.2.2.2.2 Continuous mode CW

This includes continuous generation of a Continuous Wave (CW) Tele-powering signal at a frequency of 27.095 MHz.

D2.2.2.2.3 Single mode CW

This includes generation of a 27.095 MHz Tele-powering signal, but the flux is modulated to simulate a train passage (PB1). The generation is triggered (either by a software trigger from the LTMS, or by a hardware trigger from the LTOM). The RSG provides a marker which indicates that the signal has reached the flux level ϕ_{d1} .

D2.2.2.2.4 Single mode non-toggling

This includes generation of a 27.095 MHz Tele-powering signal that is modulated with a Non-toggling AM signal. The flux is also modulated to simulate a train passage (PB1). The generation is triggered (either by a software trigger from the LTMS, or by a hardware trigger from the LTOM). The RSG provides a marker which indicates that the signal has reached the flux level ϕ_{d1} .

D2.2.2.2.5 Single mode toggling

This includes generation of a 27.095 MHz Tele-powering signal that is modulated with a Toggling AM signal. The flux is also modulated to simulate a train passage (PB1). The generation is triggered (either by a software trigger from the LTMS, or by a hardware trigger from the LTOM). The RSG provides a marker which indicates that the signal has reached the flux level ϕ_d .

D2.2.2.3 RSG_C

D2.2.2.3.1 General

The RSG_C functionality intends to provide, under local or remote control, generation of signals in one of the following modes.

D2.2.2.3.2 Continuous mode

This includes the continuous generation of a signal simulating the transmission of one telegram. The RSG provides a marker that indicates the beginning of the telegram.

D2.2.2.3.3 Switching mode

This includes the continuous generation of a signal simulating the transmission of one telegram. A simulated telegram switch changes to another telegram after reception of a pulse command from the LTOM. The RSG provides a marker that indicates the beginning of new the telegram.

D2.2.2.3.4 Modified telegram mode

This includes the continuous generation of a signal simulating the transmission of one telegram. A simulated event in a telegram (errors or other simulated failures) occurs after reception of a pulse command from the LTOM. The RSG provides a marker that indicates the resumption of the telegram after the simulated event.

D2.3 External interfaces

D2.3.1 RSG_1

D2.3.1.1 Interface with the LTMS

The LTMS needs specific commands in order to control the RSG for simulating the required signal. The required signal is defined in the test scenario loaded in the LTMS and adjusted via the measurements of the signal generated by the RSG. Therefore, power meters connected to the reference loop perform measurements.

D2.3.1.2 Interface with the LTOM

D2.3.1.2.1 Triggering pulse

During the simulation of a defined case, the LTOM issues a suitable trigger pulse towards the RSG in order to command the generation of signals.

D2.3.1.2.2 Balise centre marker

Correlated with the centre of each Balise, a marker is generated by the RSG. The pulse is received by the LTOM and used to evaluate the time and odometer co-ordinates of the simulated Balise centre.

D2.3.1.2.3 End of group marker

In order to allow down-loading of new waveforms, immediately after completing the simulation of the current Balise group, the RSG issues a suitable marker signal. It is received by the LTOM.

D2.3.1.2.4 Telegram switching marker

Correlated with any telegram switching, or other similar events during the simulated Up-link Balise signal, a suitable marker pulse is generated by the RSG.

D2.3.2 RSG_2

D2.3.2.1 Interface with the LTMS

The LTMS needs specific commands in order to control the RSG for simulating the required signal. The required signal is defined in the test scenario loaded in the LTMS and adjusted via the measurements of the signal generated by the RSG. Therefore, power meters connected to the test antennas do measurements.

D2.3.2.2 Test Antenna

The Test Antenna requires the source impedance of the generator of 50 Ω . The generator tolerates fluctuating impedance caused by the variation of the test object impedance.

D2.3.2.3 Current Sense (CS) from Test Antenna

The needed input power and modulation depth is dependent on the dynamic impedance of the test object. The correct flux level is related to the measurement performed at the current sense output, considering a specific calibration procedure.

D2.3.2.4 Interface with the LRRT

The marker of the level ϕ_{d1} , provided by the RSG, indicates that the RSG reaches the flux level ϕ_{d1} (the interface denomination is Interface S6).

D2.3.3 RSG_C

D2.3.3.1 Interface with the LTMS

The LTMS needs specific commands in order to control the RSG for simulating required signals.

D2.3.3.2 Interface with the LTOM

D2.3.3.2.1 Start of transmission marker

It indicates the start of the transmission of a new message. It is also used for some tests to start the LRRT measurements.

D2.3.3.2.2 Switching trigger

This trigger, provided by the LTOM, allows the switch from a first telegram to a second telegram (or simulated error). The telegram switching must be effected, after reception of trigger, immediately after the preceding telegram has been completed.

D2.4 Required performance

D2.4.1 RSG_1

From the list of the required functionality summarised in sub-clause D2.2.1.2, the following minimum performance can be extracted when considering the requirements of UNISIG SUBSET-036:

- **Output Level Requirements.** The RSG should be able to increase or decrease its output power in steps of 0.2 dB. The RSG should be able to reach the peak current level $I_{u3} + 20$ dB in the applicable Reference Loop. The accuracy should be better than 0.05 dB, and the resolution should be better than 0.1 dB.
- **Up-link Requirements.** The RSG should be able to generate the Up-link signal with the following characteristics.

Characteristics	Nominal value	Min/max values	Accuracy	Resolution
Centre Frequency	4.233 MHz	4.033 MHz / 4.433 MHz	20 kHz	1 kHz
Frequency Deviation	282.24 kHz	268.13 kHz / 296.36 kHz	3.0 kHz	10 Hz
Mean data Rate	564.48 kbit/s	550.36 kbit/s / 578.59 kbit/s	0.01 %	0.01 kbit/s
Amplitude Jitter	0 dB	+1.5/-2.0 dB	0.15 dB	0.15 dB
MTIE	See sub-clause 5.2.2.1.4	See UNISIG SUBSET-036		

Table 42: Up-link characteristics

- **Radiation Pattern or Balise Passage Requirements.** The RSG should be able to generate these signals with an accuracy of better than 0.01 ms.
- **Operational mode.** The RSG should be able to operate in four different modes (see sub-clause D2.2.2.1).

D2.4.2 RSG_2

From the list of required functionality summarised in sub-clause D2.2.1.3, the following minimum performance can be extracted when considering the requirements of UNISIG SUBSET-036:

- **Output Level Requirements.** The RSG should be able to increase or decrease its output power in steps of 0.2 dB. The RSG shall be able to generate a flux level from $\phi_{d1} - 5$ dB to ϕ_{d5} .
- **Tele-powering Requirements.** The RSG should be able to generate the Tele-powering signal with the following characteristics:

Characteristics	Nominal value	Min/max values	Accuracy	Resolution
CW frequency	27.095 MHz	27.090 MHz / 27.100 MHz	0.5 kHz	0.1 kHz
Carrier Noise		< 110 dBc/Hz		

Table 43: CW characteristics

Characteristics	Nominal value	Min/max values	Accuracy	Resolution
AM frequency	50.0 kHz	49.990 kHz / 50.010 kHz	1 Hz	1 Hz
Modulation depth	100 %	50 % / 100 %	5 %	1 %
Pulse width		2.0 μ s / 3.5 μ s	0.15 μ s	0.1 μ s
Pulse width jitter		< \pm 0.1 μ s		
Amplitude variation		< 0.5 %		

Table 44: Non-toggling modulation characteristics

Characteristics	Nominal value	Min/max values	Accuracy	Resolution
AM frequency	50.0 kHz	49.990 kHz / 50.010 kHz	1 Hz	1 Hz
Modulation depth	100 %	50 % / 100 %	2 %	1 %
Pulse width		2.0 μ s / 3.5 μ s	0.15 μ s	0.1 μ s
Pulse width variation		0.8 μ s / 1.5 μ s	0.1 μ s	0.1 μ s
Amplitude variation		< 0.5 %		

Table 45: Toggling modulation characteristics

- **Balise Passage Requirements.** The RSG should be able to generate this signal with an accuracy of better than 0.01 ms.
- **Operational mode:** The RSG should be able to operate in four different modes (see sub-clause D2.2.2.2).

D2.4.3 RSG_C

From the list of required functionality summarised in sub-clause D2.2.1.4, the following minimum performance can be extracted when considering the requirements of UNISIG SUBSET-036:

The Interface C1 signal is a Differential Bi-phase level coded signal simulating the transmission of one telegram.

Characteristics	Nominal value	Min/max values	Accuracy	Resolution
Signal level (V ₂)	16.0 Vpp	14 Vpp / 18.0 Vpp	0.1 Vpp	0.1 Vpp
Mean data rate	564.48 kbit/s	564.36 kbit/s / 564.60 kbit/s	20 ppm	0.01 kbit/s
Time jitter	0 ns	< ± 60 ns	10 ns	
Normal Return Loss		≥ 23 dB		
Extreme Return Loss	6 dB	5.5 dB / 6 dB		

Table 46: Interface 'C1' characteristic

The RSG should also be able to simulate the extremes of the Eye Diagram parameters and respect minimum rise time and fall time requirements (see UNISIG SUBSET-036).

The RSG shall be able to simulate various Return Loss conditions used for testing the source impedance effect of the Interface 'C1'.

Characteristics	Nominal value	Min/max values	Accuracy	Resolution
Signal level	22.0 Vpp	20.0 Vpp / 23.0 Vpp	0.15 Vpp	0.1 Vpp
Frequency	8.820 kHz	8.72 kHz / 8.92 kHz	10 Hz	1 Hz
Second Harmonic		< -20 dBc		
Harmonic content		< -40 dBc (0.1 MHz to 1 MHz)		
Normal Return Loss		≥ 23 dB		
Extreme Return Loss	4 dB	3.8 dB / 4 dB		

Table 47: Interface 'C6' characteristics

The RSG shall be able to simulate various Return Loss conditions used for testing the source impedance effect of the Interface 'C6'.

D3 Description of Antenna Positioning Tool (APT)

D3.1 Operational Context

The APT is required to operate in different test configurations involving the equipment shown in Figure 65.

The APT is used to locate either the On-board Antenna or the Test Antenna tools in various, X, Y, and Z positions and with different angular displacements relative to the Balise under test, or to the Reference Loop tools. Balises or Reference Loops are typically kept in a defined fixed position that constitutes the origin of the spatial reference system used for defining the movements.

The APT is automatically controlled in its basic X, Y, and Z movements either in response to the operator's commands via Man Machine Interface in "local control", or in response to LTMS commands in "remote control". Angular displacements, less frequently changed, can be controlled either in a similar automatic way or manually.

The antenna positioning may be performed in a quasi-static way (e.g., move for a defined step towards the target position, stop and evaluate the current position error, move again one step, and so on up to minimise the position error) or continuously.

The APT shall also allow for static tests where the antenna is held still for indefinite time in a given position, during manual tests or during adjustments of the test set-up.

Finally, the APT shall also allow for continuous movements in the longitudinal direction, at nearly constant speed or with pre-defined speed patterns, in order to simulate the train movement at low speed. For this case, the tool should provide the LTOM with real-time speed/distance signals or data allowing continuous and accurate monitoring of longitudinal speed and position of the carried antenna.

The minimum volume of interest for the movement is about 3.6 m in the longitudinal direction by 1.5 m in the lateral direction by 0.4 m in the vertical direction. The required positioning accuracy is higher in the central volume ("main lobe zone"), and less demanding outside. A rotation of the table along the three axes (vertical, longitudinal, and lateral ones) shall also be possible from 0° to ±15° with sufficient accuracy and resolution.

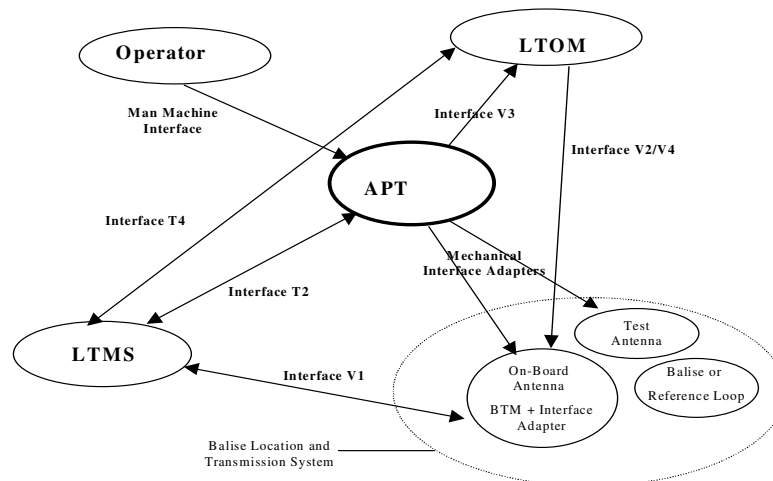

Figure 65: APT operational context

D3.2 Functional requirements

D3.2.1 Basic functions

The APT is basically composed of the following sub-assemblies:

- Fixed, highly stable, mechanical frame holding the whole system.
- Accurately moving (along X, Y, and Z axes) and rotating head (around X, Y, and Z axes).
- Set of mechanical Interface Adapters for fixing various types of On-board antennas and of Test Antennas to the moving head.
- Movement actuators and relevant transducers.
- Electronic drives for the actuators.
- Controller/supervisor of the drives.
- Interface to the LTMS.
- Interface to the LTOM.
- Diagnostic tools for verification of the positioning accuracy and for alignment of the moving head with the fixed test bed holding the Balise or the Reference Loop.

The tool should perform, on external request, one or more basic functions of the following list:

- Interfacing with the operator.
- Interfacing with the LTMS.
- Interfacing with the LTOM.
- Self-checking of all the basic functions of the tool.
- Searching for the Positioning Reference Point.
- Recovery of the lost Positioning Reference Point.
- Detection and reporting of the current position.
- Positioning the moving head along the X-axis.
- Positioning the moving head along the Y-axis.
- Positioning the moving head along the Z-axis.
- Rotating the moving head around the X-axis (Tilting).
- Rotating the moving head around the Y-axis (Pitching).
- Rotating the moving head around the Z-axis (Yawing).
- Positioning the moving head to a given point (X, Y, Z) with any combination of angular displacement.
- Continuously moving the moving head along the X-axis, at given longitudinal, vertical and angular displacements.

D3.2.2 Operational modes

D3.2.2.1 General

The two basic operational modes are “remote control”, via Interface T2 under full supervision of the LTMS, and “local control”, via a suitable Man Machine Interface under control of the operator.

The Man Machine Interface should permit the same basic operations that can be commanded by the LTMS and should present in an easily understandable way the same output information. This manual mode is typically used for simplified verifications of the test set-up or for aligning the Balise or Reference Loop to the required test position.

Independently of the internal reference system used by the APT controlling logic, all data regarding positioning of the Balise, and of the antenna, shall be translated in such a way that the operator and the LTMS can always refer to the reference axes, origins of co-ordinates, and angular displacements defined in Clause 4.5.1 of UNISIG SUBSET-036.

D3.2.2.2 Idle mode

This is the default mode at power on or on request from the LTMS or the operator. In this mode, a safe standing still condition is achieved. This mode is typically used when test staff is working in the area of the test bed. It is recommended, for this operational mode, that high safety level is ensured against unwanted movements of the moving head.

D3.2.2.3 Self test mode

This mode is aimed at installation and at maintenance support. The basic functionality of the tool is verified with suitable self-test routines. This operational mode may be invoked at the beginning of the test session or whenever it is deemed necessary by the LTMS or by the operator. The test may consist, for example, in automatically positioning the antenna at pre-stored checkpoints and in verifying, with the help of absolute position sensors or precision tools, the correctness of the reached positions.

D3.2.2.4 Recovery of the lost position

If the APT loses, for any reason, the control of the current antenna position, it can start a recovery procedure after informing the operator (through the MMI) and/or the LTMS with a suitable error code. This procedure includes the return to the nearest “home position” equipped with absolute position sensors, the detection of such position and the re-initialisation of the software. The help of the operator can be invoked and guided if some action must be performed manually.

D3.2.2.5 Quasi static antenna positioning

This mode is required for all Balise tests and for most tests of the On-board equipment.

The antenna positioning is done with discrete steps along the X, Y, and Z axes, possibly following a time-optimised path. Typically, only the initial and the final positions are of interest in this type of operation. The intermediate ones have no specific interest for the measurements and for the required accuracy.

However, in some cases, when objects exposed to the moving antenna might be present the test bed, it could be necessary to put some constraints to the free movement towards a given final position. A case when this is absolutely needed is, for example, in those tests that require the debris box in the test bed.

Some tests require measurements with the antenna in very numerous different positions. In such cases, the positioning time takes an important part of the overall test time, therefore it is recommended to use positioning algorithms that combine the movements along the various axes in such a way as to minimise the travelling time.

Depending on the construction of the moving head and on the type of mechanical Interface Adapters used for fixing the Antenna, it may be necessary that the positioning algorithms provide means to compensate for the X, Y, and Z position errors introduced by angular displacement (Tilting and Pitching) around axes not coincident with the antenna Reference Axes.

D3.2.2.6 Continuous longitudinal antenna movement

This mode is required for those tests that use low speed, real movements of the antenna.

Keeping constant the lateral, vertical, and angular displacements, it shall be possible to run a continuous longitudinal movement at nearly constant speed in order to simulate a Balise passage at low speed. It should be possible to achieve constant speed of 0.2 m/s^2 to 0.5 m/s^2 for the whole main lobe zone centred over the Balise under tests (e.g., for X included between -0.5 m and 0.5 m).

A typical continuous movement is characterised by a constant acceleration phase lasting for about 0.3 m to 0.5 m , a constant speed phase lasting for about 1 m to 2 m , and by a constant deceleration phase lasting for about 0.3 m to 0.5 m .

Also in this case, it may be necessary that the movement control algorithms provide means to compensate for the X, Y, and Z position errors introduced by angular displacement (Tilting and Pitching) around axes not coincident with the antenna Reference Axes.

D3.3 External interfaces

D3.3.1 Interface T2

The Interface T2 is used to exchange commands and data between the LTMS and the APT.

The LTMS commands are used to set the APT in the required operating mode and to get the desired antenna position or movement.

The following list gives examples of possible commands and data from the LTMS to the APT:

- Switch to local control.
- Switch to remote control.
- Emergency Stop.
- Send APT configuration data.
- Go to the idle status.
- Return to “home”.
- Perform self-test.
- Report current position.
- Go to the next position X, Y, and Z with the given angular displacements and movement constraints.
- Move from the current position along the X-axis (or Y-axis or Z-axis) by a given step value with the given angular displacements and movement constraints.
- Perform a continuous longitudinal movement within the defined X co-ordinate range, with the given lateral, vertical, and angular displacements and at a required top speed.

A list of possible answers from APT to LTMS is:

- Confirmation of successful execution of a received commands.
- Information about possible abortion or unsuccessful execution of a received command.
- APT current Status (e.g., “not ready” for a new command, “failure condition”).
- Report about the current position and angular displacements.

D3.3.2 Man Machine Interface

The Man Machine Interface should be realised in such a way as to allow the operator to send, in an easy way, the same commands and data to the APT functions as from the LTMS.

The output data from the APT should also be graphically displayed in order to allow the operator to easily check the correct execution of the test steps during both the remote and the local control. Acoustical warnings should be issued when the operator is required to perform critical actions.

The “local control” via the Man machine Interface should be automatically disabled during the “remote control” operation.

Nonetheless, an Emergency Stop command should be easily available to the operator to quickly overrun any other command or internal operational condition in case of dangerous situations.

D3.3.3 Interface V3

The APT sends real-time information to the LTOM about the current distance run by the antenna along the longitudinal direction from a given starting point, the instantaneous value of the longitudinal speed and the current direction of the movement.

This information is processed by the LTOM in order to monitor the current longitudinal position and speed of the antenna and to control accordingly the required test procedures.

More details on this interface are given in sub-clause D1.3.4 on page 219.

D3.4 Required performance

D3.4.1 Test bed characteristics

The following performance is required of the basic functions of the APT:

- The minimum volume of interest for the positioning is about 3.6 m in the longitudinal direction, by 1.5 m in the lateral direction, by 0.5 m in the vertical direction. The required positioning accuracy is higher in the central volume (“main lobe zone”), and less demanding outside. A rotation of the table along the three axes (X, Y, and Z) shall also be possible. In particular the Pitching angle should range from 0 ° to ±5 °, the Tilting angle from 0 ° to ±10 °, and the Yawing angle from 0 ° to ±5 °. These angular displacements may occur in any possible combination.
- A continuous longitudinal movement of the antenna in both forward and backward direction should be possible in a range of 2 m to 4 m, at a nearly constant speed of 0.1 m/s to 0.5 m/s, with a maximum acceleration of the order of ±0.3 m/s².
- The available power for movement control should be sufficient for ensuring the required acceleration/deceleration values.
- The quasi-static positioning in X and Y directions may be limited to only positive co-ordinates. Tests requiring negative co-ordinates can be done by properly rotating the Balise and the antenna. For such needs, the Yaw angle can also be set to ±180 °. In a similar way, by rotating the Balise and antenna by a Yaw angle of ±90 °, it is possible to transform a transversal movement into a longitudinal one. This allows some economy both in the APT and in the requirements on the size of the test room.
- In order not to get disturbances of the tests from the surrounding environment, there shall be a space free from metallic objects around the Balise, and in the whole space occupied by the antenna in the various test positions, as indicated in sub-clause 4.1.1 of this specification.
- The vertical and angular positioning of the antenna may be done with some manual intervention coordinated and assisted by the APT logic.
- The mechanical frame holding the moving parts shall have enough inertia and stability to easily absorb possible counter-effects of the movement and to minimise vibrations of the carried antenna.
- The maximum payload of the APT should be of about 30 kg, including the weight of the antenna, the possible mechanical frames for its mounting, the debris (see sub-clause 5.2.3) or the metallic objects (see sub-clause 5.3.7) used in the tests. The maximum size of the antenna is about 640 mm × 640 mm × (h = 200) mm. The size and the shape of the Test Antenna are given in sub-clause J3.3.
- Enough free space should be required around the nominal Balise area, in order to allow for the installation of the debris box (see sub-clause D5.2), or the reference units simulating the effect of guard rails, metallic sleepers, metallic plates, cables or metallic masses in the tracks, as defined in sub-clause D5.3.

- Suitable protections (preferably APT independent) shall be used for avoiding dangerous situations for both personnel and equipment in case of failure or malfunction of the APT controlling devices.

D3.4.2 Positioning Accuracy

Three main areas are identified for the antenna positioning/movement in a plane parallel to the XY plane, at a given height Z:

- The “main lobe zone”, a square delimited by the lines $X = \pm 500$ mm and $Y = \pm 400$ mm;
- The “side-lobes zone” a square delimited by the lines $X = \pm 1400$ mm and $Y = \pm 1400$ mm, with the exclusion of the main lobe zone;
- The “cross-talk protected zone”, a square delimited by the lines $X = \pm 3600$ mm and $Y = \pm 3600$ mm, with the exclusion of the contact and the side lobe zones.

The X, Y, and Z co-ordinates are referred to the Balise Reference System defined in sub-clause 4.5.1 of UNISIG SUBSET-036.

The positioning accuracy and resolution depend on the considered zone. Finer resolution and better accuracy are required for the inner zones. The whole ranges for the antenna positioning parameters with the respective resolution/accuracy requirements are summarised in the following Table 48. Similar indications for the Balise positioning are summarised in Table 49 as well.

It should be observed that, in the event of achieving better accuracy in Balise positioning than the maximum tolerances stated by Table 49, this will increase the allowed maximum tolerances of Table 48 accordingly. This is applicable to positions in the main lobe zone and to angular displacements.

Parameter	Range of variation	Minimum Resolution	Maximum Tolerance
Z	0 mm to +400 mm	10 mm	±1 mm
X - main lobe zone	-500 mm to +500 mm	5 mm	±1 mm
X - side-lobe zone	-1400 mm to +1400 mm	10 mm	±2 mm
X - cross-talk prot. zone	-3600 mm to +3600 mm	50 mm	±10 mm
Y - main lobe zone	-400 mm to +400 mm	5 mm	±1 mm
Y - side-lobe zone	-1400 mm to +1400 mm	10 mm	±2 mm
Y - cross-talk prot. zone	-3000 mm to +3000 mm	50 mm	±10 mm
Ti tilting	-10 ° to +10° (0 ° to 20 ° with adapter)	1 °	±0.25 °
Pi pitching	-5 ° to +5° (0 ° to 10 ° with adapter)	1 °	±0.25 °
Yo yawing	-5 ° to +5 ° (0 ° to 10 ° with adapter)	1 °	±0.25 °
	-90 ° to +90 ° (manually)	90 °	±0.25 °
	-180 ° to +180 ° (manually)	90 °	±0.25 °

Table 48: Antenna positioning ranges, resolution, and accuracy

Parameter	Range of variation	Minimum Resolution	Maximum Tolerance
Z	-210 mm to -93 mm	10 mm	±1 mm
X	-3000 mm to +3000 mm	500 mm	±1 mm
Y	-1400 mm to +1400 mm	200 mm	±1 mm
Ti tilting	-2 ° to +2 °	1 °	±0.25 °
Pi pitching	-5 ° to +5 °	1 °	±0.25 °
Yo yawing	-10 ° to +10 °	1 °	±0.25 °
	-90 ° to +90 °	90 °	±0.25 °
	-180 ° to +180 °	90 °	±0.25 °

Table 49: Balise positioning ranges, resolution, and accuracy

D4 Description of Off-line Telegram Generator (OLTG)

D4.1 Operational Context

The OLTG is the tool used for generation of test telegrams, and for checking received telegrams, in accordance with the coding requirements of UNISIG SUBSET-036. This includes:

- Generation of test telegrams to be used at Interface 'C' and Interface 'A'.
- Checking of telegrams received at Interface 'A' and Interface 'V'.
- Generation of telegrams for the internal Up-link Balise memory (the Default Telegram).

The OLTG is intended for use in the simplified environment illustrated by Figure 66 below.

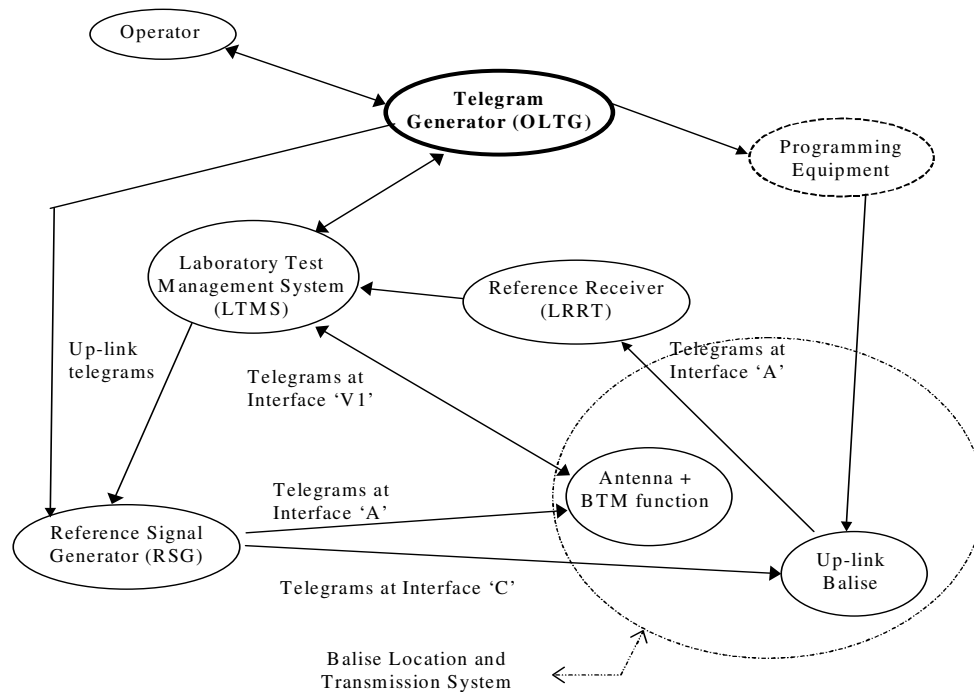

Figure 66: OLTG Operational Context

The OLTG environment includes the following:

- **Antenna and BTM functionality.** The tests of the Antenna and BTM functionality need the OLTG for generation of test telegrams intended for transmission via the Interface 'A1' (Up-link functionality). It can also be used for checking the actually received telegrams via Interface 'V'.
- **Up-link Balise.** The tests of the Up-link Balise performance need the OLTG for generation of telegrams intended for transmission via Interface 'C1'. The same applies for telegrams stored in the internal Balise memory (the Default Telegram). The OLTG can also be used for checking the actually transmitted telegrams via Interface 'A1'.
- **Operator.** Human operator to operate the OLTG.

- **Test Management System (LTMS).** The LTMS is in charge of the management of all the test procedures and test tools.
- **Reference Signal Generator (RSG).** The RSG is in charge of the transmission of Up-link telegrams at Interface 'A1' and Interface 'C1'.
- **Reference Receiver (LRRT).** The LRRT is in charge of the reception of Up-link telegrams at Interface 'A1'.
- **Programming Equipment.** The (company specific) programming equipment is in charge of the programming the internal Balise memory with the intended Default Telegram.

D4.2 Functional requirements

D4.2.1 Basic functions

The following functions should be implemented in the OLTG:

- **Encoding function.** This function is used to transform the user data into a Eurobalise telegram.
- **Decoding function.** Considering that the OTGL should be used as reference tool for the coding strategy verification, this function is integrated in order to check the integrity of telegrams against the coding requirements possibly generated by other sources. This function is also used to verify that a string of bits (341 bits or 1023 bits) fulfils the coding requirements.
- **MMI functions.** These functions are used as interface between the OLTG and other tools or the operator.

The Man Machine Interface should be graphically based, and provide the following functionality.

For the encoding function:

- Entering user data to be encoded.
- Storing user data in a file.
- Encoding more than one telegram.
- Storing encoded telegrams in a file.

For the decoding function:

- Loading files containing the encoded telegram.
- On the screen displaying the CRC checking of the telegrams and the user data after decoding.
- Storing user data in a file.

D4.2.2 Functional architecture

The Telegram Generator could be composed of five main parts (see Figure 67).

- **Graphical User Interface (GUI).** Manages the calls of the different software functions.
- **User Data Interface.** For entering and storing the user data and displaying the result of decoding. The user data can be typed by the operator or loaded from a file.
- **Encoding/Decoding.** Encodes the user data and decodes the encoded telegram.
- **Encoded Telegram Interface.** Displays the encoded telegram resulting from the above operation and the encoded telegram loaded from a file by the “Printout/File Interface”.
- **Printout/File Interface.** Prints the encoded telegram, or stores/loads it to/from a file.

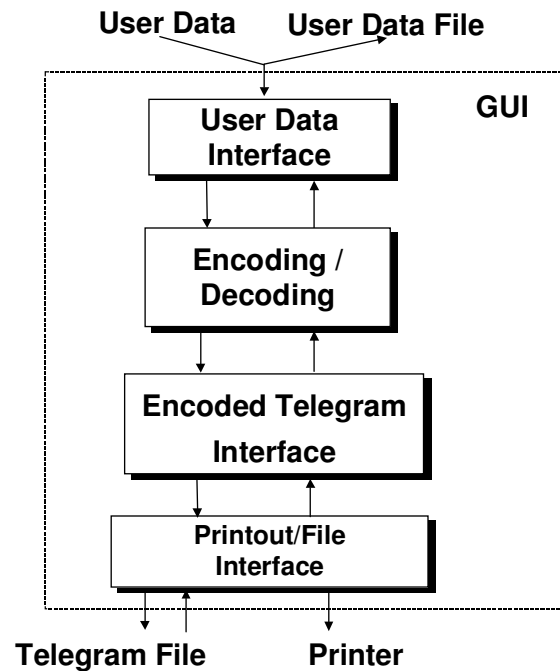

Figure 67: Functional Architecture of the OLTG

D4.3 External Interfaces

D4.3.1 User Data

D4.3.1.1 General

User Data interfacing should be provided on various levels:

1. High level description using packets and variables according to ERTMS/ETCS language.
2. Using hexadecimal representation of User Bits.

Interfacing by means of information from file, and interactive interfacing via the MMI should be supported.

The OLTG should provide handling of several consecutive telegrams stored within the same file.

D4.3.1.2 Packet and variables representation

User Data is entered and displayed in accordance with the packets and the variables defined by the ERTMS/ETCS language. During interactive input (i.e., not from file), some variables are possible to automatically determine. This should be supported by the OLTG. Automatic padding (with “ones”) should be supported when required.

D4.3.1.3 Hexadecimal representation

In this case the representation should be in accordance with the format of Table 20 in sub-clause A2 on page 129.

D4.3.2 Telegram File

The OLTG should provide encoded telegram data consistent with the input User Data. This encoded data should be stored on file and displayed via the Graphical User Interface.

Additionally, the OLTG should be able to provide decoded User Data, based on encoded telegrams (from file). This decoded data should be stored on file and displayed via the Graphical User Interface.

The format of the encoded telegram file should be in accordance with the representation exemplified in Table 22 in sub-clause A2 on page 131.

D4.3.3 Printout

The OLTG should support printing of all relevant input and output information.

D5 Description of Test Management System (LTMS)

D5.1 Operational Context

The LTMS is in charge of automatic control and management of the Eurobalise laboratory tests regarding track-side Balise, On-board Transmission Equipment, and overall transmission systems (combinations of Balises and On-board Transmission Equipment). It controls all the instruments and the tools required for a given test procedure, collects and analyses the relevant measurement data, and summarises the test results in final Test Bulletins.

A simplified context diagram for the tool is given in Figure 68. It shows the external interfaces used for commands and data exchange with the controlled equipment. The commands are specific for each controlled device. The exchanged data is generally of two distinct types. One is configuration settings exchanged at the start up of a test procedure. The other is on-line raw test data resulting from the execution of the test routines.

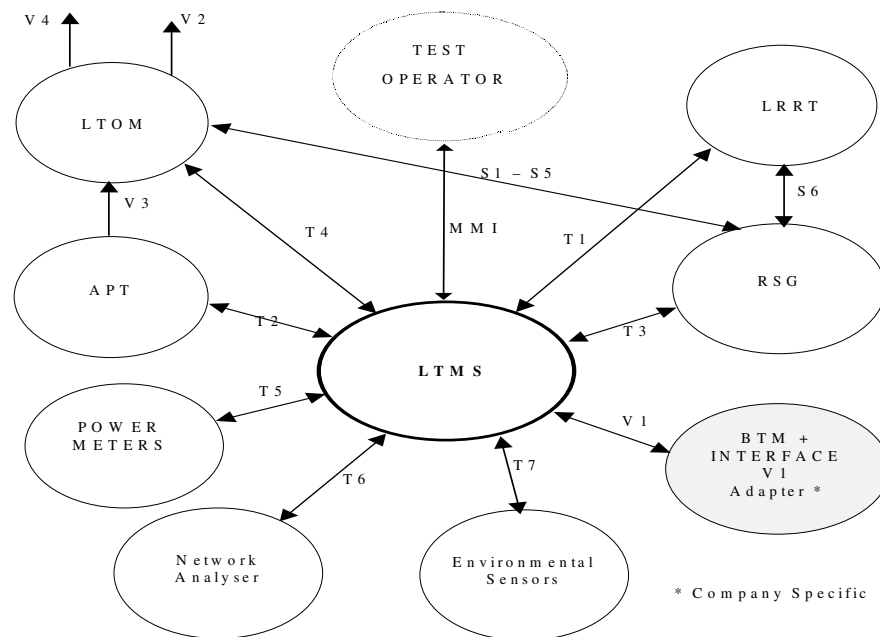

Figure 68: LTMS operational context

The tool interacts with the Test Operator, via a Graphical Man Machine Interface, for all the needs of personalisation, control, and monitoring of the test procedures.

The tool fulfils the following basic operations:

- Guiding the operator during the preparation of the test set-up and displaying the progress status of the test procedure as well as the results of the current step.
- Controlling the APT for getting the positions required for each test step.
- Controlling the LTOM for the current speed measurement, or simulation, as well as for initial settings and synchronisation.
- Controlling the RGS for simulating the required signals at Interface 'A' and/or at Interface 'C'.
- Controlling the LRRT, the Power Meters, and the Network Analyser for measuring the characteristics of the signals at Interface 'A' or at Interface 'C'.
- Controlling the operational mode of the Antenna/BTM functionality under test, and collecting the relevant test data.
- Controlling the environmental sensors for periodical measurements of ambient temperature and humidity within the test bed.
- Analysing and checking the correctness of the measurement results.
- Recording results and conditions of each test step in a structured way, and printing of the summary Test Bulletins.

D5.2 Functional requirements

D5.2.1 Basic Functions

The LTMS is used for automatic management of those procedures that require long sequences of elementary test steps.

The LTMS is basically composed of a Personal Computer equipped with I/O Interface Boards, for interfacing the tools and the instruments indicated in Figure 68. Such tools and instruments typically perform the front-end functions required for each test procedure, which can generically be distinguished in generation of input signals for the equipment under test and measurement of its output signals. The LTMS co-ordinates the operation of such instruments according to the needs of each test procedure, and records in a structured way all the relevant data.

The operator controls the operational mode of the tool. In particular, he commands the start or the abortion of a defined test sequence. The tool provides an on-line operational guide to the operator when manual intervention is required during the progress of the test. Visual or acoustic warnings are issued in order to alert, in case of critical occurrences or when a manual intervention is needed.

Specific self-tests of the various interconnected tools may be invoked for allowing procedures for re-calibration or trouble-shooting.

The tool should perform, in various combinations, the following basic functions:

- Support to editing, debugging and personalisation of the test procedures.
- Interfacing with the Test Operator.
- Interfacing with the RSG.
- Interfacing with the APT.
- Interfacing with the LTOM.

- Interfacing with the LRRT.
- Interfacing with Power Meters.
- Interfacing with the Network Analyser.
- Interfacing with the BTM functionality.
- Interfacing with the temperature and humidity sensors.
- Interfacing with the software tool that handles and stores the raw test data and produces the summary Test Bulletins.
- Closed-loop control of the Up-link current level.
- Closed loop control of the Tele-powering current level.
- Execution of an expandable set of pre-compiled test procedures.

D5.2.2 Operational Modes

D5.2.2.1 General

In order to ensure flexibility of use, combined with guarantee of correct handling of the test results, the LTMS should allow a selective operator access, via a suitable password handling, to the editing and the updating resources of the tool.

The tool should allow the following possibilities for a generic operator:

- Logging-in for entering basic information regarding Test Operators and Test Set-up that are reported in the Test Bulletins.
- Open/Close a given test procedure.
- Start the execution of a pre-selected test procedure.
- Abort the execution of the test procedure in execution.
- Restart the execution of a given test procedure from the step at which it was possibly interrupted.

For authorised operators the following additional possibilities should be allowed:

- Editing a test procedure by introducing pauses, deletion, replacement, insertion or skip of individual test steps.
- Updating input data for a given test procedure.
- Step by step execution of the test procedure for troubleshooting purposes.

D5.2.2.2 Idle and self-test mode

This is the default mode of the tool at power on or at the conclusion of a given test procedure. In this mode, all the controlled tools should be kept inactive. The local control condition should be enabled for each of them and their outputs set to a safe status.

Under command of the operator, the tool should allow the individual verification of correct behaviour of the external interfaces and of the interconnected tools and instruments.

D5.2.2.3 Test procedure control

D5.2.2.3.1 Conformity tests for Reference Loops

The mutual impedance between two Reference Loops of the same typology is measured in a number of different reciprocal positions during free space conditions. The measurements are compared with the expected data that are derived both from theoretical evaluations and from analogous measurements on validated Reference Loops. In these measurements, the LTMS is required to control:

- The APT for locating one of the two Reference Loops under test in the required test positions.
- The Network Analyser, with S-parameter Test Set, for generation of the input test signal and for measurement of the respective test output.
- The software tool for handling and storing the test data, as well as for checking the fulfilment of the conformity requirements, and for evaluating the Reference Loop compensation factors (B factor see sub-clause H2.4 on page 315).

The procedure applies to both typologies of Reference Loops (i.e., Standard and Reduced sizes), and to both transmission channels (i.e., Up-link transmission and Tele-powering).

D5.2.2.3.2 Calibration measurements for Balise tests

D5.2.2.3.2.1 Tele-powering flux

These measurements provide basic reference data from the combined use of the Test Antenna, which generates the Tele-powering field in the air-gap, and of the Reference Loop that receives the concatenated flux. The resulting test data is a set of values for the 27 MHz current to be driven into the Test Antenna in order to get a given concatenated flux into the Reference Loop, for all required positions of the Test Antenna and for all debris conditions over the Reference Loop. The recorded values are used for checking, by comparison, the transmission properties of the Balise in the same test conditions.

The following tools are controlled by the LTMS for this test:

- The APT for locating the Test Antenna very accurately to the required test positions referred to the centre of the Reference Loop. Two main zones of the test bed are involved in this test: “Main Lobe Zone” and “Side Lobe Zone”.
- The RSG for generating a controlled current into the Test Antenna in order to get a defined flux level into the Reference Loop. The flux level is measured indirectly by means of a Power Meter connected at the Reference Loop output. The LTMS closes the control loop of the 27 MHz current including RSG, Test Antenna, Reference Loop, and Power Meter.
- The Power Meter for measuring the current level entering into the Test Antenna and the output power delivered by the Reference Loop for each test condition.
- The Environmental Sensors for measuring, at regular intervals, the ambient temperature and humidity near the test bed.
- The software tool for handling and storing the Tele-powering calibration data that are used by other Balise test procedures.

D5.2.2.3.2.2 Up-link Balise signal

These measurements provide basic reference data from the combined use of the Reference Loop, which generates the Up-link field in the air-gap, and of the Test Antenna that receives a signal induced at its receiving coil. The resulting test data is a set of values for the Up-link power received by the Test Antenna for all the required test positions and debris types over the Reference Loop, when a given Up-link current is driven into the same Reference Loop. The recorded values are used for checking, by comparison, the transmission properties of the Balise in the same test conditions.

The following tools are controlled by the LTMS for this test:

- The APT for locating the Test Antenna in the same positions used for the Tele-powering flux measurements as well as in additional positions of the “Cross-Talk protected Zone”.
- The RSG for driving a controlled Up-link current into the Reference Loop. The current is measured by means of a probe whose output is read by the Power Meter. The LTMS closes the control loop of the 4.2 MHz current including RSG, Reference Loop, current probe, and Power Meter.
- The Power Meter for measuring the current entering into the Reference Loop as well as the Up-link signal received by the Test Antenna at each test condition.
- The Environmental Sensors for measuring, at regular intervals, the ambient temperature and the humidity near the test bed.
- The software tool for handling and storing the Up-link calibration data that are used by other Balise test procedures.

D5.2.2.3.3 **Balise Conformity tests**

D5.2.2.3.3.1 Tele-powering flux

The amplitude of the 27 MHz current, needed for concatenating a defined flux level with the Balise active area, is measured for each position of the Test Antenna. In such positions, the achievement of the desired flux level is indirectly verified by measuring the Up-link signal received, from the Balise under test, by a 4.2 MHz Antenna kept in a fixed central position. The results are compared with the Tele-powering calibration data determined for the applicable Reference Loop.

The following tools are controlled by the LTMS for this test:

- The APT for locating the Test Antenna at defined test positions referred to the centre of the Balise under test. The same test positions as those used for the Tele-powering calibration measurements are used for this test as well.
- The RSG for driving the Test Antenna with a 27 MHz current that produces the same Tele-powering flux that was used during the Tele-powering calibration phase for the same test condition. The LTMS closes the controlling loop of the 27 MHz current including RSG, Test Antenna, Current Probe, and Power Meter.
- The Power Meter for measuring the 27 MHz current entering into the Test Antenna and the Up-link signal received, from the Balise under test at each test condition, by the 4.2 MHz Antenna.
- The Environmental Sensors for measuring, at regular intervals, the ambient temperature and the humidity near the test bed.
- The software tool for handling and storing the Tele-powering conformity results and for checking the fulfilment of the respective requirements.

D5.2.2.3.3.2 Up-link signal

An Activation Antenna located in fixed position is driven by the RSG in order to power the Balise. Its input current is controlled in such a way as to concatenate a suitable Tele-powering flux into the Balise, producing the same Up-link signal that was measured during the Up-link calibration measurements with the Test Antenna in central position. Keeping the 27 MHz current constant during all other measurements, the Up-link signal received by the Test Antenna in all the test positions is measured and checked against the reference Up-link calibration data.

The following tools are controlled by the LTMS for this test:

- The APT for locating the Test Antenna very accurately in the same positions as those used for the Up-link calibration measurements.
- The RSG for driving the Activation Antenna with a controlled 27 MHz current that produces the same Up-link signal as in the calibration phase with the Test Antenna in central position. The LTMS closes the control loop of the 27 MHz current including RSG, Activation Antenna, Test Antenna, and Power Meter. When applicable, the RSG is also controlled for generation of the Interface 'C' signals, presenting the required electrical characteristics and carrying the chosen test telegram.
- The Power Meter for measuring the current level entering into the Activation Antenna and the Up-link signal received, from the Balise under test, by the Test Antenna at each test condition.
- The Environmental Sensors for measuring, at regular intervals, the ambient temperature and the humidity near the test bed.
- The software tool for handling and storing the Up-link conformity results and for checking the fulfilment of the respective requirements.

D5.2.2.3.4 **Input to Output Characteristics**

The Test Antenna that is driven by the RSG with a suitable 27 MHz current, corresponding to different flux levels, is used for powering the Balise. The Up-link signal received by the same Test Antenna is measured and recorded for each flux level condition. The flux levels are determined on the basis of Tele-powering calibration measurements giving, for the actual position of the Test Antenna and for a known flux level, the 27 MHz current to be driven into its Tele-powering coil. The measured Up-link signal power is translated into Up-link current encircling the applicable Reference Area on the basis of the Up-link calibration measurements. The set of recorded values of flux level versus the corresponding Up-link signal current is used for plotting the Balise I/O characteristics. The software tool for handling and storing the I/O characteristic results is also used for checking the fulfilment of the respective requirements.

The same tools of the Up-link conformity tests are controlled by the LTMS also for this test with the exception of the Activation Antenna that is replaced by the activation coil of the Test Antenna. This test is performed only at the central position of the Test Antenna.

D5.2.2.3.5 Electrical characteristics of the Up-link signal

The electrical characteristics of the Up-link signal are evaluated in the elementary test steps listed hereafter. The Test Antenna powers the Balise, to the required flux levels, from its central position for all the test steps. The Up-link signal received by the same antenna is processed by the LRRT and the final test results are stored and formatted by the LTMS.

The following characteristics of the Up-link Balise signal are verified, both in static and in dynamic, simulated conditions:

- Centre frequency and frequency deviation.
- Mean data rate.
- Maximum time interval error (MTIE).
- Amplitude jitter.
- Signal bandwidth.
- Balise start-up behaviour.
- Balise behaviour in “non-toggling” Tele-powering mode.
- Time delay between Interface ‘C’ data signal and air-gap Up-link signal.
- Blocking signal at Interface ‘C’ during the Balise start-up.

The same characteristics of the Up-link Balise signal are verified, in different conditions, regarding to the Interface ‘C’ signals:

- Nominal and worst case electrical characteristics of the Interface ‘C’ signals.
- Different Return Loss conditions.
- Transient failure conditions for the Interface ‘C’ signals leading to the transmission of the default telegram.

The following tools are controlled by the LTMS for this test:

- The APT, the RSG, The Test Antenna, and the Power Meter in a similar way as for the Balise I/O Characteristic tests.
- The RSG for generating the required signals at Interface ‘C’, with the required electrical characteristics, and carrying the required test telegram.
- The LRRT for processing and checking the characteristics of the Up-link signal received by the Test Antenna, in order to get final test data for LTMS recording and formatting.
- The Environmental Sensors for measuring, at regular intervals, the ambient temperature and the humidity near the test bed.

D5.2.2.3.6 Tele-powering radiation patterns for the On-board equipment

This test consists in determining the level of Tele-powering flux concatenated with the applicable Reference Loop when the antenna under test is kept still in defined positions along the longitudinal direction, with different vertical, lateral and angular displacements. The test should be organised in such a way as to cover the different areas of the test bed: “main lobe zone”, “side-lobe zone” and “cross-talk protected zone”.

The output 27 MHz power from the Reference Loop, measured in correspondence to a given position of the antenna under test, is used for the evaluation of the corresponding concatenated flux level. The set of flux levels measured along the longitudinal direction within the main lobe zone is used for generating distance-based radiation diagrams of the antenna that are used for the transmission tests. The measurement results in the cross-talk and side-lobe zones are used for the evaluation of the physical cross-talk protection margins of the On-board equipment.

The following tools are controlled by the LTMS for this test:

- The APT for positioning the Antenna under test in the required positions over horizontal planes of the test bed referred to the centre of the Reference Loop.
- The LTOM for providing the BTM function with the current time and odometer information consistent with the antenna movement.
- The Interface V1 Link, for controlling the required operational mode of the BTM function and for collecting the reported test data.
- The Power Meter for measuring the 27 MHz power delivered by the Reference Loop in correspondence of the various positions of the antenna under test.
- The Environmental Sensors for measuring, at regular intervals, the ambient temperature and the humidity near the test bed.
- The software tool for handling and storing, for each tested condition, the Tele-powering flux values together with the corresponding geometrical co-ordinates of the antenna under test. Such data are used by other test procedures regarding the On-board equipment.

D5.2.2.3.7 Up-link radiation pattern for the On-board equipment

The test consists in determining, for each position of the antenna under test, the 4.2 MHz current level that is needed in the applicable Reference Loop for reaching the threshold level of the BTM receiver functionality. The correct signal detection is evaluated from observation of the BTM function data reported at the Interface V1. The test requires simplified simulation of Balise passages at a given constant speed, with controllable Up-link current driven into the Reference Loop. For each position, the Up-link current is increased from zero up to the level at which the BTM function is able to correctly receive the transmitted Up-link data. The set of Up-link threshold currents measured along the longitudinal direction within the main lobe zone is used for generating distance-based reception diagrams of the antenna that are used for the transmission tests. The measurement results in side-lobe and cross-talk zones are used for the evaluation of the physical cross-talk protection margins of the On-board equipment.

The LTOM is controlled consistently with the simulated Balise passages, both during each measurement phase and outside the measurement, in order to respect normal constraints about real or simulated speed conditions and the minimum distances allowed between consecutive Balises and Balise groups.

The test is performed for the same longitudinal positions used for the Tele-powering radiation diagrams and for the same lateral, vertical and angular displacements.

The following tools are controlled by the LTMS for this test:

- The APT for positioning the Antenna under test in the same positions as those used for the Tele-powering radiation diagrams.
- The LTOM for providing the BTM function with the current time and odometer information consistent with the real and the simulated antenna movements.
- The Interface V1 Link, for controlling the required operational mode of the BTM function and for collecting the reported test data.
- The RSG for providing an Up-link FSK current burst, carrying the required test telegram, with controlled amplitude and dynamic characteristics.
- The Power Meter for measuring the Up-link current level in the Reference Loop, during the initial calibration phase.
- The Environmental Sensors for measuring, at regular intervals, the ambient temperature and the humidity near the test bed.
- The software tool for handling and storing, for each tested condition, the Up-link threshold current together with the corresponding geometrical co-ordinates of the antenna under test. Such data are used by other test procedures regarding the On-board equipment.

D5.2.2.3.8 Transmission tests for the On-board equipment

This test consists in simulating, by the use of the RSG and the applicable Reference Loop, a dynamic Up-link Balise signal, according to the requirements of each test scenario, while keeping the antenna under test in a fixed central position. The time envelope of these signals as well as its electrical characteristics and the carried data telegram is generated by the RSG for each test condition (off-line) before running the tests. The correct behaviour of the On-board equipment under test is assessed on the basis of the BTM function data reported at the Interface V1.

In general the test consists in simulating a “virtual test line” with Balises located in pre-defined realistic positions. Different test telegrams, representing realistic application cases, are used for the different Balise simulations. The various test scenarios are organised in order to verify the achievable transmission performance (“contact length” or “contact time” or “number of received valid telegrams”) in combination with different operational conditions including:

- The two different types of Reference Loops and the relevant installation conditions.
- The applicable mode of Tele-powering (CW or Toggling).
- The speed regime (from standing still to the maximum allowed speed).
- The installation conditions for the antenna.
- The worst case combination of debris conditions.
- The quality of the Up-link Balise signal (electrical characteristics).
- The possible Balise layouts (Balise sequences within a group).
- The typology of data and of Balise telegrams.
- The presence of data error conditions in the telegrams.

The signal patterns, corresponding to a complete test scenario, are evaluated and pre-loaded into the RSG for their real-time handling during the initial configuration phase of the scenario itself.

The LTMS controls the LTOM for simulation of the required speed pattern during the whole “test trip” as well as for triggering the RSG for starting the Balise signal simulations at the exact time and odometer co-ordinates required by the test scenario.

All the BTM function reports at Interface V1 are checked against the expected results and reported with all information about test conditions, in the final Test Bulletins.

The following tools are controlled by the LTMS for this test:

- The APT for positioning the antenna under test in a fixed central position.
- The LTOM for simulating the required distance-based speed pattern and for generating the time and odometer information for the BTM function consistently with the simulated speed. It also issues triggering pulses to the RSG for the generation of the relevant Balise signal, according to pre-defined distance-based Balise layouts.
- The RSG for providing the Up-link FSK signal, emulating the required test telegrams, with accurately controlled amplitude envelope and electrical characteristics.
- The Interface V1 Link for controlling the required operational mode of the BTM function and for collecting its reported data.
- The Power Meter for measuring the 4.2 MHz current level into the Reference Loop during the initial calibration phase.
- The Environmental Sensors for measuring, at regular intervals, the ambient temperature and the humidity near the test bed.
- The software tool for handling and storing, for each tested condition, the set of reported Up-link telegram data, the respective Balise location data, and the number of received telegrams for each simulated Balise passage. Such data are used for off-line evaluation of the achievable transmission reliability performance of the On-board equipment.

D5.3 External Interfaces

D5.3.1 Man Machine Interface (MMI)

The Man Machine Interface should allow the operator to perform, in an easy way, the following actions:

- To recall one or more test procedure from the set of pre-compiled ones.
- To support the updating of the test step sequence of a given procedure to better fit to the specific needs of the test set-up (e.g. introduction of break points, skipping or insertion or replacement of specific steps).
- To save any newly updated test procedure.
- To personalise the actual test cases of interest with input data provided directly by the operator (e.g. lateral or vertical displacement of the On-board antenna).
- To choose the applicable values for the input parameters required for a specific test procedure.
- To command the step by step execution of the test procedure.
- To command the full execution of the test procedure.
- To abort the on going execution of the test procedure.
- To re-start an interrupted procedure from the test in which it was possibly interrupted.
- To follow the current status and the regularity of execution of the on-going test as well as the summary of the test results in progress.

D5.3.2 Interface V1

The Interface V1 regards commands and data exchange between the LTMS and the On-board equipment under test.

The dialog over this interface is mastered by the LTMS for commands issued by the LTMS. As far as the reports of the On-board equipment to the LTMS are concerned, the dialog can be started by the BTM function at any time, independently from the LTMS status. The LTMS should guarantee that no reported data is lost even when it is occasionally occupied in long general management tasks. More details on the exchanged commands and data and can be found in clause E1 on page 275.

D5.3.3 Interface T1

The interface T1 regards commands and data exchange between the LTMS and the LRRT.

The dialog over this interface is always mastered by the LTMS. The LRRT only answers to LTMS when requested. More details on the exchanged data can be found in sub-clause D6.3.1 on page 272.

D5.3.4 Interface T2

The interface T2 regards commands and data exchange between the LTMS and the APT.

The dialog over this interface is always mastered by the LTMS. The APT only answers to LTMS when requested. More details on the exchanged data can be found in sub-clause D3.3.1 on page 238.

D5.3.5 Interface T3

The interface T3 regards commands and data exchange between the LTMS and the RSG.

The dialog over this interface is always mastered by the LTMS. The RSG only answers to LTMS when requested. More details on the exchanged data can be found in sub-clauses D2.3.1.1 on page 229, D2.3.2.1 on page 229, and D2.3.3.1 on page 230.

D5.3.6 Interface T4

The Interface T4 is used to exchange commands and data between the LTMS and the LTOM.

The dialog over this interface is always mastered by the LTMS. The LTOM only answers to LTMS when requested. More details on the exchanged data can be found in sub-clause D1.3.1 on page 218.

D5.3.7 Interface T5

The Interface T5 is used to exchange commands and data between the LTMS and the Power Meter.

The dialog over this interface is always mastered by the LTMS. The Power Meter only answers to LTMS when requested. More details on the exchanged data can be found in the instrument user manuals.

D5.3.8 Interface T6

The Interface T6 is used to exchange commands and data between the LTMS and the Network Analyser.

The dialog over this interface is always mastered by the LTMS. The Network Analyser only answers to LTMS when requested. More details on the exchanged data can be found in the instrument user manuals.

D5.3.9 Interface T7

The Interface T7 is used to exchange commands and data between the LTMS and the Temperature and Humidity Sensors.

The dialog over this interface is always mastered by the LTMS. The sensors only answer to the LTMS when requested. More details on the exchanged data can be found in the sensor user manual.

D5.4 Required Performance

The following performance is required to the basic functions of the LTMS:

- The tool must allow for uninterrupted test procedures lasting from few minutes to about 20 hours.
- The reaction time of the tool to test related events should not exceed 0.2 s, during normal conditions, when the management of the on-going test procedure is the main task of the tool. This reaction time can sporadically be extended to 1 s to 2 s when the test procedure is managed in coincidence with other general tasks of the tool. Sufficient provisions should be put in place in such case in order not to lose incoming test data or inputs of any kind.
- The memory capability of the tool should guarantee that no test related data (e.g., the data reported from the BTM function via the Interface V1) is lost during the admitted latency time of the tool.
- In order to minimise the test time regarding long repetitive procedures, the overall closed loop operations regarding Up-link or Tele-powering current adjustment should be done within a maximum time of 2 s.
- The recording of the test related data should be suitably protected after test corruption or manipulation of any kind.

D6 Description of Reference Receiver Tool (LRRT)

D6.1 Operational Context

The LRRT is used for analysing the electrical characteristics of the signals exchanged between Eurobalise units (track-side Balise and On-board equipment) and tools at their standard interfaces (i.e., Interface ‘A’ and Interface ‘C’), in order to verify the fulfilment of the relevant requirements.

The analysis is typically done off-line, after memorising a defined time record of the signal under test. The main characteristic of this tool is that the signal acquisition and its first level analysis (e.g., demodulation) is performed whenever is possible by commercial instruments used as front-end RF devices. When this is not practically possible, the tool itself performs specific signal analysis algorithms.

A context diagram of the laboratory test environment involving the LRRT is given in Figure 69.

According to the actual test step, the signals submitted to the LRRT analysis can be:

1. The Up-link signal A1 that is generated by the Balise under test and is picked up by the Test Antenna. For purposes of calibration of the set-up, the Up-link signal A1 may also be generated by the RSG, transmitted in the air-gap via the Reference Loop and picked up by the Test Antenna;
2. The Tele-powering signal A4 that is generated by the On-board equipment under test and is picked up by the Reference Loop. For purposes of calibration of the set-up, the Tele-powering signal A4 may also be generated by the RSG, transmitted in the air-gap via the Test Antenna and picked-up by the Reference Loop;
3. The Interface ‘C’ signals (data signal C1 and biasing signal C6) measured over the respective reference resistive loads, and the blocking signal C4, received via a suitable current/voltage probe from the Balise under test during its start-up transient.

In order to allow fast verification of the test set-up, or to run simplified tests, the LRRT can be controlled in local mode, via a graphical Man Machine Interface (MMI), by the Operator.

The LRRT is controlled, in remote mode, by the LTMS by exchange of data and commands via the Interface T1. In dynamic simulated test cases, the tool receives fast triggering signals from the RSG (Interface S6) for starting the measurements at suitable instants, correlated with the RSG output signals.

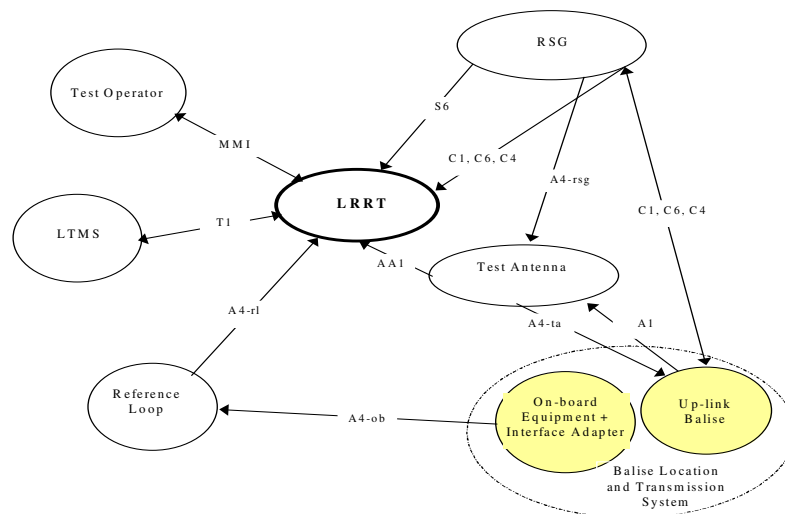

Figure 69: LRRT operational context

D6.2 Functional Requirements

D6.2.1 Basic Functions

The tool performs the following basic functions that correspond to distinct or to overlapping operational modes.

The basic functions of the LRRT are:

1. Interfacing with the Test Operator via the MMI.
2. Interfacing with the LTMS via the Interface T1.
3. Performing all the required verifications of the electrical characteristics of the Up-link signal (A1) generated by the Balise under test, using the test antenna.
4. Performing all the required verifications of the electrical characteristics of the Tele-powering signal (A4) generated by the on-board equipment under test.
5. Performing all the required verification of the electrical characteristics of the Interface 'C' signals generated both by the LEU (C1 and C6 signals shall be monitored at the LEU end of the Interface 'C' cable) and by the Balise under test (C4).

For each operational mode, the tool performs one, or a combination of, the following elementary functions:

- Sampling the input signal with adequate sampling rate and recording of a signal record with the required duration, time and frequency resolution, and accuracy.
- Performing spectral or modulation analysis of the recorded signal in the required frequency range with different levels of frequency resolution.
- Performing frequency-based separation of signals simultaneously present on the same medium.
- Performing different kinds of demodulation on the recorded signal, either for reconstructing the intentional modulating signal or for verifying the fulfilment of other requirements.
- Extracting additional information (e.g., modulation clock reconstruction) from the demodulated signal, necessary for the complete signal analysis.
- Performing a logical analysis on the extracted data.
- Performing self-check routines for verification of correct insertion of the front-end instruments required for a given test set-up.
- Implementing the commands of the LTMS and reporting back the measurement results.
- Displaying the measurement results with reference to the relevant tolerance ranges.

The LRRT is basically composed of a Personal Computer controlling commercial instruments that perform the required front-end functions of signal acquisition and preliminary analysis.

The LRRT performs some specific analysis on the acquired signals that are not possible with general purposes commercial instruments. Finally, it checks the achieved performance versus the respective requirements and formats the results for a friendly presentation to the Operator.

The following list gives a set of commercial front-end instruments needed for the complete set of required verifications:

- A Vector Signal Analyser for acquisition, spectral analysis and demodulation of the Up-link signal A1.
- A Spectrum Analyser for the evaluation of the frequency characteristics of the Tele-powering signal A4 and of the Biasing signal C6 of the Interface 'C'. It may also be used for the evaluation of Return Loss of the biasing signal in Interface 'C6'.
- A Digital Storage Oscilloscope for the evaluation of some time characteristics of the Tele-powering signal A4, of the data signal C1, of the Biasing signal C6, and of the Blocking signal C4 of the Interface 'C'.
- A Network Analyser for the evaluation of the Return Loss of the Data signal C1, and of the Biasing signal C6 of the Interface 'C'.

D6.2.2 Operational Modes

D6.2.2.1 Idle and self-test mode

This is the default mode of the tool at power on or at the conclusion of a given test procedure. In this mode, all the controlled instruments should be kept or restored to their local control.

Under command of the Operator, the tool should allow the individual verification of correct behaviour of the external interfaces and of the interconnected instruments.

D6.2.2.2 Up-link signal analysis (LRRT_1)

D6.2.2.2.1 General

The Up-link signal A1 is read from the receiving loop of the Test Antenna, is pre-analysed by the Vector Signal Analyser, and is finally processed and checked by the LRRT function LRRT_1 with reference to the applicable requirements.

D6.2.2.2.2 Signal power

The Vector Signal Analyser, under proper control of the LRRT_1 functionality, evaluates the power of the Up-link signal within the frequency band of interest. The instrument should be configured as a scalar spectrum analyser for this measurement. Additionally, it should be possible to set the "centre frequency" within the range of 4.24 MHz \pm 1.5 MHz, the "frequency span" between 0.8 MHz and 8.0 MHz, the "frequency resolution" between 10 Hz and 10 kHz, and the "averaging factor" between 1 and 10.

D6.2.2.2.3 Signal bandwidth

The signal bandwidth verification of the Up-link signal is performed by the LRRT_1 functionality on the basis of three signal power measurements, performed by means of the Vector Signal Analyser as mentioned above. The power at the centre frequency of the signal, measured within a span of 1 MHz, is compared with the power, measured at \pm 1 MHz from the centre frequency with the same 1 MHz span.

This test should be preceded by evaluation of the average centre frequency of the actual Up-link signal under consideration.

D6.2.2.2.4 Centre frequency and frequency deviation

The centre frequency and the frequency deviation of the Up-link signal are evaluated on the basis of a phase demodulated signal record provided by the front-end Vector Signal Analyser.

The following settings of the Vector Signal Analyser should be possible:

- Analogue phase demodulation.
- Centre frequency selectable between 4.0 MHz and 4.5 MHz.
- Frequency span selectable between 1.0 MHz and 8.0 MHz.
- Time duration of the recorded signal selectable between 1 ms and 4 ms.

This test should be preceded by evaluation of the average centre frequency of the actual Up-link signal under consideration. This average centre frequency is then used for the required setting of the analogue phase demodulation.

Both static and dynamic simulated conditions should be allowed. For the last one, the signal acquisition and analysis should be started immediately after an external trigger pulse.

The LRRT_1 functionality should perform the following additional analysis over the demodulated data from the Vector Signal Analyser:

- Detection of the exact time intervals corresponding to each demodulated symbol (clock recovery).
- Linear fitting of the phase demodulated signal over each symbol duration and evaluation of the corresponding average centre frequency and frequency deviation.
- Evaluation of the centre frequency and frequency deviation by searching worst case combinations of maximum and minimum bit frequency within a sliding window.
- Verification of compliance with the relevant centre frequency and frequency deviation requirements.

D6.2.2.2.5 Mean data rate

The mean data rate of the Up-link signal is evaluated by the LRRT_1 functionality on the basis of data provided by the front-end Vector Signal Analyser configured as Analogue Phase Demodulator. For other settings, the Vector Signal Analyser should be configurable in a similar way as for the centre frequency and frequency deviation test, both in relation to static conditions and to dynamic simulated ones.

This test should be preceded by evaluation of the average centre frequency of the actual Up-link signal under consideration. This average centre frequency is then used for the analogue phase demodulation.

The LRRT_1 functionality should perform the following additional analysis over the demodulated data from the Vector Signal Analyser:

1. Linear fitting of the phase demodulated signal and detection of the exact instants of symbol transitions.
2. Identification of the exact time interval corresponding to each symbol by splitting the time between two consecutive transitions into an integer number of symbols.
3. Evaluation of the time duration corresponding to a defined number of consecutive symbols (selectable between 100 and 2000 symbols) starting at any possible symbol transition within the stored record.
4. Evaluation of the average data rate over the defined bit sequence.
5. Shift of the bit sequence by a pre-defined number of bits (expressed in percentage of overlapping with the previous window, selectable between 1% and 100%) and repetition of steps 4 and 5 until the whole duration of the acquired signal is analysed.

6. Verification of fulfilment of the data rate requirement for all evaluated sequences and printout of the final average data rate over the analysed signal record.

D6.2.2.2.6 Maximum Time Interval Error – MTIE

Both typologies of MTIE verifications (i.e. MTIE1 and MTIE2) allowed for the Up-link signal should be supported. The MTIE verifications are performed by the LRRT_1 functionality on the basis of data provided by the front-end Vector Signal Analyser configured as Analogue Phase Demodulator. For other settings, the Vector Signal Analyser should be configurable in a similar way as for the centre frequency and frequency deviation test, both in relation to static conditions and to dynamic simulated ones.

This test should be preceded by the evaluation of the average centre frequency of the actual Up-link signal under consideration and by the Mean Data Rate verification. This average centre frequency is then used for the analogue phase demodulation. The Mean Data Rate is used for the MTIE2 verification.

The LRRT_1 functionality should perform the following additional analysis over the demodulated data from the Vector Signal Analyser:

1. Linear fitting of the phase demodulated signal and detection of the exact instants of symbol transitions.
2. Identification of the time interval corresponding to each symbol on the basis of the reconstructed symbol transitions as well as on the reference average data rate that is the nominal Balise data rate for the MTIE1 verification, or the previously measured average data rate for the MTIE2 verification.
3. Evaluation of the time jitter for each reconstructed symbol with reference to the reference data rate. The overall time error evaluated between two subsequent symbol transitions is equally shared among all the equal symbols included between them.
4. Evaluation of the maximum time error of each symbol duration within an observation window of variable length (ranging between 1 symbol up to the half of the maximum window length). The initial position of this observation window is shifted bit by bit from the first bit of the analysed window, up to its last bit minus the actual length of the observation window.
5. Verification of fulfilment of the MTIE requirement for all evaluated observation windows and print-out of the final pattern of evaluated MTIE data versus the respective length of the observation window.

D6.2.2.2.7 Amplitude jitter

The verification of the amplitude jitter, possibly present over the Up-link signal, is performed by the LRRT_1 functionality on the basis of data provided by the front-end Vector Signal Analyser configured as Analogue Amplitude Demodulator. For other settings, the Vector Signal Analyser should be configurable in a similar way as for the centre frequency and frequency deviation test, both in relation to static conditions and to dynamic simulated ones.

The LRRT_1 functionality should perform the following additional analysis over the amplitude-demodulated data from the Vector Signal Analyser:

1. Evaluation of the average (RMS) amplitude of the demodulated signal within an observation window of duration selectable between 50 μs and 800 μs and within a shorter window of 1.77 μs duration at its centre. The amplitude jitter expresses, in dB, the ratio between the signal amplitude averaged over the shorter window and the signal amplitude averaged over the longer observation window. This jitter evaluation is repeated for all possible longer successive windows, each one shifted by 1.77 μs from the previous one. The algorithm should cover with continuity the whole duration of the recorded signal.
2. Verification of fulfilment of the amplitude jitter requirement for all evaluated windows and printout of the final pattern of evaluated amplitude jitter versus the instant of each observation window centre.

D6.2.2.2.8 Delay time between Interface ‘C1’ and Interface ‘A1’

The time delay between the data carried by the Up-link signal and the corresponding data at the Balise Interface ‘C1’ is evaluated by the LRR1_1 functionality on the basis of data provided by the front-end Vector Signal Analyser configured as Analogue Phase Demodulator. For other settings, the Vector Signal Analyser should be configurable in a similar way as for the centre frequency and frequency deviation test, both in relation to static conditions and to dynamic simulated ones.

Delay evaluation refers to the Balise internal delay excluding the delay in the Interface ‘C’ cable.

This test should be preceded by the evaluation of the average centre frequency of the actual Up-link signal under consideration. This average centre frequency is then used for the analogue phase demodulation.

The Vector Signal Analyser should start acquisition and demodulation of the Up-link signal soon after receiving a triggering pulse generated by the RSG with a known time relation with an easily detectable symbol (“reference symbol”) of the stream transmitted to the Balise Interface ‘C1’. Additionally, during dynamic simulated tests, the RSG should be kept synchronised with the rising Tele-powering ramp, in order to get simultaneity of the Vector Signal Analyser trigger with the expected start-up of the Balise.

The LRR1_1 functionality should perform the following additional analysis over the phase-demodulated data provided by the Vector Signal Analyser:

1. Average data rate evaluation for the whole duration of the recorded signal.
2. Identification of the exact start and end time of each symbol, based the detected bit transitions.
3. Verification of correct correspondence between the symbols contained in a window of defined length (selectable between 100 and 1500 symbols) and the ones sent to the Interface ‘C1’.
4. Identification of the “reference symbol”, corresponding to the RSG acquisition trigger, evaluation of its delay with respect to the triggering instant, and verification of compliance with the corresponding requirement.

D6.2.2.2.9 KER compatibility

The correct answer of the Balise, when it is being energised by Tele-powering signal in “non toggling” mode, is evaluated by the LRR1_1 functionality on the basis of data provided by the front-end Vector Signal Analyser configured as Analogue Amplitude Demodulator. For other settings, the Vector Signal Analyser should be configurable in a similar way as for the centre frequency and frequency deviation test, both in relation to static conditions and to dynamic simulated ones. The Digital Storage Oscilloscope could alternatively be used for this verification.

The LRR1_1 functionality should perform the following additional analysis over the data provided by the Vector Signal Analyser:

1. Filtering the received signal over a defined bandwidth selectable between 0.5 MHz and 2.0 MHz.
2. Evaluation of the average amplitude of the demodulated signal in a moving window of defined length (1 μ s – 10 μ s) over the whole duration of the acquired signal.
3. Evaluation of the overall duration of possible Up-link signal bursts from the Balise for the entire duration of the acquired signal. Possible noise from the test equipment shall be disregarded. This can be done by comparison with what is received without the presence of the Balise.
4. Verification of fulfilment of the Up-link signal requirement with non-toggling Tele-powering and printout of the time pattern of the average amplitude of the Up-link signal.

D6.2.2.3 Tele-powering signal analysis (LRRT_2)

D6.2.2.3.1 Carrier frequency and phase noise in CW

The carrier frequency and its frequency noise are evaluated by the LRRT_2 functionality on the basis of measurement data provided by the Network Analyser configured as a Spectrum Analyser. The instrument evaluates the power spectrum of the Tele-powering signal with specific settings selected for the measurement. Such settings include centre frequency (typically set at the nominal Tele-powering frequency), frequency span (selectable between 10 kHz and 200 kHz around the centre frequency), bandwidth resolution (selectable between 1.0 Hz and 100 Hz).

Because of the high level of accuracy required for the carrier noise evaluation, it is necessary that the measurement be performed with minimised environmental noise within the frequency band of interest. When this is not possible, the measurement should be corrected for the background noise measured at the frequencies of interest, with all the transmitting equipment turned off but keeping the same geometry of the test set-up that is used during the carrier noise measurement.

The LRRT_2 functionality controls the following steps:

1. Noise pre-calibration measurement with the equipment under test switched off (if applicable).
2. Evaluation of the power spectrum of the Tele-powering signal with the chosen settings.
3. Post-calibration noise measurement with the equipment under test switched off (if applicable).
4. Verification of fulfilment of the carrier frequency requirement.
5. Evaluation of the carrier power and of the worst case power level within the chosen frequency span, outside a 20 kHz frequency band centred on the carrier frequency.
6. Evaluation of the carrier noise (dBc/Hz), after subtracting (if applicable) the environmental noise spectrum resulting from the averaging the spectra recorded during the pre and post calibration steps, from the Tele-powering power spectrum. A further scaling of the Tele-powering worst case noise power is needed in order to translate the measurement result from the chosen bandwidth resolution to the required 1 Hz resolution.
7. Verification of fulfilment of the carrier frequency and noise requirements and printout of the noise spectrum data obtained from the noise calibration steps and during the Tele-powering signal analysis.

D6.2.2.3.2 Toggling modulation frequency

The toggling modulation frequency of the Tele-powering signal is evaluated by the LRRT_2 functionality on the basis of measurement data provided by the Network Analyser configured as a Spectrum Analyser. The instrument evaluates the toggling modulation frequency by measuring the frequency of a selectable number of harmonics present in the power spectrum of the Tele-powering signal.

This verification should be based on the measurement of the frequency of a certain number of signal harmonics centred around the Tele-powering carrier frequency. In order to get enough accuracy, each harmonic frequency measurement should be based on an individual power spectrum evaluation performed with appropriate span and frequency resolution settings.

The LRRT_2 functionality controls the following steps:

1. Measurement of the frequency corresponding to the peak level of the power spectrum centred on a given nominal frequency of the signal harmonic under consideration.
2. Repetition of the step 1 for the desired set of signal harmonics under consideration.
3. Evaluation of the toggling frequency based on the average frequency distance between successive signal harmonics.
4. Verification of fulfilment of the toggling frequency requirement and printout of the whole set of measured harmonic frequencies.

D6.2.2.3.3 Pulse width, jitter, modulation depth, and overshoot

The time and amplitude characteristics of the toggling modulation pulses: time duration, off-edge jitter, modulation depth, and overshoot are elaborated and verified by the LRRT_2 functionality on the basis of a Telepowering signal record acquired by means of the Digital Storage Oscilloscope with a suitable sampling rate.

The LRRT_2 functionality performs the following analysis over the acquired signal record:

1. AM-demodulation based on the previously evaluated centre frequency.
2. Evaluation of the average pulse width and width deviation based on the analysis of the AM-demodulated signal.
3. Evaluation of the falling-edge jitter based on the previously evaluated modulation frequency and on the analysis of the AM-demodulated signal.
4. Evaluation of the modulation depth, individually for the short and long pulse (when toggling modulation), based on the analysis of the AM-demodulated signal.
5. Evaluation of initial and residual overshoot of the carrier amplitudes based on the analysis of the AM-demodulated signal.
6. Verification of fulfilment of the electrical characteristic requirement of the toggling signal and printout of the AM-demodulated signal as well as of whole set of evaluated characteristics.

D6.2.2.4 Interface 'C' signal analysis (LRRT_C)

D6.2.2.4.1 Electrical characteristics of the Interface 'C1' signal

The analysis of the electrical characteristics of the Interface C1 signal is performed by the LRRT_C functionality on the basis of a suitably long record of voltage acquired by the Digital Storage Oscilloscope over the reference resistor loading the LEU output.

The LRRT_C functionality performs the following evaluations over the acquired signal:

1. Separation, by frequency filtering, of the C1 signal from the C6 signal.
2. Scanning, sample by sample, the C1 signal in order to find its amplitude value just in advance of each signal transition. The set of values so obtained forms the basis for the verification of the requirements regarding maximum and minimum signal values.
3. DBPL decoding, applying to a selectable window of 1000-2000 symbols, and data rate evaluation and verification procedures similar to those used for the Up-link Balise signal. These procedures, supplemented by the narrow data rate tolerance constitute an indirect verification of correct DBPL coding as well.
4. Time jitter evaluation and verification over the same signal record used for the mean data rate verification. A recovered data clock is reconstructed on the basis of the evaluated mean data rate value. The time differences between the active edges of the recovered data clock and the actual zero crossing instants of the C1 signal are evaluated, after some iterations aimed at finding the best phase of the recovered clock that minimises the average value of such time differences. The maximum jitter value found among all the transitions of the analysed signal record is then verified versus the maximum jitter requirement.

D6.2.2.4.2 Return Loss of the Interface 'C1'

The Return Loss on the Interface 'C'1 is verified by the LRRT_C functionality on the basis of the measurement data provided by the Network Analyser, controlled according to the procedure described in sub-clause G1.4 on page 304.

D6.2.2.4.3 Electrical characteristics of the Interface 'C6' signal

The analysis of the electrical characteristics of the Interface 'C6' signal is performed by the LRRT_C functionality on the basis of a suitably long record of voltage acquired by the Digital Storage Oscilloscope over the reference resistor loading the LEU output.

The LRRT_C functionality, after filtering the C6 signal from the C1 signal, reconstructs the time pattern of the C6 signal amplitude by means of rectification, peak detection, and filtering performed over the acquired C6 signal record. The maximum and minimum values of the amplitude pattern are checked against the respective requirements.

The LRRT_C functionality verifies the frequency and the harmonic contents of the C6 signal on the basis of measurement data provided by the Network Analyser configured as Spectrum Analyser.

The frequency of the C6 signal should be measured from the Interface 'C' signal spectrum by using appropriate values of bandwidth resolution and frequency span that allow adequate frequency measurement accuracy and separation between the C1 and the C6 signal harmonics. The peak detection facility of the Spectrum Analyser should be used for detecting the fundamental frequency of the C6 signal.

In order to distinguish the higher order harmonics of the C6 signal from those of the C1 signal within the frequency range of interest, narrow span settings centred over exact multiples of the previously detected fundamental harmonic should be individually used for all possible higher harmonic frequencies. The overall harmonic contents should be finally evaluated for the entire region of interest by summing up the individual harmonics power and checked against the allowed limits, together with the individual content of the second harmonic.

D6.2.2.4.4 Return Loss of the Interface 'C6'

The Return Loss on the Interface 'C6' is verified by the LRRT_C functionality on the basis of the measurement data provided by the Network Analyser, controlled according to the procedure described in sub-clause G1.7 on page 307.

D6.2.2.4.5 Electrical characteristics of the Interface 'C4' signal

Records of suitable duration of the signals at the Balise Interface 'C' are acquired simultaneously by means of a High Vertical/Horizontal Resolution Digitiser Board. Acquisition is performed from a certain time in advance of a trigger pulse generated during the rising ramp of the Balise Tele-powering flux burst, at the instant of crossing over the ϕ_{d1} level.

The Interface 'C1' signal shall be a telegram constituted by an indefinite string of 'ones', which corresponds to a continuous square wave at 564.48 kHz. This means that all harmonics of the Interface 'C1' signal are above 564.48 kHz, so a low pass filter can easily filter them out. Additionally, the Interface 'C6' signal should be synthesized with sufficient vertical resolution (e.g., better than 12 bits) in order to minimise low frequency harmonics due to quantisation effects.

It is assumed that one polarity of the output of the RSG_C connected to the Balise terminal can be safely connected to the common ground of the signal-acquiring instrument.

Finally, it is assumed that a calibrated resistor of approximately 20 Ω , used for current sensing, can be connected in series with the hot terminal of the Balise without impairing the amplitude driving capabilities of the RSG_C.

The Interface 'C6' signal is separated from the corresponding Interface 'C1' signal via suitable low pass filtering both during the transient condition and during steady state conditions just before and after transient. The following applies:

- Fifth order Butterworth low pass filters (passive H/W) with 100 kHz cut-off frequency used for filtering out the Interface 'C1' signal, so allowing the digitiser board to use the best possible vertical resolution.
- Low pass FIR filters with "Top Flat Windowing" with 50 kHz cut-off frequency for filtering out the quantisation noise in the acquired signal.

The acquired signals are used for identification of a suitable linear circuit that model the behaviour of the input circuitry of the Balise during various instants of the explored transient.

In order to get good time resolution, this identification process must be performed within a very short sub-window (e.g., 40 μ s) and consecutively repeated many times in order to cover the entire transient duration.

The modulus of the identified circuit impedance at sinusoidal regime is evaluated for the minimum, the nominal, and the maximum frequency allowed for the Interface 'C6' signal (8720 Hz, 8820 Hz, and 8920 Hz). The identification algorithms are based on the pure differential equation describing two possible types of linear circuits used for modelling the input of the Balise (serial RL circuit or parallel RC circuit). Such algorithms provide the best approximation of serial RL or parallel RC circuits during the sinusoidal steady state condition preceding and following the impedance transient as well as during the transient condition.

The starting instant of the Interface 'C4' signal is defined as the instant at which the modelled input impedance of the Balise crosses down below the limit defined in UNISIG SUBSET-036 at the Balise end of the cable. This instant is used for determining the time delay from the triggering event of the signal acquisition.

The ending instant of the Interface 'C4' pulse signal is defined as the instant at which the modelled input impedance of the Balise steadily crosses over the limit defined in UNISIG SUBSET-036 at the Balise end of the cable. This value is used in conjunction with the starting instant defined above for determination of the low impedance transient duration.

In summary, the LRRT_C functionality verifies the following characteristics:

- Time delay of the blocking pulse with respect to the external triggering instant
- Time duration of the blocking pulse
- Impedance level during steady state conditions and during the blocking pulse

D6.3 External Interfaces

D6.3.1 Interface T1

The Interface T1 is used for exchanging commands and settings data from the LTMS to the LRRT and test results from the LRRT to the LTMS.

The LTMS commands and data to the LRRT regard:

1. Self-test and calibration of the LRRT functions.
2. Start-up or Restart after a malfunction.
3. Switching from On-line to Off-line mode and vice-versa.
4. Activate or deactivate one or more basic function (LRRT_1, LRRT_2 or LRRT_C).
5. Request for the operational status of the tool.
6. Input parameters and instrument settings for each required measurement.

The LRRT data to the LTMS regard:

1. Acknowledgement of an LTMS command.
2. Status of the tool (e.g., busy, ready, active, error codes).
3. Results from the required measurement.

The following Table 50 gives a possible list of LTMS commands for the basic functions of the LRRT.

LRRT_Mng	LRRT_1	LRRT_2	LRRT_C
General re-start	LRRT_1 Self-test	LRRT_2 Self-test	LRRT_C Self-test
LRRT_Mng status	LRRT_1 Re-start	LRRT_2 Re-start	LRRT_C Re-start
Activate LRRT_1	LRRT_1 Status	LRRT_2 Status	LRRT_C Status
Activate LRRT_2	LRRT_1 Close	LRRT_2 Close	LRRT_C Close
Activate LRRT_C	Signal power	Carrier frequency and noise	Signal C1 level
Open EXCEL file	Signal bandwidth	Signal spectrum	C1 data rate
Input from file	Centre freq. and freq. deviation	Modulation frequency	C1 jitter
Output to file	Mean data rate	Modulation depth	C1 Return Loss
Print from file	MTIE1	Pulses average width	C6 Amplitude
	MTIE2	Pulse width deviation	C6 Frequency
	Amplitude jitter	Pulse jitter	C6 Harmonics
	Delay C1/A1	Amplitude overshoot	C4 characteristics
	KER Compatibility		

Table 50: LTMS commands to LRRT

D6.3.2 Fast trigger Interface S6

This interface is used for quickly triggering the front-end instruments to start acquisition and analysis of the corresponding input signals. In such cases the time delay of the instrument to start the required operation plays an important role for the accuracy of the corresponding measurement. The instruments are pre-set to the required configuration by the corresponding LRRT functionality, prior to the estimated occurrence of the trigger event.

The S6 interface is typically a short positive pulse of 1 μ s – 10 μ s duration. It is typically generated by the RSG at pre-defined instants correlated to Balise Tele-powering or to Interface 'C' transients.

D6.3.3 Man Machine Interface – MMI

For each measurement or combination of measurements, a suitable graphical interface should allow the operator, when the tool is in local control, to send the same commands and data as those handled by the LTMS. The same MMI should allow an easy display of test results and possibly of some intermediate test data. Off-line zooming and re-scaling of the measurement results presented in graphical form should also be allowed.

The MMI should also support test data saving in files and print out of the Test Bulletins.

D6.4 Required Performance

D6.4.1 LRRT_1

- Signal power: accuracy better than 0.5 dB.
- Signal bandwidth: frequency resolution better than 10 kHz.
- Centre frequency and frequency deviation: accuracy better than 5 kHz.
- Mean data rate: accuracy better than 100 ppm.
- MTIE1 and MTIE2: accuracy better than 50 ns.
- Amplitude jitter: accuracy better than 0.2 dB.
- Interface C1/A1 delay time: accuracy better than 100 ns.
- KER compatibility: accuracy better than 1 dB.

D6.4.2 LRRT_2

- Carrier frequency: accuracy better than 50 Hz.
- Carrier noise: background noise collected by the Reference Loop less than -120 dBm.
- Carrier noise: frequency resolution better than 1 Hz.
- Carrier noise: input signal dynamics higher than 110 dB.
- Modulation frequency: accuracy better than 1 Hz.
- Toggling signal: time resolution better than 10 ns.
- Toggling signal: amplitude accuracy better than 0.02 dB.

D6.4.3 LRRT_C

- Interface C1 signal level: accuracy better than 100 mV.
- Interface C1 mean data rate: accuracy better than 10 ppm.
- Interface C1 time jitter: accuracy better than 10 ns.
- Interface C1 Return Loss: accuracy better than 0.5 dB.
- Interface C6 signal level: accuracy better than 100 mV.
- Interface C6 frequency: accuracy better than 100 ppm.
- Interface C6 harmonics power: better than 0.5 dBm.
- Interface C6 Return Loss: accuracy better than 0.5 dB.
- Interface C4: Impedance accuracy better than 10 %.
- Interface C4 Time accuracy/resolution better than 10 μ s.

Annex E (Informative), Test Interfaces for the On-board Equipment

E1 Interface V1

E1.1 General

The Interface V1 defines the data exchanged between the LTMS and the BTM functionality of the On-board ERTMS/ETCS Equipment, in order to facilitate the tests defined in Clause 5 of this specification. This Interface may require the use of a company specific Interface V1 Adapter in order to translate the required test data to formats and timings compatible with those internal to the equipment under test.

E1.2 Operational Data

E1.2.1 Mode Selection (TESTCONF)

The test configuration data, included in the variable TESTCONF, is transmitted from the LTMS to the BTM functionality via the Interface V1. It is used to set the On-board Equipment under test in a defined operational mode, among the following ones:

- Test Mode
- CW/Toggling Mode
- Down-link transmission enabled/disabled
- Tele-Powering on/off

The variable TESTCONF is a string of 7 ASCII characters organised according to the structure shown in Table 51.

Char #	Meaning	Value
Char 1	<u>Test mode:</u> on/off	“0” = off “1” = on
Char 2	<u>Separator.</u>	“-“
Char 3	<u>Tele-powering Mode:</u> CW/Toggling	“0” = CW “1” = Toggling
Char 4	<u>Separator.</u>	“-“
Char 5	<u>Down-Link:</u> on/off	“0” = off “1” = on
Char 6	<u>Separator.</u>	“-“
Char 7	<u>Tele-powering:</u> on/off	“0” = off “1” = on

Table 51: TESTCONF variable structure

The LTMS sends a new TESTCONF variable each time it requires a new operating mode for the On-board Equipment under test. The LTMS waits for a maximum time of 1 second for receiving an answer, via the BTMSTAT variable, from the Equipment under test, confirming the switch to the requested operational mode. It also waits for a maximum time of 5 second for receiving a positive answer, via the ANTTEST variable, from the same equipment confirming the correct status of the transmission units (Antenna, Transmitter, Receiver etc.).

The LTMS also checks that a coherent variable ALIVE is periodically and regularly transmitted approximately every 5 seconds from the equipment under test.

E1.2.2 Mode Status (BTMSTAT)

The status variable BTMSTAT is sent by the On-board Equipment under test to the LTMS, as a response to a new configuration request issued by the LTMS by means of a new TESTCONF variable. This response shall be issued within an overall delay time of 1 second since the mode selection order was issued.

The variable BTMSTAT is a string of 11 ASCII characters organised according to the structure shown in Table 52.

Char #	Meaning	Value
Char 1 to Char 3	<u>Header</u> : Company Acronym	“XYZ”
Char 4	<u>Separator</u> .	“-“
Char 5	<u>Test mode</u> : on/off	“0” = off “1” = on
Char 6	<u>Separator</u> .	“-“
Char 7	Tele-powering Mode: CW/Toggling	“0” = CW “1” = Toggling
Char 8	<u>Separator</u> .	“-“
Char 9	<u>Down-Link</u> : on/off	“0” = off “1” = on
Char 10	<u>Separator</u> .	“-“
Char 11	<u>Tele-powering</u> : on/off	“0” = off “1” = on

Table 52: BTMSTAT variable structure

E1.2.3 Link Status (ALIVE)

The status variable ALIVE is periodically sent by the On-board Equipment under test to the LTMS approximately every 5 seconds to confirm that the equipment and its link with the LTMS are correctly working.

The correct behaviour of the link is indicated by a modulo 10 counter that is regularly incremented by 1 at each transmission. The status of this counter is contained in the ALIVE variable sent to the LTMS.

The ALIVE variable is a string of 4 ASCII characters organised according to the structure shown in Table 53.

Char #	Meaning	Value
Char 1 to Char 3	<u>Header</u> : Company Acronym	“XYZ”
Char 4	<u>Mod. 10 counter</u> : current value	“0”, “1”, “2”, ..., “9”.’0” ...

Table 53: ALIVE variable structure

E1.3 Test Data

E1.3.1 Self-test Report (ANTTEST)

The ANTTEST variable is used to inform the LTMS about the status of the On-board transmission Equipment under test. This equipment sporadically transmits this variable to the LTMS in case of failure detection or, independently on its internal status, after a request of “Test Mode on” is received from the LTMS, via a new TESTCONF variable. In this latter case, the ANTTEST response is expected within a maximum delay time of 5 seconds.

The ANTTEST variable is a string of 5 ASCII characters organised according to the structure shown in Table 54.

Char #	Meaning	Value
Char 1 to Char 3	<u>Header</u> : Company Acronym	“XYZ”
Char 4	<u>Separator</u> .	“-“
Char 5	<u>Health Status</u> : failure/no-failure	“0” = failure “1” = no-failure

Table 54: ANTTEST variable structure

E1.3.2 Balise Passage Report (BALL_PASS)

After receiving an Up-link Balise signal, the following set of data shall be passed on by the On-board Equipment under test to the LTMS:

- Set of User Data extracted from the received telegrams (validated and decoded);
- Balise location data (given by the absolute time and/or distance from a defined reference point) referring to the Balise Reference Position either passed or preliminarily estimated;
- Overall number of non-overlapping good telegrams received between two subsequent reports to the LTMS (not the number accumulated during the Balise passage) considering the safety targets within the class of reception defined. The number of non-overlapping telegrams is defined as a number of valid bits received between two continuous reporting instants, divided by 1023 for a long telegram or by 341 for a short telegram. This resulting number is subsequently multiplied by a suitable correction factor, selected by each company under their responsibility, in order to include possible shortcomings determined by safety related verifications in the telegram acceptance.
- Percentage of number of non-overlapping good telegrams within a reporting period compared with the maximum number of non-overlapping telegrams within the same reporting period (considering the correction factor above).
- BTM function reporting time (time for data being available to the Kernel).
- Class of reception.
 - * Class A, when no error correction is implemented.
 - * Class B_n when error correction is implemented (the suffix n is any identification number defined by the supplier).

The LTMS checks the logical consistency between the various fields of the BAL_PASS variable transmitted by the BTM functionality, via the Interface V1 Adapter. Missing or erroneous reporting leads to the conclusion that the Balise Up-link signal is not correctly received.

For low speed conditions, the On-board Equipment could perform periodical reporting via the Interface V1 Adapter. The reporting period, within a Balise contact condition, could range between 50 ms and 600 ms.

The interface V1 Adapter converts the data, received from the On-board Equipment under test, to the format prescribed for the BAL_PASS variable and then transmits it to the LTMS. The LTMS should have an internal buffering capability, in order to allow the LTMS to possibly postpone the on-line data elaboration, when it has to handle more urgent tasks than the Interface V1 communication. The buffering is dimensioned so that at least 20 seconds of test data can be received without losses, even when the On-board Equipment continuously receives Balise data for a prolonged time (e.g. when the Antenna is standing still over the Balise). The buffering can be of circular type. This implies that, during a continuous flow of test data, some of the data older than 20 seconds, can sporadically be lost by the LTMS.

The BAL_PASS variable is a string of 263 ASCII characters organised according to the structure shown in Table 55. All the numbers are in decimal notation except those differently specified.

Char #	Meaning	Value
Char 1 to Char 3	<u>Header</u> : Company Acronym	“XYZ”
Char 4	<u>Separator</u> .	“-“
Char 5 to Char 212	<u>Decoded User Bits</u> : Hexadecimal notation with ASCII characters “0”, “1”, “2”, ..., “9”, “A”, ..“F”, in correspondence with the actual value of each group of 4 bits. For short telegrams, the 6 unused bits (bit211÷bit216) are set to the 0 value. For long telegrams, the 2 unused bits (bit 831 and bit 832) are set to the 0 value. For short telegrams, the unused characters are filled with the “blank” character. In case of Balise detection without valid data reception, the whole field must be filled with the ASCII character “X”.	“H ₀ ” = Hex(bit 0 to bit 3) “H ₁ ” = Hex(bit 4 to bit 7) “H ₂ ” = Hex(bit 8 to bit 11) “H ₂₀₈ ” = Hex(bit 829 to bit 832)
Char 213	<u>Separator</u> .	“-“
Char 214 to Char 224	<u>Balise Time Location</u> : TBAL gives the absolute time of the Balise centre passage. TBAL is a string of 11 ASCII characters identifying hours, minutes, seconds, milliseconds and tenths of milliseconds. If this variable is not used, the corresponding fields must be filled with ASCII “space” characters.	“HH” – hours “MM” – minutes “SS” – seconds “.” – decimal point “mmm” – milliseconds “μ” – hundreds of microsecond
Char 225	<u>Separator</u> .	“-“
Char 226 to Char 235	<u>Balise Distance Location</u> : MBAL gives the absolute distance of the Balise centre passage, from a reference position. MBAL is a string of 10 characters identifying the distance in millimetres. If this variable is not used, the corresponding fields must be filled with the ASCII “space” characters.	“mmmmmmmmmm” – millimetres
Char 236	<u>Separator</u> .	“-“
Char 237 to Char 247	<u>BTM Reporting Time</u> : TBTM gives the absolute time of when the BALL_PASS variable is made available for external reporting. TBTM is a string of 11 ASCII characters identifying hours, minutes, seconds, milliseconds and tenths of milliseconds.	“HH” – hours “MM” – minutes “SS” – seconds “.” – decimal point “mmm” – milliseconds “μ” – hundreds of microsecond
Char 248	<u>Separator</u> .	“-“

Char #	Meaning	Value
Char 249 to Char 254	<u>Overall number of non-overlapping good telegrams:</u> TEL is a string of 6 ASCII characters giving the decimal number of received telegrams. Alternatively, the variable "Percentage of good telegrams" may be reported. If this variable is not used, the corresponding fields shall be filled with ASCII "space" characters.	"M" – thousands "H" – hundreds "D" – tens "U" – units "." – decimal point "T" – tenth
Char 255	<u>Separator.</u>	"_"
Char 256 to Char 257	<u>Class of Reception:</u> RXCL is a string of 2 ASCII characters giving the implemented Class of reception.	"A" - No error correction "B1" – Error correction of type 1 "B2" – Error correction of type 2 "Bn" – Error correction of type n
Char 258	<u>Separator</u>	"_"
Char 259 to Char 263	<u>Percentage of good telegrams:</u> PTEL is a string of 5 ASCII characters giving the decimal number of percentage of good received telegrams. Alternatively, the variable "Overall number of non-overlapping good telegrams" may be reported. If this variable is not used, the corresponding fields shall be filled with ASCII "space" characters.	"H" – hundreds "D" – tens "U" – units "." – decimal point "T" – tenth

Table 55: BAL_PASS variable structure

E2 Interface V2

E2.1 General

The Interface V2 defines the data exchanged between the LTOM and the On-board Transmission Equipment under test, in order to facilitate the tests defined in Clause 5 of this specification. This Interface may require the use of a company specific Interface V2 Adapter in order to translate the required test data to formats and timings compatible with those internal to the equipment under test.

This interface is mostly used when the antenna/BTM functionality is tested as stand-alone equipment. The values given by the LTOM must represent realistic cases for the entire duration of the test session. This requires that the Interface is fed, as far as possible, regularly and without interruptions and that the transmitted values are self-consistent and do not present any lack of continuity for all possible operational modes.

E2.2 Interface V2 Data

The following data is periodically transmitted by the LTOM:

- Current distance of the On-board Antenna centre from the starting point of the test session or from the last “reset” point.
- Current time since the start of the test session or since the last “reset” instant.
- Confidence level of the current time and odometric co-ordinates (for any manufacturer specific use).
- Current speed (real or simulated) of the on-board Antenna.
- Data allowing the check of regularity and integrity of the transmitted data (Sequence Number and CRC code).

The data is transmitted every 50 ms in a serial way according to the telegram structure reported in Table 56.

The whole telegram transmission must be sufficiently short (i.e., less than 2 ms) in relation to the worst-case train acceleration or deceleration, in order to minimise time delay errors.

The periodicity of the transmission must be sufficiently stable (i.e., uncertainty less than 5 µs), both in the short and in the long term, so as to allow time or distance evaluations, based on the transmitted data, of long test runs with good accuracy levels (e.g., better than 0.1 ms for time based events and 10 mm for distance based ones).

The Sequence Number consists of a modulo 255 counter variable, incremented by 1 at each telegram transmission. It is used by the On-board Equipment (or Interface V2 Adapter) to check the correct operation of the LTOM functionality and the regularity of the Interface V2 link.

The integrity of the whole set of transmitted data is allowed by a CRC protection code characterised by the following generator polynomial:

$$X^{32} + X^{30} + X^{27} + X^{25} + X^{22} + X^{20} + X^{13} + X^{12} + X^{11} + X^{10} + X^8 + X^7 + X^6 + X^5 + X^4 + X^0$$

No handshaking procedure is foreseen between the LTOM and the equipment under test, for managing possible transmission error occurrences.

#	Variable	Format	Resolution	Comment
1	Distance	Unsigned integer 4 bytes	1 cm	Absolute current position of the antenna (since the last re-start)
2	Distance Error	Unsigned integer 4 bytes	1 cm	Intended for company specific use
3	Speed	Signed integer 2 bytes	0.01 m/s	Speed and direction of the antenna motion
4	Time	Unsigned integer 4 bytes	0.1 ms	Absolute current time (since the last re-start) referred to the start of the telegram transmission
5	Time Error	Unsigned integer 1 byte	0.1 ms	Intended for company specific use
6	Sequence Number	Unsigned integer 1 byte	-	Intended for Transmission regularity checks
7	CRC	4 bytes	-	Intended for data integrity checks

Table 56: Telegram format for the Interface V2

E3 Interface V4

E3.1 General

The Interface V4 defines the information associated to the signals generated by the LTOM for feeding the On-board Transmission Equipment under test, in order to facilitate the tests defined in Clause 5 of this specification. This Interface may require the use of a company specific Interface V4 Adapter in order to translate the required test signals to levels and shapes compatible with those required by the equipment under test.

This interface is mostly used when the antenna/BTM functionality is tested as an integrated functionality of the overall ERTMS/ETCS On-board Equipment. The Interface V4 signals must represent realistic cases for the entire duration of the test session. This requires that the Interface is fed, as far as possible, regularly and without interruptions and that the signals are always self-consistent and do not present any lack of continuity for all possible operational modes.

E3.2 Interface V4 Signals

A pair of synchronised square-wave signals, whose period corresponds to a pre-defined longitudinal distance run by the On-board antenna and whose phase difference corresponds to the running direction, constitute the Interface V4.

The LTOM generates these real-time speed signals, coherent with the longitudinal speed (real or simulated) used in the tests, for feeding the On-board equipment in a similar way as with the speed sensors used in real operation.

The LTOM can be configured in such a way that the period of the square waves corresponds to a pre-defined distance, ranging between 1 mm and 50 mm, with resolution of 1 mm.

The phase difference between the two signals is typically 90 degrees for a positive speed and -90 degrees for a negative speed.

In order to allow the best accuracy during fast acceleration/deceleration transients, the signal frequency updating shall be performed by the LTOM at each waveform transient (i.e. 4 times per period).

E4 Physical and Link Control

E4.1 Architecture

The following general architecture applies for connecting the On-board system under test to the test environment via Interface 'V'.

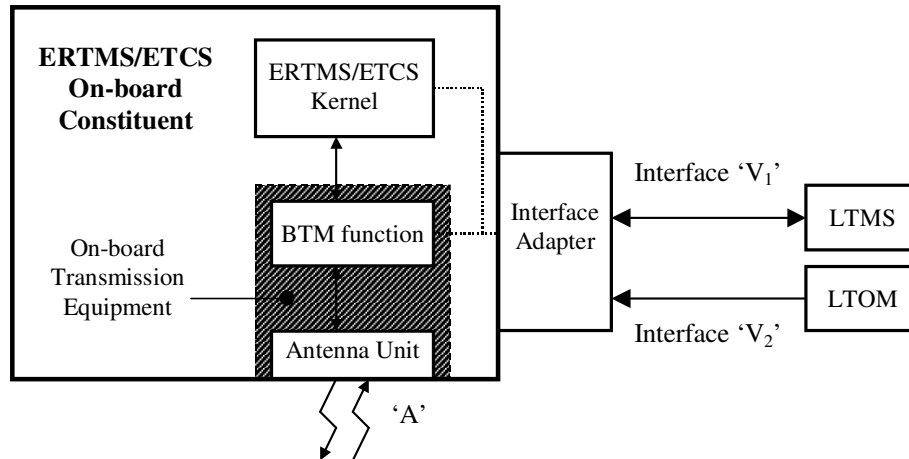

Figure 70: Architecture

The data to be exchanged between the On-board system and the test environment (in this case the LTMS and LTOM respectively) is defined in Clause E1 on page 275 and Clause E2 on page 280.

In general, interaction via Interface 'V₁' is defined through the following variables:

- Mode Selection
- Mode Status
- Link Status
- Self Test Report
- Balise Passage Report

The variables are of various lengths, and no checksum mechanism is defined on that level. The variables are transmitted on a one by one basis at various repetition rates or instants.

Interaction via Interface 'V₂' is defined through the following variables:

- Distance
- Distance Error
- Speed
- Time
- Time Error
- Sequence Number

Also in this case, the variables are of various lengths, but a 32-bit CRC is defined (together with a defined generator polynomial). All these variable are transmitted as one complete package each 50 ms.

Further details are found in Clause E1 on page 275 and Clause E2 on page 280.

E4.2 Physical Control

E4.2.1 General

Interface 'V₁' and Interface 'V₂' shall use two physically separated transmission channels.

The channel for Interface 'V₁' shall constitute full duplex communication, and the channel for Interface 'V₂' shall constitute simplex communication. No handshaking shall be used.

The media for Interface 'V₁' shall be two twisted shielded pairs of wires, and the media for Interface 'V₂' shall use one twisted shielded pair of wires. The nominal characteristic impedance of the cable shall be 120 Ω.

The interfaces shall fulfil the requirements of the RS485 standard.

The connector layout and the disposition of the connector in the interface adapter are company specific.

E4.2.2 Interface 'V₁', Mechanical Data

DSUB connectors with 9 pins/sockets shall be used.

Connector layout:

Interface Adapter side ³⁰		LTMS side	
Pin	Signal	Pin	Signal
	Positive Adapter Transmit terminal	1	Ground
	Negative Adapter Transmit terminal	2	Ground
	Ground	3	Unconnected
	Positive LTMS Transmit terminal	4	Positive Adapter Transmit terminal
	Negative LTMS Transmit terminal	5	Negative Adapter Transmit terminal
		6	Unconnected
		7	Unconnected
		8	Positive LTMS Transmit terminal
		9	Negative LTMS Transmit terminal

Table 57: Pin Configuration for Interface 'V₁'

The cable connector in the LTMS end of the cable shall be of female type.

The cable connector in the Interface Adapter end of the cable shall be of male type.

Note: Adequate termination shall be performed in the LTMS (a load resistor shall be connected between pins 4 and 5 of the LTMS cable connector).

³⁰ The actual configuration with respect to pinning and disposition of the connector in the Interface Adapter are company specific.

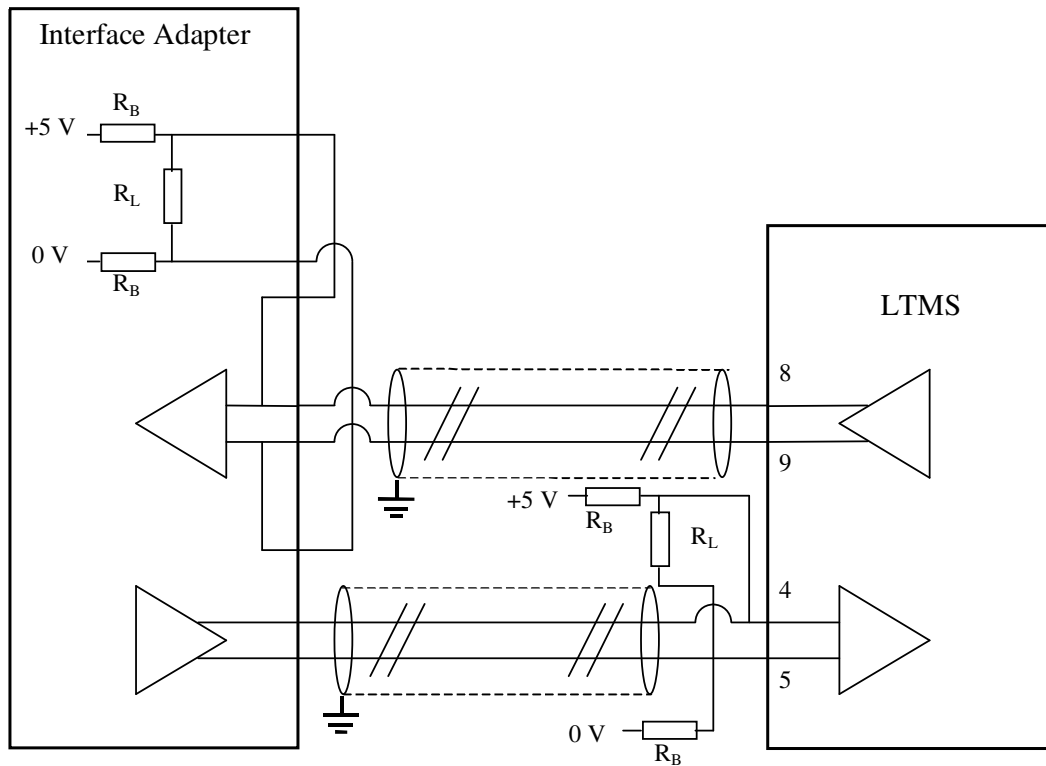

Figure 71: Physical Configuration for Interface 'V₁'

The load resistance R_L shall be $110 \Omega \pm 10 \Omega$.

The biasing resistors R_B shall be $650 \Omega \pm 30 \Omega$.

Please observe that the actual configuration with respect to pinning and disposition of the connector in the Interface Adapter are company specific. The load and biasing resistors indicated inside the Interface Adapter may also be external to the Interface Adapter (similarly to the LTMS side).

E4.2.3 Interface ‘V₂’, Mechanical Data

DSUB connectors with 9 pins/sockets shall be used.

Connector layout:

Interface Adapter side ³¹		LTOM side	
Pin	Signal	Pin	Signal
		1	Ground
		2	Ground
	Ground	3	Unconnected
	Positive LTOM Transmit terminal	4	Unconnected
	Negative LTOM Transmit terminal	5	Unconnected
		6	Unconnected
		7	Unconnected
		8	Positive LTOM Transmit terminal
		9	Negative LTOM Transmit terminal

Table 58: Pin Configuration for Interface ‘V₂’

The cable connector in the LTOM end of the cable shall be of female type.

The cable connector in the Interface Adapter end of the cable shall be of male type.

Note: Adequate termination shall be performed in the Interface Adapter.

³¹ The actual configuration with respect to pinning and disposition of the connector in the Interface Adapter are company specific.

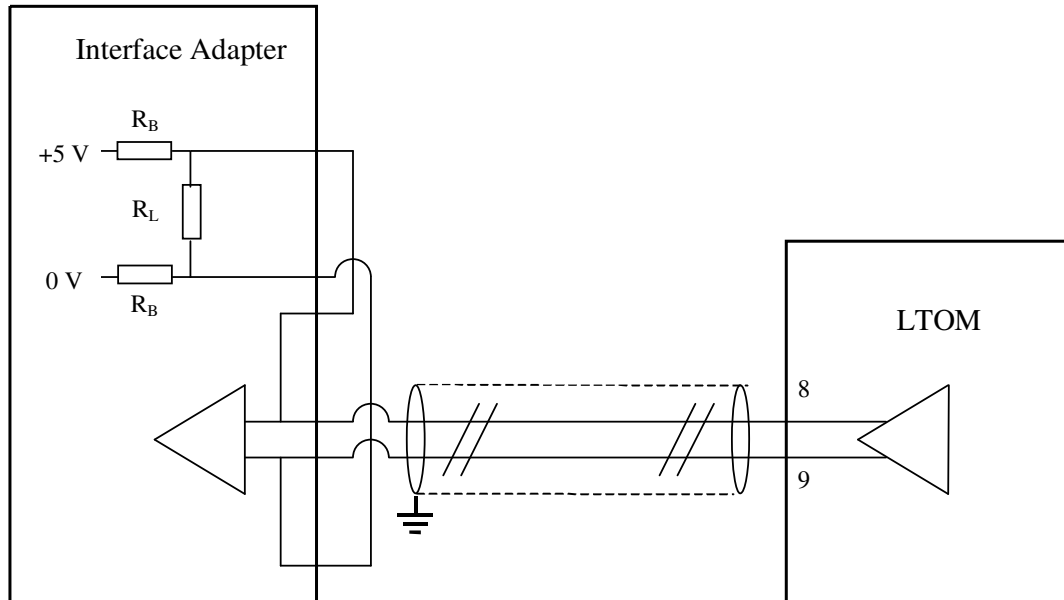

Figure 72: Physical Configuration for Interface 'V₂'

The load resistance R_L shall be 110 Ω ±10 Ω.

The biasing resistors R_B shall be 650 Ω ±30 Ω.

Please observe that the actual configuration with respect to pinning and disposition of the Interface Adapter are company specific. The load and biasing resistors indicated inside the Interface Adapter may also be external to the Interface Adapter.

E4.3 Link Control

E4.3.1 General

The used communication channels shall be RS485. The applicable port configuration shall be:

- Data Rate 115.2 kbit/s
- Idle state of the channels at the high level (logical ‘one’)
- No Parity
- One start bit (a ‘zero’)
- 8 data bits (direct NRZ encoding)
- One stop bit (a ‘one’)

E4.3.2 Interface ‘V₁’

The variables defined in Clause E1 on page 275 shall be transmitted on a one by one basis. Each variable shall be preceded by a unique header, a sequence number, and information on length of data, and shall be succeeded by a 32-bit CRC. This is illustrated as follows.

Header (1 byte)	Seq. Number (1 byte)	Length of Data (2 bytes)	Variable (X bytes)	CRC (4 bytes)
--------------------	-------------------------	-----------------------------	-----------------------	------------------

The header before the package of variables (and before the ‘Length of Data’ and ‘Seq. Number’ fields) shall be one byte long and consist of a unique value for each variable as defined below.

The ‘Length of Data’ field shall be two bytes long and include the number of data bytes in the ‘Variable’ field (which in this case is as recalled below). The most significant byte shall be transmitted first.

The ‘Seq. Number’ field shall be one byte long and include a counter (individual for each variable) that is incremented by one each time the variable is transmitted. The variable shall be a modulo 256 counter (counting 0 to 255), which is initialised to zero at power on or if the interface adapter is reset.

The ‘Variable’ of the succeeding field has the following length, and shall be announced by the below defined header:

- | | | |
|------------------------------------|------------|--------------------------------|
| • Mode Selection (TESTCONF) | Header = 0 | Length of Data = 7 (decimal) |
| • Mode Status (BTMSTAT) | Header = 1 | Length of Data = 11 (decimal) |
| • Link Status (ALIVE) | Header = 2 | Length of Data = 4 (decimal) |
| • Self Test Report (ANTTEST) | Header = 3 | Length of Data = 5 (decimal) |
| • Balise Passage Report (BAL_PASS) | Header = 4 | Length of Data = 263 (decimal) |

In the event that the interface adapter detects unacceptably frequent corruption of Interface 'V₂' data, it should inform the LTMS. This should be performed through the sporadic transmission of a Self-test Report (variable ANTTEST) via Interface 'V₁'. In this case the ANTTEST variable should be assigned the value "2" (with the meaning "Adapter Failure"). After this, the LTMS shall terminate the test that is in progress, and re-start the test.

E4.4 Interface 'V₁' Link Synchronisation

E4.4.1 General

There are four different scenarios where the synchronisation mechanism applies:

- During an initial switching ON sequence. There are two possibilities:
 - Case 1 – The BTM is switched on before the Interface 'V₁' driver
 - Case 2 – The Interface 'V₁' driver is switched on before the BTM
- During re-starting scenarios. There are two possibilities:
 - Case 3 – The Interface 'V₁' driver is re-started but the BTM remains on
 - Case 4 – The BTM is re-started but the Interface 'V₁' driver remains on

The general mechanism used by the Interface 'V₁' driver to synchronise with the BTM is that for each BTMSTAT, ALIVE, ANTTEST, or BALPASS variable, whose internal sequence number (i.e., the sequence number stored by the Interface 'V₁' driver that is received from the BTM) is equal to 0, the Interface 'V₁' driver updates itself with the sequence number (SN) received from the BTM. See also sub-clause E4.4.6 on page 295.

In general, when stating "BTM" in this sub-clause, it implies "BTM and/or company specific Interface 'V' adapter".

E4.4.2 Case 1 – The BTM is switched on before the Interface 'V₁' driver

Case 1 is the normal situation. As shown in Figure 73, the Interface 'V₁' driver internally synchronises with the ALIVE variable, thus modifying its sequence number.

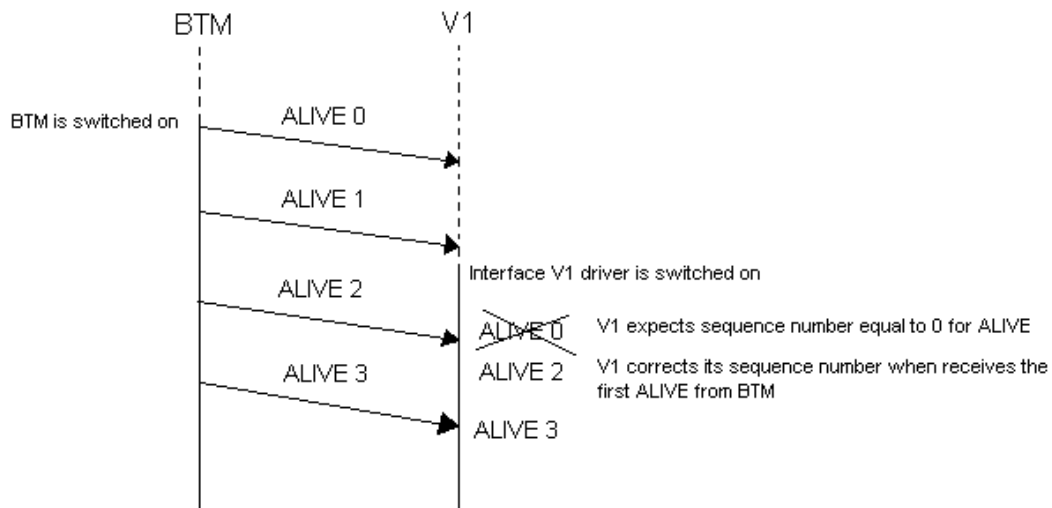

Figure 73: Case 1

E4.4.3 Case 2 – The Interface ‘V₁’ driver is switched on before the BTM

Case 2 is not a normal case because the BTM is normally switched on before the Interface ‘V₁’ driver. However, it might happen, and then the BTM shall be able to synchronise with the Interface ‘V₁’ driver. As shown in Figure 74, the Interface ‘V₁’ driver waits for some time to receive the ALIVE status from the BTM. It gives a time out error after some time as no ALIVE variable has been received.

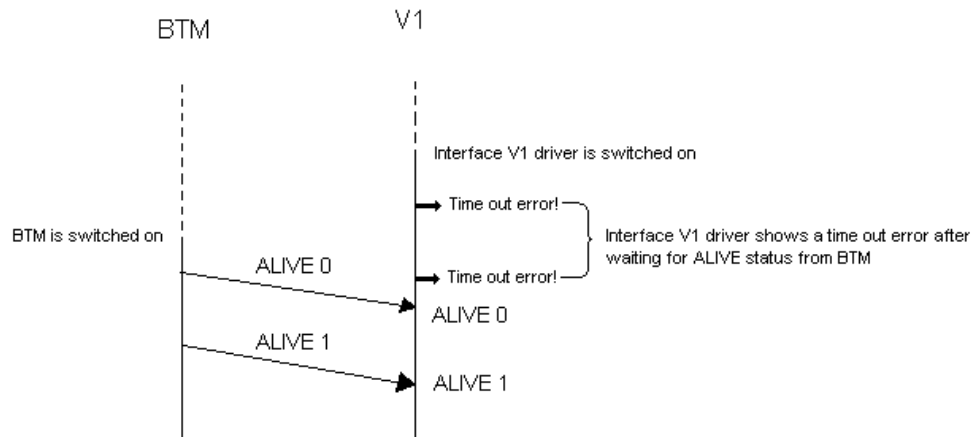

Figure 74: Case 2

E4.4.4 Case 3 – The Interface ‘V₁’ driver is re-started but the BTM remains on

This case could happen sometimes. If a test procedure has finished and a new one is started, the BTM remains on whereas the Interface ‘V₁’ driver is closed in the first test procedure and re-opened again in the second one. The Interface ‘V₁’ driver needs to synchronise with the BTM.

As shown in Figure 75, the Interface ‘V₁’ driver is re-started at some point of time. The first time the Interface ‘V₁’ driver receives a variable from the BTM, the Interface ‘V₁’ driver internally synchronises with the variable in a similar way as in Case 1. This normally happens with ALIVE, BTMSTAT, ANTTEST (when transmitted sporadically), and BALPASS variables.

When the Interface ‘V₁’ driver sends a TESTCONF variable after being re-started, the BTM is the one that synchronises with the Interface ‘V₁’ driver as shown in Figure 76. The BTM does not answer with a BTMSTAT variable the first time. This is due to synchronisation mechanism. The BTM needs a second TESTCONF variable to continue the communication.

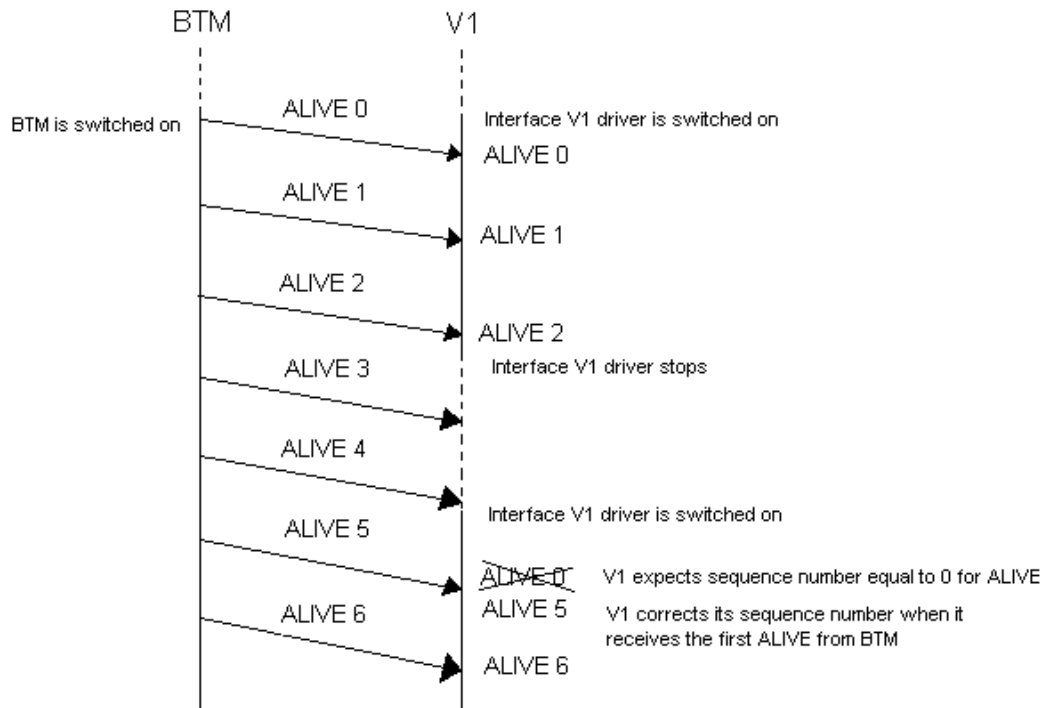

Figure 75: Case 3, ALIVE variable

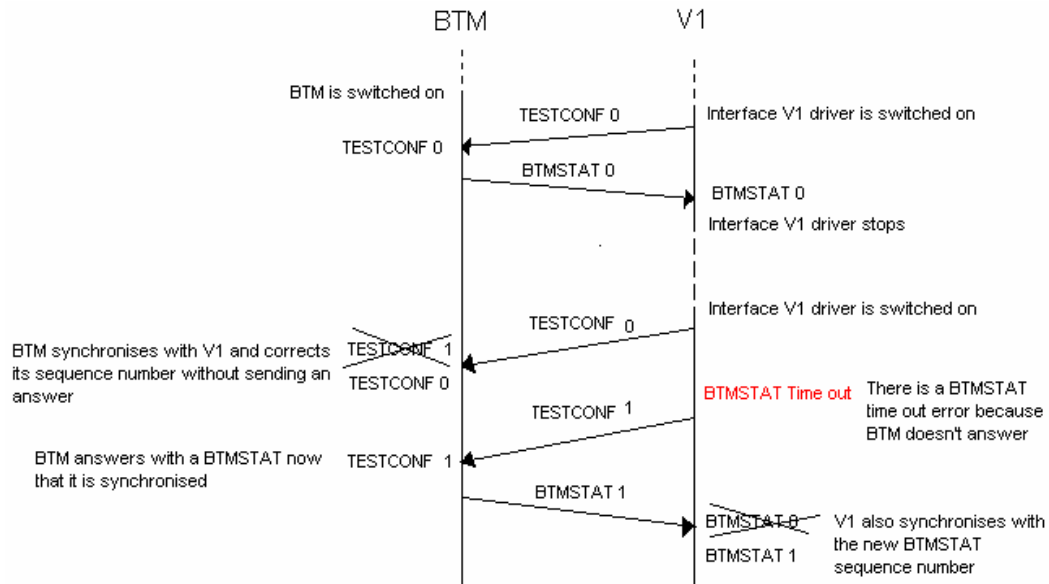

Figure 76: Case 3, TESTCONF variable

It should be considered that the BTM behaviour depends on each single implementation. This description only intends to clarify the behaviour of the Interface ‘V₁’ driver.

In this case (Case 3), there might be various BTMs that answer with BTMSTAT and/or ANTEST to the first TESTCONF. This is also a correct implementation as long as the sequence number is correctly updated.

Refer to the description of the synchronisation mechanism in sub-clause E4.4.6 on page 295 to understand all the possible situations.

E4.4.5 Case 4 – The BTM is re-started but the Interface ‘V₁’ driver remains on

This case is an abnormal situation from the test procedure point of view. If the Interface ‘V₁’ driver is active, this is because the test procedure is under execution. While the test procedure is running the BTM cannot be restarted. If the BTM is restarted during a test procedure, this is due to a BTM failure. In that case, the test procedure should stop and re-start again with a correctly operating BTM.

The BTM, and the Interface ‘V₁’ driver, are re-started and synchronise according to Case 1.

E4.4.6 Behaviour of the Interface 'V₁' driver

The following behaviour is implemented in the Interface 'V₁' driver.

1. The Interface 'V₁' driver sends a TESTCONF variable and waits for the corresponding BTMSTAT variable from BTM.

If BTMSTAT is received, the Interface 'V₁' driver:

- Displays the received status in the button indicators.
- The first time (Interface 'V₁' SN = 0), it does not check the SN of BTMSTAT answer, but it updates its own SN with the new one coming from the BTM. No error is displayed. In all the subsequent cases it checks the incoming SN and, if different from its own, it displays "Stat Sequence Number" error.
- If BTMSTAT has a status different from the requested TESTCONF status, there is an error message "BTMSTAT error", and the button indicators appear grayed.
- If BTMSTAT is received outside the Time out, it displays "Stat Time out" error.

If BTMSTAT is not received, the Interface 'V₁' driver:

- Displays the error "Stat Time out".
- Displays the error "BTMSTAT error".

2. In particular, when the Interface 'V₁' driver sends a TESTCONF variable with test mode ON, it waits also for the corresponding ANTTEST variable from the BTM.

If ANTTEST is received, the Interface 'V₁' driver:

- Displays the three characters of the company acronym plus the received value of "Health Status" in the ANTTEST display.
- The first time (Interface 'V₁' SN = 0), it does not check the SN of "Health Status" answer, but it updates its own status with the new one coming from the BTM. No error is displayed. In all the subsequent cases, it checks the incoming SN and, if different from its own, it displays "Ant Test Sequence Number" error.
- If "Health Status" is not equal to 1, "Ant Test health" error is displayed.
- If ANTTEST is received outside the Time out (only with the Test Mode ON), it displays the error "Ant Test Time out".

If ANTTEST is not received, the Interface 'V₁' driver:

- Displays the error "Ant Test Time out".

3. The Interface 'V₁' driver checks continuously if ANTTEST is received from the BTM. In case of sporadic reception, it:

- Displays the three characters of the company acronym plus the received value of "Health Status" in the ANTTEST display.
- The first time (Interface 'V₁' SN = 0), it does not check the SN of the "Health Status" answer, but it updates its own status with the new one coming from the BTM. No error is displayed. In all the subsequent cases, it checks the incoming SN and, if different from its own, it displays "Ant Test Sequence Number" error.
- If "Health Status" is not equal to 1, "Ant Test health" error is displayed.

4. The Interface 'V₁' driver waits continuously for BTM alive status.

When ALIVE is received by the Interface 'V₁' driver, it:

- Displays the three characters of the company acronym plus the "Mod 10 counter" in the ALIVE display.
- The first time (Interface 'V₁' SN = 0) it does not check the SN of "Alive", but it updates its own status with the new one coming from the BTM. No error is displayed. In all the subsequent cases, it checks the incoming SN and, if different from its own, it displays "Alive Sequence Number" error.
- The first time (Interface 'V₁' SN = 0) it does not check the "Mod 10 counter" of Alive, but it updates its own status with the new one coming from the BTM. No error is displayed. In all the subsequent cases, it checks the incoming "Mod 10 counter" of "Alive" and, if different from its own, it displays "Alive Modulo 10" error.
- The first time (Interface 'V₁' SN = 0) it does not check if it is received within Alive period + tolerance. No error is displayed. In all the subsequent cases, it checks if it is received within the Alive period + tolerance.

If ALIVE is not received or is received outside the Alive period \pm tolerance, "Alive period" error is displayed.

5. The Interface 'V₁' driver checks continuously if BALPASS is received from the BTM. When BALPASS is received, the Interface 'V₁' driver:

- Displays the received variable in the BALPASS table.
- The first time (Interface 'V₁' SN = 0) it does not check the SN of BALPASS, but it updates its own status with the new one coming from the BTM. No error is displayed. In all the subsequent cases, it checks the incoming SN and, if different from its own, displays "BalPass Sequence Number" error.

Annex F (Informative), Test Tools and Instruments

F1 Recommended Test Tools and Instruments

The following list includes suitable test equipment. Other equipment with similar performance may substitute these. "Item" refers to numbers in the Test and Calibration configurations.

<u>Item:</u>	<u>Equipment:</u>	<u>Type:</u>	<u>Comment:</u>
1	Signal Generator	HP 8647A	
2	Attenuator	6 dB	
3	RF Power Amplifier	Amplifier Research 150A100B	150 W
4	Attenuator	3 dB	100 W
5	(Standard) Test Antenna	see clause H3 on page 316	
6	Modified Test Antenna	see clause H3 on page 316	
7	Reference Loop	various, see sub-clause H2.1 on page 309	
8	Reference Loop Balun	see clause H5 on page 327	
9	Attenuator	20 dB	
10	Power Meter Power Sensors	R&S NRVD R&S NRV-Z5	
11	Attenuator	10 dB	
12	Low Pass Filter	Mini Circuits, BLP-10.7	See also clause F3 on page 302.
13	Reference Signal Generator	see clause D2 on page 222	
14	Current Sense Balun	see clause H5 on page 327	Has to be calibrated
15	Vector Signal Analyser	HP 89410A	Set for 1.2 MHz bandwidth. Has to be calibrated against a power me- ter.
16	Pre-amplifier	Mini Circuits, 15542 ZFL-500	
17	4.2 MHz Antenna	see clause H4 on page 322	
18	Activation Antenna	see clause H4 on page 322	

<u>Item:</u>	<u>Equipment:</u>	<u>Type:</u>	<u>Comment:</u>
19	Reduced Size Reference Loop	see sub-clause H2.1 on page 309	
20	General purpose Balun	see clause H5 on page 327	
21	Deleted		
22	Network Analyser	HP 3577A	Including S-parameter test set HP 35677A.
23	Directional Coupler	DDC-2112 R5-40	RF Power Inc.
24	Deleted		
25	Deleted		
26	Deleted		
27	Adjustable Attenuator	AC401/AC501	Pascall
28	RF Power Amplifier	ENI 325LA	30 W
29	Attenuator	3 dB	30 W
30	Deleted		
31	Attenuator	20 dB	20 W, VSWR < 1:1.05
32	Current probe	Tektronix CT-2	Has to be calibrated
33	Attenuator	10 dB	20 W, VSWR < 1:1.05
34	Interface V ₁ adapter		Supplier specific
35	Spectrum Analyser	HP 8594E	
36	RF Switch	CX-600N	Toyo Tsusho
37	Oscilloscope	TDS 754A	Tektronix
38	Laboratory Test Management System	see clause D5 on page 247	
39	Laboratory Time and Odometer Module	see clause D1 on page 215	
40	Interface V ₂ Adapter		Company specific
41	Vector Signal Analyser	HP 89441A	
42	Laboratory Reference Receiver	see clause D6 on page 260	
43	Network Analyser	HP 8751A	Including S-parameter test set HP 87511A.
44	LZB Loop	See Annex J	
45	High Power Low Pass Filter	See clause F2 on page 299	
46	Adjustable Attenuator		Step size ≤0.5 dB

F2 Recommended High Power Low Pass Filter

F2.1 Characteristics

The following characteristics apply:

- Capability of handling a continuous power higher than 50 W at 27 MHz, and a pulsed power higher than 100 W at 4 MHz for about 100 ms each second.
- Input and output Voltage Standing Wave Ratio better than 1.4:1, within the band 3 MHz to 6 MHz.
- Input and output Voltage Standing Wave Ratio better than 1.2:1, within the band 3.8 MHz to 4.6 MHz.
- Attenuation, within the band 3 MHz to 6 MHz, less than 0.3 dB.
- Attenuation ripple within the band 3 MHz to 6 MHz, less than 0.1 dB.
- Group delay variation within the band 3 MHz to 6 MHz, less than ± 10 ns.
- Attenuation above 27 MHz higher than 60 dB.

F2.2 Suggested Implementation

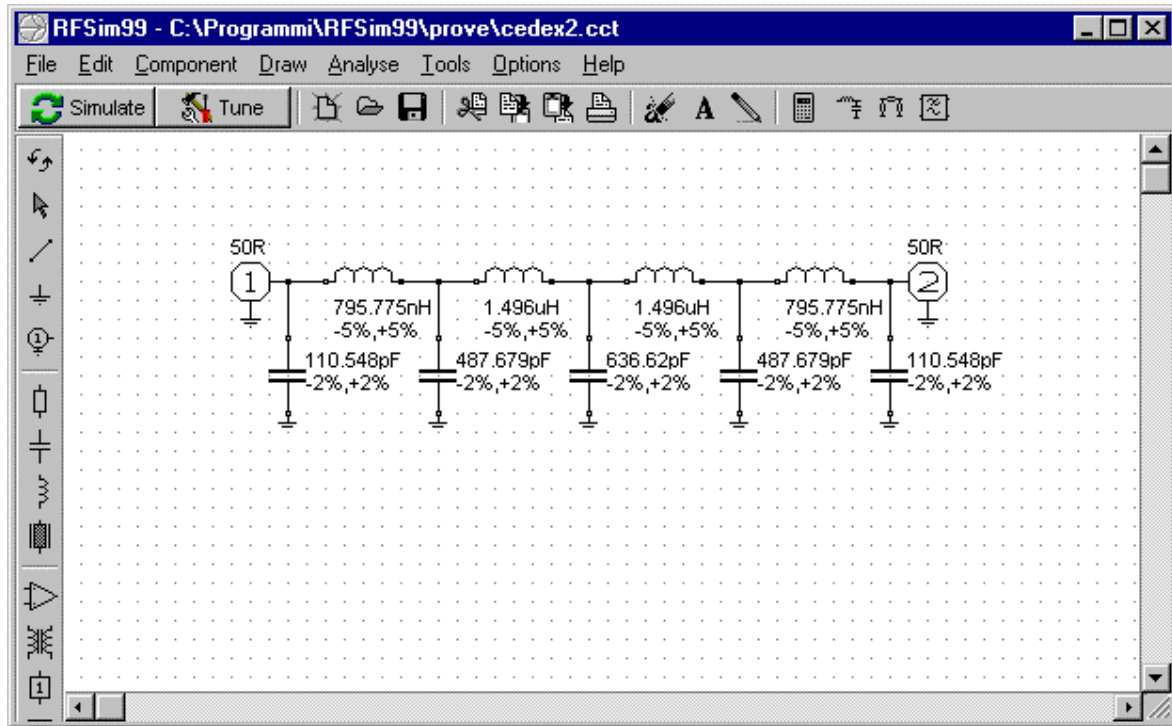

Figure 77: High Power Low Pass Filter

In general, the recommended characteristics for the included components are:

- Each capacitance shall be implemented using at least two ceramic NP0 capacitors in parallel. The voltage rate shall be at least 100 V, and the Q-value shall be better than or equal to 100.
- Each inductance is a custom made inductor wound on a toroid ferrite core. The recommended core device is type T-50-6 supplied by Amidon Corporation ($A_C = 0.121 \text{ cm}^2$, $V_C = 0.367 \text{ cm}^3$, $A_L = 46 \text{ } \mu\text{H}/100 \text{ turns}$). The wire area shall be at least 0.6 mm^2 .

F2.3 Inductor characteristics

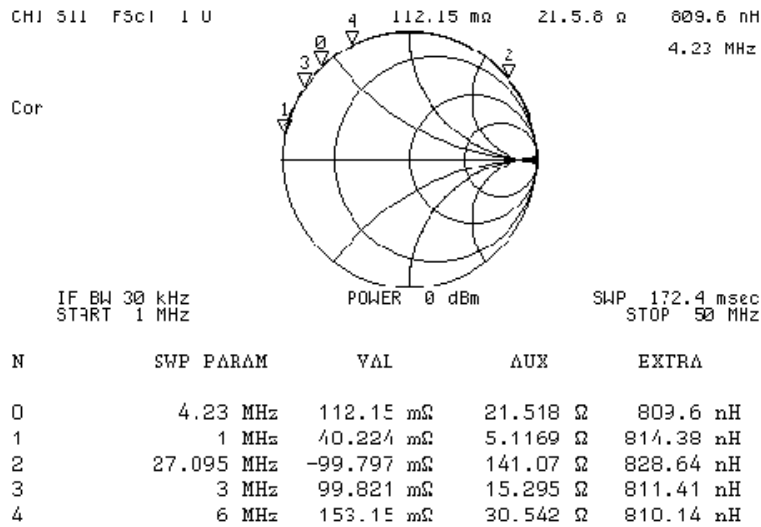

Figure 78: Frequency characteristics of the 0.8 μH Inductor (measurement)

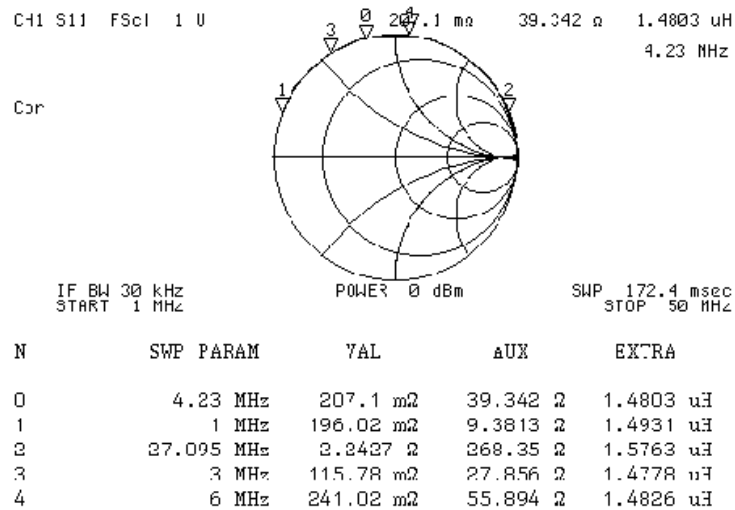

Figure 79: Frequency characteristics of the 1.5 μH Inductor (measurement)

F3 Specific Low Pass Filter Characteristics

The following specific characteristics apply to the low pass filter (Mini Circuits, BLP-10.7):

- Input and output Voltage Standing Wave Ratio better than 1.2:1, within the band 1 MHz to 6 MHz. ³²
- Group delay variation within the band 3 MHz to 6 MHz, lower than ± 10 ns.

Apart from the above, the general recommended characteristics for item 12 in clause F1 on page 297 apply.

The applicable temperature range where characteristics shall be fulfilled is from 0 °C to 40 °C.

³² The Mini Circuit data sheet guarantees a VSWR better than 1.7:1 over the entire temperature and frequency ranges. Measurements of several items confirm a value better than 1.2:1 over the applicable limited temperature and frequency ranges.

Annex G (Informative), Recommended Test Procedures

G1 Testing of LEU output Return Loss

G1.1 Test Abstract

The Return Loss properties of the LEU are checked in accordance with the requirements given in UNISIG SUBSET-036 in order to ensure correct interaction with the Balise.

The measurement of the Interface 'C1' Return Loss of the LEU is carried out, during its normal operation, by the use of a Network Analyser injecting suitable test signals and measuring the corresponding reflected power. The measurements shall be preceded by a suitable calibration procedure as defined herein. Thereafter, the Return Loss shall be directly measured.

In the case of Interface 'C6', the approach has to be modified since the S-parameter test sets that are available do not cover its very low operating frequency (8.8 kHz).

Tailoring of these test methods is allowed if it can be shown that the same results are obtained, and if the same properties are explored

G1.2 Test Set-up for Interface 'C1'

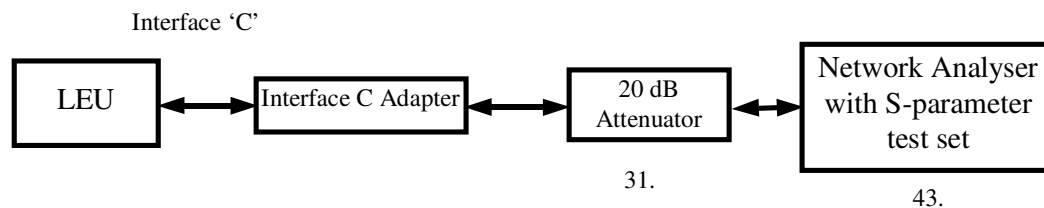

Figure 80: Test set-up for testing Interface 'C1' Return Loss

The Network Analyser can be any set of commercial instrument ensuring the operation defined in the next sub-clause. In particular the used Port of the Network Analyser shall be able to handle signal levels higher than or equal to 10 dBm. Suggested suitable equipment is found in clause F1 on page 297.

The 20 dB Attenuator can be any commercial RF device capable of handling an input power higher than 2 W. It is connected to the Port 1 terminal of the S Parameter Test Set.

The Interface 'C' Adapter shall fulfil the following functions:

- Adaptation of the non standardised mechanical and electrical properties of the LEU Interface 'C' to the characteristics of the 20 dB Attenuator;
- Adaptation of the input impedance of the 20 dB Attenuator (typically 50 Ω) to the 120 Ω loading impedance of the LEU, as required for the test.

The following Figure 81 suggests a possible solution for the Interface 'C' Adapter.

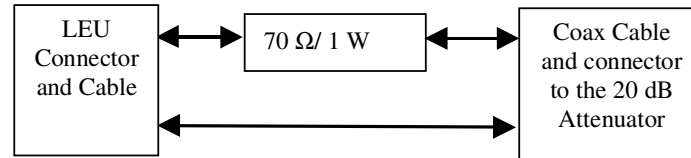

Figure 81: Interface C Adapter

The link between the LEU output and the Network analyser (all included) shall not be longer that three meters. The 70 Ω resistor may be split into two separate resistors connected to the two polarities of the LEU output.

G1.3 Calibration of the test set-up for Interface 'C1'

The S11 “full one port calibration” of the network analyser shall be performed by connecting “open”, “short”, and “120 Ω reference” to the point where the LEU output port is to be connected (i.e., the 20 dB Attenuator and the Interface 'C' Adapter shall be included in the calibration).

The following settings shall be used for both the calibration and the subsequent measurements:

Power Level:	+15 dBm
Internal attenuators:	30 dB
Resolution bandwidth:	2 Hz
Measurement:	S11 refl.
Display Format:	LogMAG (i.e. $20 \cdot \log(S11)$)
Vertical scale:	2 dB/div
Sweep:	200 kHz to 600 kHz
Number of test points:	>50 (evenly spaced)
Averaging factor:	>5

After completion of the calibration, record the calibration status into a suitable media for possible uses later on.

G1.4 Test Procedure for Interface 'C1'

Connect the LEU to the calibrated network analyser, set in the same state as after the previous calibration, and switch it on. Perform the test using a long telegram (i.e., the telegram N. 18 of Table 23 on page 162).

1. Command the LEU to transmit the current telegram.
2. Restart the averaging process and wait for the completion of the new test step.
3. Record the final diagram generated by the Network Analyser (see example in Figure 82) on a suitable medium.
4. The Network Analyser directly provides the related absolute value of the Reflection Coefficient (in dB) within the required frequency range. Check that, in all its points, the diagram is below the allowed value of Return Loss (with inverted sign). Exclude from this check possible unrealistic values coming from interference with harmonics of the LEU signal (e.g., in small regions around 282 kHz and 565 kHz).

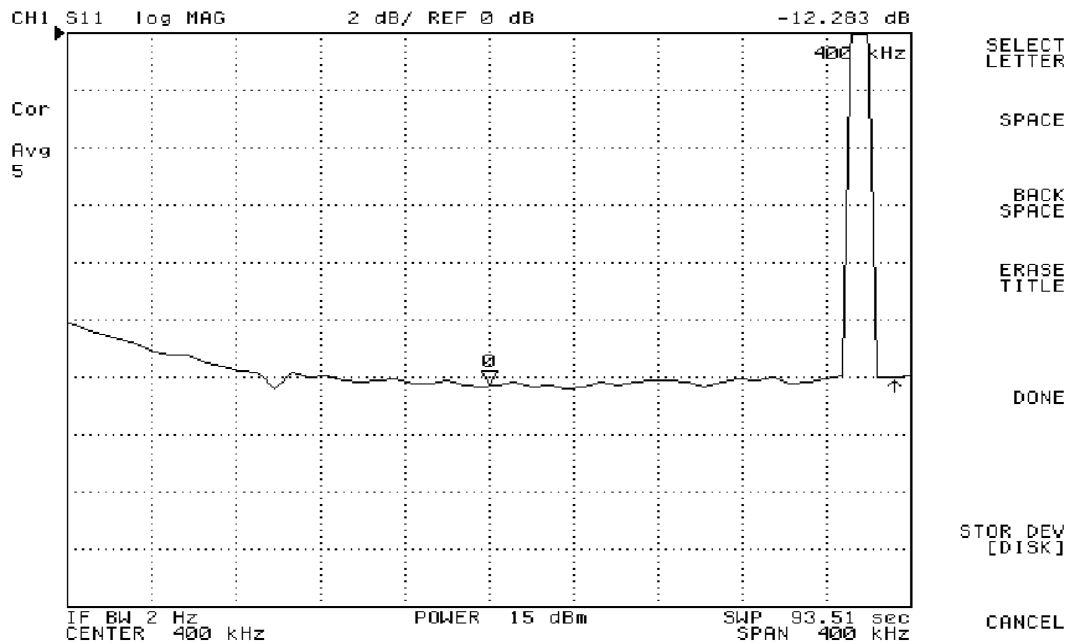

Figure 82: Example of test report

G1.5 Test Set-up for Interface 'C6'

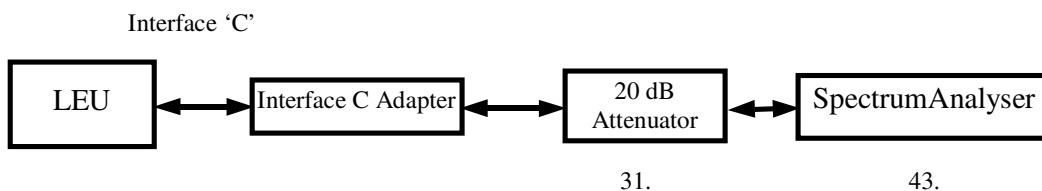

Figure 83: Test set-up for testing Interface 'C6' Return Loss

The Spectrum Analyser can be any commercial instrument ensuring the operation defined in the next sub-clause. In particular the used input port of the Spectrum Analyser shall be able to handle signal levels higher than or equal to 10 dBm. Suggested suitable equipment is found in clause F1 on page 297. Item 43 is suggested to be a Network Analyser configured as a Spectrum Analyser.

The 20 dB Attenuator is the same as defined above for the test of the Interface 'C1' (see sub-clause G1.2 on page 303). It is connected to the input of the analyser (e.g., Port R of the Network Analyser).

The Interface C Adapter is mechanically and electrically similar to the one used for the test of Interface ‘C1’ (see sub-clause G1.2 on page 303). The exception is that the 70 Ω resistors shall be replaced by impedance components whose characteristics are as indicated in the following Table 59. See also allowance in sub-clause G1.2 regarding splitting of impedance into two separate parts.

Step number	Impedance type	Value	Tolerance	Connection	Nominal values for the overall impedance to be used for the evaluation
1	Resistors	60 Ω / 1 W	< 1 %	As in Figure 81	$R_1 \approx 60 \Omega$
2	Resistor	180 Ω / 1 W	< 1 %	As in Figure 81	$R_2 \approx 180 \Omega$
3	Resistor + Capacitor	120 Ω / 1 W- 165 nF / 50 V	< 1 % < 1 %	As in Figure 81 R/C in series	$R_3 \approx 120 \Omega$ $X_3 \approx -109.4 \Omega$

Table 59: Impedance values used for the test

Please observe that the actual impedance values should be measured before testing, and that the actual impedance should be used in the subsequent calculation according to sub-clause G1.7 on page 307 (otherwise the accuracy might not be sufficient).

The link between the LEU output and the Network analyser (all included) shall not be longer than three meters.

G1.6 Calibration of the test set-up for Interface ‘C6’

It is required that all the components used for the test are measured within the 8 to 9 kHz range prior to the test. Their values shall be used in the evaluation defined hereafter instead of the nominal values of Table 59.

The measurement of the impedance of R_1 , R_2 , Z_3 , and Z_0 shall be done according to the following procedure (refer to the diagram in Figure 84). The impedance can be measured by the use of the same Network Analyser recalled above or by other equivalent instruments.

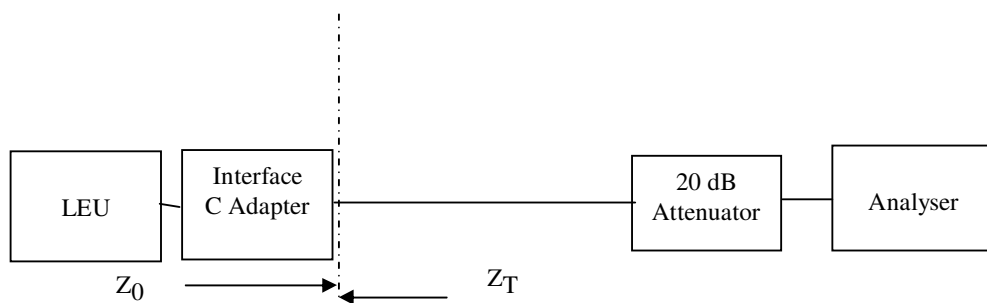

Figure 84: Layout for Test Impedance Calibration

- Step1. Measure the impedance $Z_0 (= R_0 + jX_0)$ at the connector of the Interface C Adapter on the Analyser side, with a 50 Ω termination connected to the output port of the attenuator (simulating the Analyser impedance).
- Step2. Measure the impedance Z_T (i.e. the value of R_1 , R_2 and $Z_3 (= R_3 + j X_3)$) at the connector of the Interface C Adapter on the Analyser side, with a short-circuit placed at its LEU side connector.

The following settings are recommended for the measurement layout of Figure 4, using the Network Analyser:

Measurement:	Spectrum R.
Format:	VOLT (RMS)
Centre freq.	8.82 kHz
Span	1 kHz
Freq. Resolution:	3 Hz
Ref. value:	500 mV
Vert. scale:	50 mV/div

After completion of the calibration, record the calibration status into a suitable medium for possible uses later on.

This test procedure requires the solution of a system of two non-linear equations that can be performed either analytically or by the use of a suitable mathematical tool. A simple evaluation program within the MAPLE environment is a suggested solution.

G1.7 Test Procedure for Interface ‘C6’

Connect the LEU, via the Interface C Adapter and the attenuator, to the input R of the network Analyser and switch it on. Perform the test for a long telegram (i.e., telegram number 18 from the list of Table 23 on page 162).

1. Set the test impedance of the Interface ‘C’ Adapter according to the indication of Table 59 for the current test step.
2. Command the LEU to transmit the test telegram.
3. Wait until the peak value of the spectrum is stable.
4. Record the final peak value of the spectrum in correspondence with the actual Interface ‘C6’ frequency (to be found within $8.82 \text{ kHz} \pm 0.1 \text{ kHz}$) on a suitable medium. Multiply the obtained values by the actual attenuation (nominally 10), in order to compensate for the 20 dB attenuation, and to obtain the values V_1 (1st step), V_2 (2nd step), and V_3 (3rd step) to be used in the Equation 1 and Equation 2 below.
5. Repeat steps 1 to 4 for the new test impedance, until the three test cases are completed.
6. Calculate the R_S and X_S values of the LEU output impedance at the Interface ‘C6’ frequency, by solving the system of Equation 1 and Equation 2, using the RMS voltage values (V_1 , V_2 and V_3 in Volt units) measured respectively at the 1st, 2nd and 3rd step. The actual load impedance values (R_1 , R_2 and R_3/X_3 in Ohm) apply for each calculation.
7. Use the Equation 3 for calculating the final Return Loss value. Check that the obtained value is above the minimum specified limit.

The following equivalent circuit and related equation system (applicable to Interface ‘C6’ measurements) shall be used for the calculations:

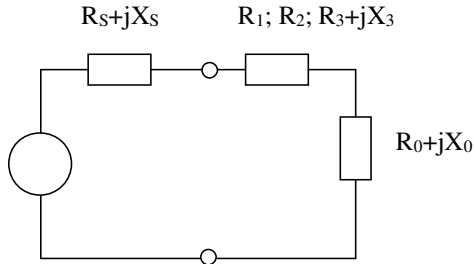

Figure 85: Equivalent circuit for evaluation of the Return Loss at Interface ‘C6’

Equation 1
$$k_1 = \frac{V_1^2}{V_2^2} = \frac{(R_2 + R_S + R_0)^2 + (X_S + X_0)^2}{(R_1 + R_S + R_0)^2 + (X_S + X_0)^2}$$

Equation 2
$$k_2 = \frac{V_1^2}{V_3^2} = \frac{(R_3 + R_S + R_0)^2 + (X_S + X_0 + X_3)^2}{(R_1 + R_S + R_0)^2 + (X_S + X_0)^2}$$

Equation 3
$$\text{Ret.Loss}_{C6} = -10 \cdot \log_{10} \left[\frac{(R_S - 170)^2 + X_S^2}{(R_S + 170)^2 + X_S^2} \right]$$

G2 Harmonic contents on the Interface ‘C6’ LEU output

In SUBSET-036, it is explicitly specified that harmonics within the frequency band 0.1 MHz to 1 MHz shall be below a certain value. For the purpose of LEU testing, this is judged being sufficiently verified through fulfilling the eye diagram for Interface ‘C1’.

For the purpose of measuring the eye diagram, filtering of the signal at the LEU output should be performed using a filter blocking the Interface ‘C6’ signal with the following characteristics:

- Type: Notch filter
- Attenuation relative to Interface ‘C1’ pass band:
 - At Interface ‘C6’ fundamental frequency ≥ 50 dB
 - At third Interface ‘C6’ overtone ≤ 2 dB
 - At fifth Interface ‘C6’ overtone and up to 100 kHz ≤ 1 dB

Annex H (Informative), Air-gap Reference Equipment

H1 General

This informative Annex includes recommended implementations of the air-gap reference equipment. It includes specific implementations for the Reference Loops, Test Antennas, Activation Antennas, and Baluns suitable for performing the tests defined within this specification. Other implementations are allowed, but the requirements of Annex B shall be fulfilled, and the accuracy shall be at least as good as achieved with the implementations recommended within this Annex.

H2 Reference Loops

H2.1 Reference Loop Design

H2.1.1 Overall Design

The Reference Loop is a conductor formed as a loop surrounding the active Reference Area. For several reasons, the Reference Loop shall be tuned. This provides better measurement accuracy, it decreases the sensitivity to E-field, and ensures that the current follows the border of the Reference Area.

The Reference Loop has to be tuned for two frequency bands. For measuring the output from the Antenna, the Reference Loop shall be tuned to 27.095 MHz. When generating a field equivalent to a Balise output field, the Reference Loop shall be tuned to 4.23 MHz. In these cases, tuning means that the input reactance of the Reference Loop shall be minimised (close to zero).

The Standard Size Reference Loop shall be designed according to the overall configuration shown in Figure 86. The metallic parts of the Reference Loop shall be made of solid copper. These parts shall be insulated from each other, and connected via printed circuit boards with the components according to Figure 88.

The Reduced Size Reference Loop shall include four sections, instead of eight as for the Standard Size Reference Loop. See Figure 87.

C_1 , L_2 and C_2 shall be mounted on the small PCB. L_1 in Figure 88 is the inductance of one of the Reference Loop sections. The total Reference Loop inductance L has to be determined (measured) before the tuning process. L_1 is then 1/4:th of L for the Reduced Size Reference Loop, and 1/8:th of L for the Standard Size Reference Loop. The component values shall be chosen so that the impedance of C_2 can be neglected for low frequencies, and the impedance of C_1 can be neglected for high frequencies. These assumptions give the following equations for the two resonance frequencies:

$$\omega_1 = \sqrt{\frac{1}{(L_1 + L_2) \cdot C_1}} \quad (4.23 \text{ MHz}) \quad \omega_2 = \sqrt{\frac{L_1 + L_2}{L_1 \cdot L_2 \cdot C_2}} \quad (27.095 \text{ MHz})$$

This Reference Loop will provide a 1 dB bandwidth of approximately 2 MHz for each frequency band. The inductance L_2 shall be an air wound coil with an inductance approximately equal to L_1 . C_1 and C_2 shall be porcelain or ceramic chip capacitors (with a temperature coefficient close to zero).

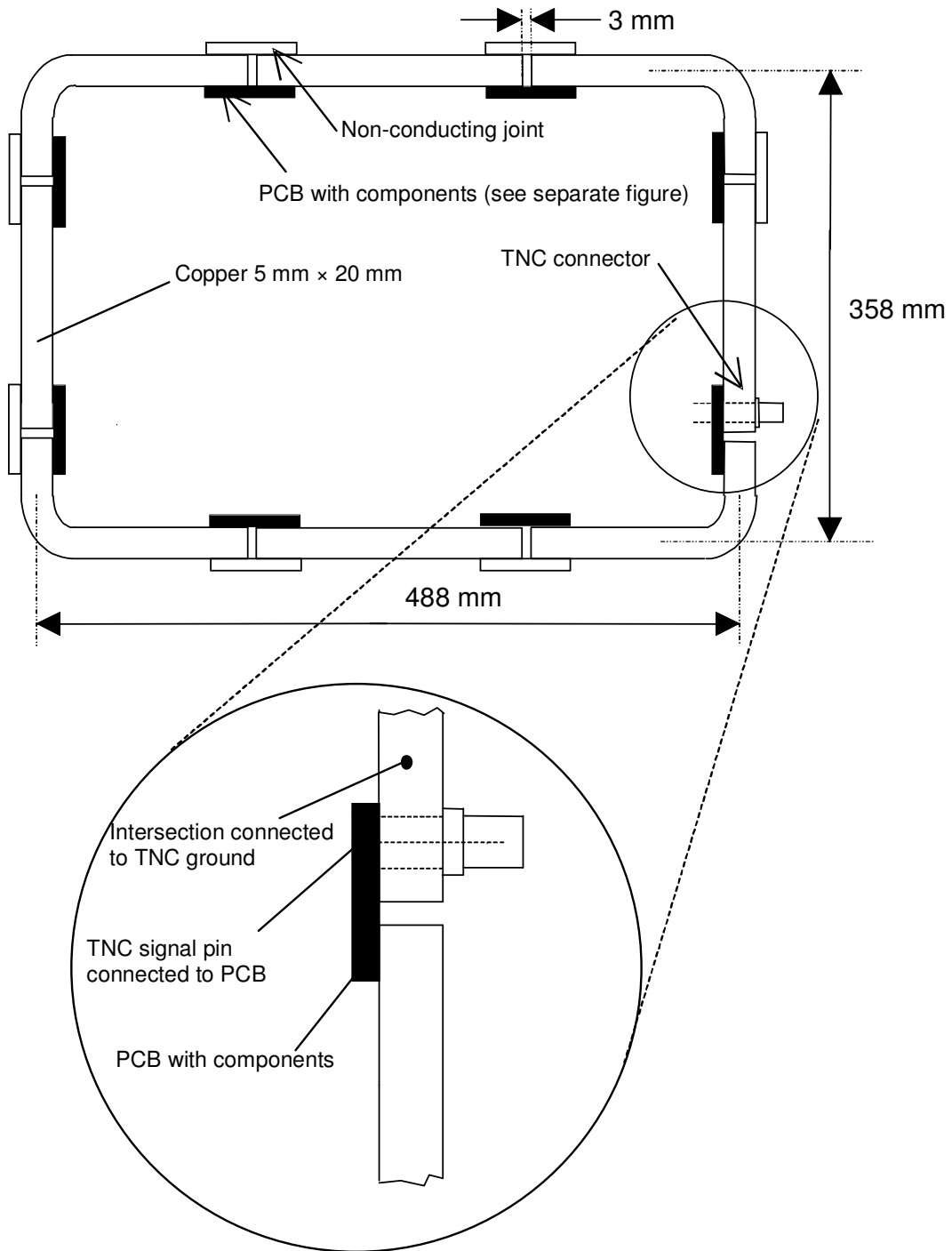

Figure 86: Standard Size Reference Loop, overall configuration

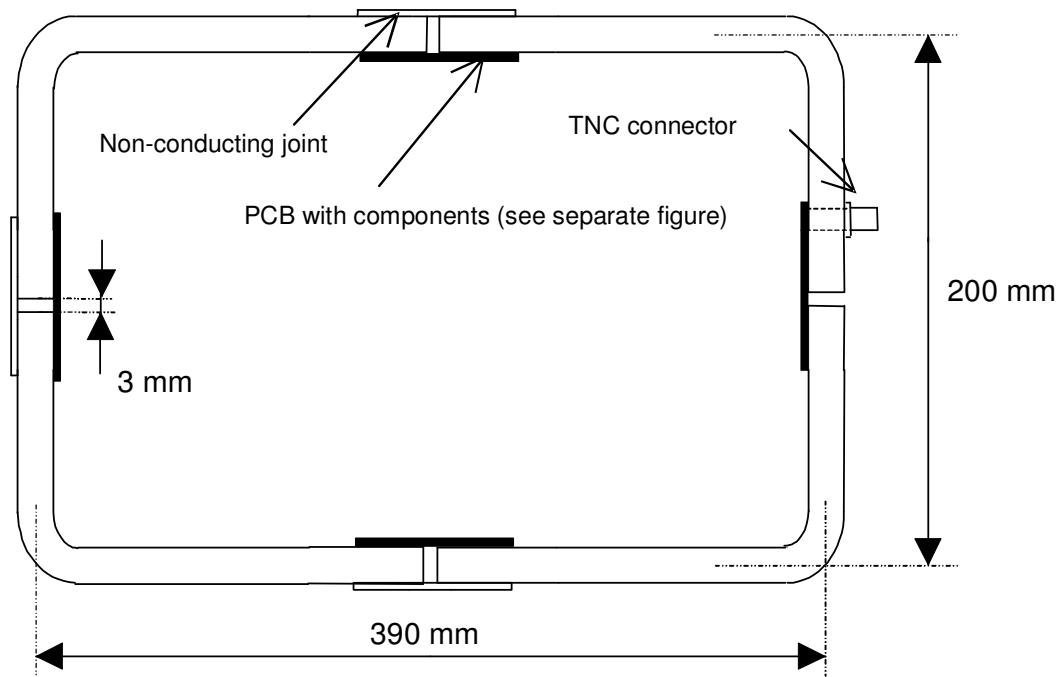

Figure 87: Reduced Size Reference Loop, overall configuration

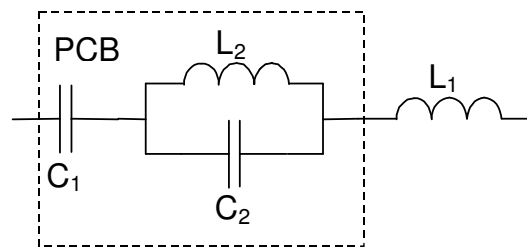

Figure 88: Printed Circuit Board (PCB) components within dashed box

H2.1.2 Loop Structure Mechanics

The following separate sections of the Loop (denominated “loop element”) are included:

- The right angle loop elements for the standard size loop (four in total).
- The straight loop elements for the standard size loop without holes for the TNC connector (three in total).
- The straight loop element for the standard size loop with holes for the TNC connector.
- The right angle loop elements for the reduced size loop without holes for the TNC connector (three in total).
- The right angle loop element for the reduced size loop with holes for the TNC connector.

See Figure 86 on page 310 and Figure 87 on page 311.

H2.1.3 Non-conductive Joints

There is a non-conductive washer used within the non-conductive joints between the Loop Elements.

The same washer is used for both types of Reference Loops. Seven washers are used in the Standard Size Reference Loop, and three in the Reduced Size Reference Loop.

The washers shall be mounted to the Loop Elements using M5 screws (four screws in each washer).

H2.1.4 Printed Circuit Board

Two types of printed circuit boards (PCBs) exist. One type shall be used where connection to the TNC connector is required, and the other type shall be used in all the other positions.

The PCBs shall be mounted to the loop elements using screws. Underneath the screw heads, a flat washer shall be mounted in order to ensure reliable electrical connection, and also to ensure that the PCB is not scratched during the assembly process. Screws and washers shall be made of nickel-plated brass.

The surface of the PCB facing the Loop Element shall be plated and connected to the component side through many plated via holes. This together with the screw mounting will ensure a low impedance connection.

H2.1.5 PCB Components

The components shown within the dashed box of Figure 88 on page 311 shall be determined in accordance with sub-clause H2.3. It is important that the components are of low loss type, and that they are stable with respect to temperature variations and ageing.

The following types of components are recommended:

- L_2 shall be an air wound fixed RF inductor. The recommendation is the 132 Series from Coilcraft.
- C_1 shall be a combination of three ceramic capacitors of low temperature coefficient type. The recommendation is the ATC700 Series from American Technical Ceramics Corp.
- C_2 shall be a combination of three porcelain capacitors of low temperature coefficient type. The recommendation is the ATC710 (or ATC700) series from American Technical Ceramics Corp.

Considering experience, the following guidelines apply for the Standard Size Reference Loop:

- The total inductance L is approximately 960 nH for both 4.23 MHz and 27.095 MHz. Consequently, the loop element inductance L_1 is approximately 120 nH. Considering this, the Coilcraft inductor 132-09 with an inductance of 138 nH should be selected for the component L_2 .
- Using the appropriate equation in sub-clause H2.3 gives a theoretical capacitance for C_1 of 5.46 nF. Considering this, a parallel combination of two 2.2 nF and one 1.0 nF capacitor should be used. The recommended types are ATC700B222GP50X and ATC700B102GP50X.
- Using the appropriate equation in sub-clause H2.3 gives a theoretical capacitance for C_2 of 537 pF. Considering this, a parallel combination of two 220 pF and one 100 pF capacitor should be used. The recommended types are ATC710B221FP200X and ATC700B101GP500X.

Considering experience, the following guidelines apply for the Reduced Size Reference Loop:

- The total inductance L is approximately 640 nH at 4.23 MHz and 540 nH at 27.095 MHz. Consequently, the loop element inductance L_1 is approximately 160 nH at 4.23 MHz and 135 nH at 27.095 MHz. Considering this, the Coilcraft inductor 132-09 with an inductance of 138 nH should be selected for the component L_2 .
- Using the appropriate equation in sub-clause H2.3 gives a theoretical capacitance for C_1 of 4.73 nF. Considering this, a parallel combination of two 2.2 nF and one 330 pF capacitor should be used. The recommended types are ATC700B222GP50X and ATC700B331GP200X.
- Using the appropriate equation in sub-clause H2.3 gives a theoretical capacitance for C_2 of 505 pF. Considering this, a parallel combination of two 220 pF and one 68 pF capacitor should be used. The recommended types are ATC710B221FP200X and ATC700B680GP500X.

It must be observed that the tuning process according to sub-clause H2.3 shall be followed, and that the component values above are guidelines only. The PCBs also have space available for one extra tuning capacitor (in parallel with the above described combinations for C_1 and C_2 respectively).

H2.1.6 Encapsulation

The Reference Loop shall be protected with an insulating plate. The total thickness of this plate shall be 27 mm, and the physical interface with the environment in the other directions (x and y) shall be 22 mm outside the Reference Area.

This means that the outer dimensions of the encapsulated Reference Loop shall be:

Standard Size Reference Loop:	Width \times Length = 402 mm \times 532 mm
Reduced Size Reference Loop:	Width \times Length = 244 mm \times 434 mm

The Reference Loop shall have visible markings that define the geometrical centre position of the Reference Area. It shall be located in the centre of the plate ± 10 mm.

H2.2 Utilisation of the Reference Loops

The Reference Loop shall be connected to the measuring equipment or signal source using a double shielded RG214 cable. At the end of the cable, close to the Reference Loop, there shall be a Balun connected. The cable shall be de-bugged using ferrite blocks evenly spaced at distances less than 70 cm. The core material in the ferrite blocks shall be "Amidon 43". The Balun design is described in clause H5 of this Annex.

It is important that the signal source feeding the Reference Loop (via the Balun) has a well-defined impedance. The same applies to the measuring equipment connected to the Reference Loop (via the Balun). The signal source and the measuring equipment nominal impedance shall both be 50 Ω .

This Reference Loop design will provide the following maximum impedance for the respective frequency bands:

- | | |
|---|-----------------|
| • Standard Size Reference Loop 4.23 MHz | max. 2 Ω |
| • Standard Size Reference Loop 27.095 MHz | max. 5 Ω |
| • Reduced Size Reference Loop 4.23 MHz | max. 1 Ω |
| • Reduced Size Reference Loop 27.095 MHz | max. 5 Ω |

Detailed instructions for utilisation of the Reference Loops are given in applicable sub-clauses of this specification.

H2.3 Tuning of the Reference Loops

As part of the manufacturing process, the Reference Loops have to be electrically tuned. The following procedure shall be used. An acceptably tuned Reference Loop shall provide an absolute value of the reactance that is less than the resistance (at 4.23 MHz and 27.095 MHz).

1. Temporarily short-circuit all components on the PCBs connecting the sections of the loop structure (e.g., use a special set of PCBs with short circuits instead of components).
2. Determine the total inductance of the loop structure. This is 'L' described in sub-clause H2.1.
3. Calculate L_1 . This is the inductance of each section of the loop structure.

$$\text{Standard Size Reference Loop: } L_1 = \frac{L}{8}$$

$$\text{Reduced Size Reference Loop: } L_1 = \frac{L}{4}$$

4. Determine L_2 using the following equation: $L_2 \approx L_1$

5. Determine C_1 using the following equation:
$$C_1 = \frac{1}{4\pi^2 \cdot f_1^2 \cdot (L_1 + L_2)}$$

where $f_1 = 4.23$ MHz.

6. Determine C_2 using the following equation:
$$C_2 = \frac{L_1 + L_2}{4\pi^2 \cdot f_2^2 \cdot L_1 \cdot L_2}$$

where $f_2 = 27.095$ MHz.

7. Measure the actual impedance at 4.23 MHz with all the components determined above mounted on the PCBs (and attached to the Loop Elements). If the absolute value of the reactance is not less than the resistance, then C_1 has to be adjusted accordingly.
8. Measure the actual impedance at 27.095 MHz with all the components determined above mounted on the PCBs (and attached to the Loop Elements). If the absolute value of the reactance is not less than the resistance, then C_2 has to be adjusted accordingly.

H2.4 Calibration of the Reference Loops

The Reference Loops will have imperfections caused by the manufacturing process. The calibration procedure shall determine relevant calibration factors that are to be associated with each individual Reference Loop.

Three Reference Loops of the same kind shall be measured in accordance with sub-clause B2.6 of Annex B on page 173. Thereafter, the differences between the theoretical and the measured values shall be allocated to each individual Reference Loop using the following equations:

$$\begin{aligned}\epsilon_1 &= \frac{a_{12} + a_{13} - a_{23} - a_0}{2} \\ \epsilon_2 &= \frac{a_{12} + a_{23} - a_{13} - a_0}{2} \\ \epsilon_3 &= \frac{a_{13} + a_{23} - a_{12} - a_0}{2}\end{aligned}$$

where: a_{12} = measured attenuation between loop 1 and loop 2
 a_{13} = measured attenuation between loop 1 and loop 3
 a_{23} = measured attenuation between loop 2 and loop 3
 a_0 = theoretical attenuation between two loops
 ϵ_1 = error of loop 1
 ϵ_2 = error of loop 2
 ϵ_3 = error of loop 3

An alternative is to make a measurement between two Reference Loops, where one of these is an already characterised device, and the other is the device to be calibrated.

The next step is to calculate the difference between the electrical centre of the device and the geometrical centre (marked on the Reference Loop). The method for this is to minimise the standard deviation and the average of the measurement errors for the Reference Loop in question. The minimisation is performed by means of simulating a displacement in x, y, and z co-ordinates based on the derivatives of the field distribution (in dB/cm). A change of the electrical size of the Reference Loop should also be simulated (this is the 'B'-factor in sub-clause B2.3 of Annex B on page 171). The results of this process shall be marked on the Reference Loop.

The impedance of the Reference Loop during free air conditions shall also be measured and marked on the Reference Loop.

H3 Test Antennas

H3.1 General

In addition to the Standard Test Antenna, hereafter simply denominated Test Antenna, there is a need for a Modified Test Antenna. This modified design is identical to the standard design except for including a 200 mm by 200 mm 4.23 MHz loop only (no 27.095 MHz loop). See sub-clause H3.3 on page 320. The reason is that there are certain tests required during Balise conformity tests that require that there is no distortion of the Tele-powering field. In order to minimise the presumptive distortion, the 27.095 MHz loop is removed.

It shall be observed that the Test Antenna **shall always have a 50 Ω load on the current sense output.**

The herein-described implementation provides the possibility to handle a maximum input power resulting in a current sense output of up to 7.4 dBm.

The reference point of the Test Antennas is in the middle of the conductor of the 27 MHz loop element (z-direction), and at the centre of the loop element in the x-y plane. In case there is only a 4.2 MHz loop element (i.e., in the Modified Test Antenna), the definition applies to this loop element.

H3.2 Test Antenna Design

H3.2.1 Overall Design

The overall mechanical configuration shall be according to Figure 89 below. Please note that the details are not to scale. Details in red colour indicate water protection (see sub-clause 4.2.4.1 on page 47).

“Bottom” view

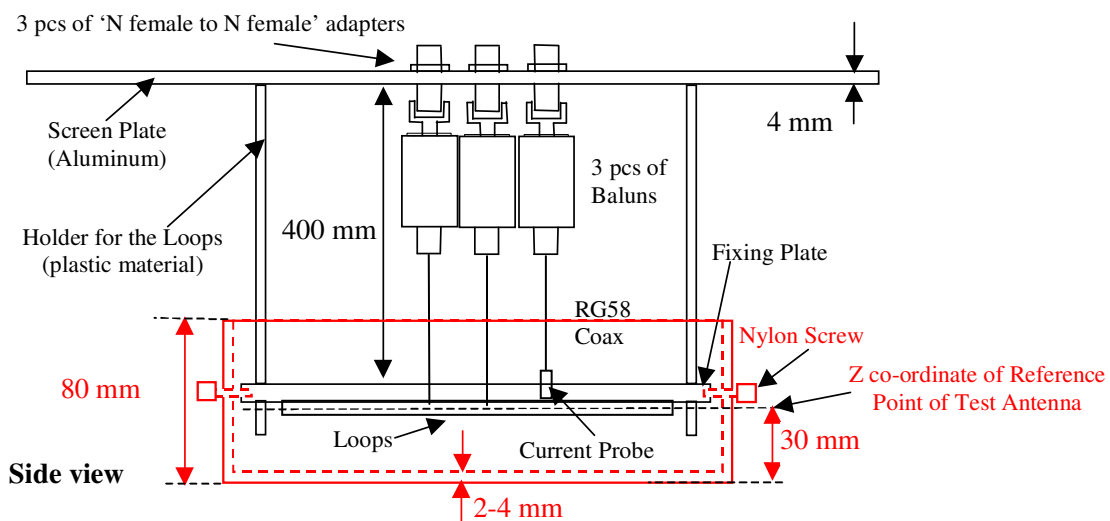
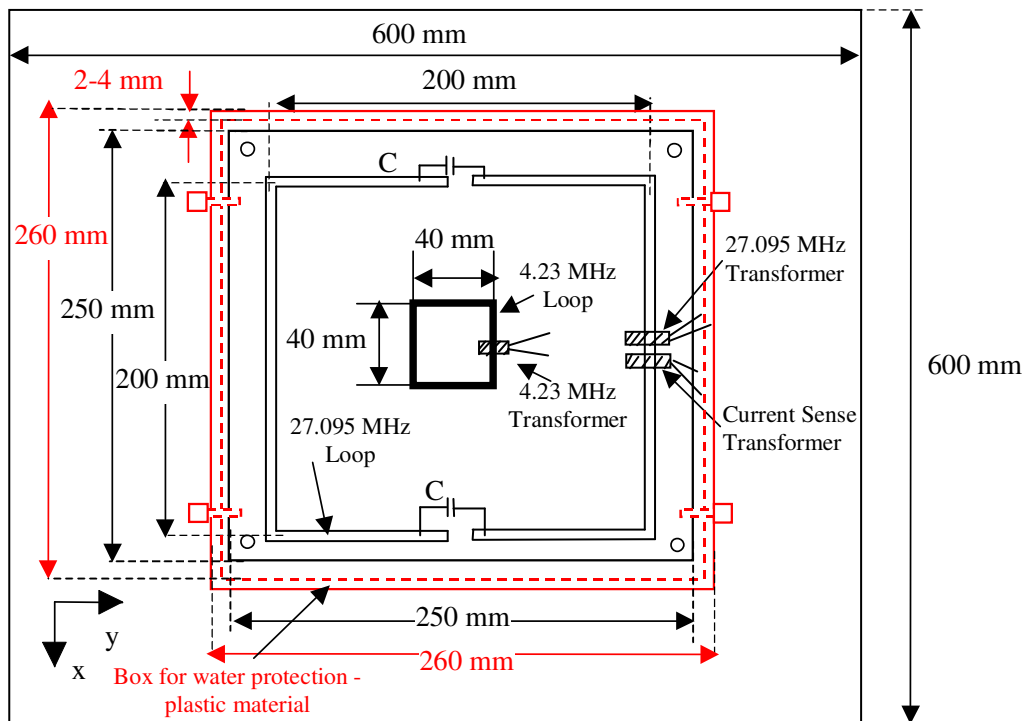

Figure 89: Overall Mechanical Layout

H3.2.2 Screen Plate

The screen plate (of dimensions 600 mm × 600 mm and 4 mm thick) shall be made of aluminium. The purpose of the plate is to reduce environmental influence. The screen plate also holds the three 'N female to N female' adapters. The adapters shall be located directly above the respective transformer they are connected to (in both x and y co-ordinates).

H3.2.3 Holder

The holders shall be made of plastic material (polyvinyl chloride), and rigidly support the antenna loops (mounted on a fixing plate). The holders shall be positioned so that the Loops are at a 400 mm distance from the screen plate, and centred with respect to this. The dimension of the holders should be ϕ 25 mm. The holders are built up of two separate details.

H3.2.4 Loops

H3.2.4.1 General

The cross-section of the 27.095 MHz loop shall be 10 mm × 20 mm, and the inner radius in the corners shall be approximately 10 mm. The cross-section of the 4.23 MHz loop shall be ϕ 2 mm, and the inner radius in the corners shall be approximately 5 mm.

The loops shall be mounted on a fixing plate (of polyvinyl chloride), and the 27.095 MHz loop should be made of solid copper. The 4.23 MHz loop should be made of solid brass.

H3.2.4.2 Capacitors

The capacitors in the 27.095 MHz loop (C in Figure 89) shall be mounted on small PCBs, which are directly connected the loop by screw mounting. Each C should be a combination of fixed surface mounted devices, and one variable capacitor (denominated C₁ and C₂). It is important that the capacitors are of high-Q type, and that they withstand at least 500 V. They shall also be able to withstand a current of at least 4 A.

The following types of components are strongly recommended:

- C₁ shall be a combination of four porcelain capacitors of low temperature coefficient type. The recommendation is the ATC710 (or ATC700) series from American Technical Ceramics Corp.
- C₂ shall be a variable ceramic capacitor of low temperature coefficient type. The recommendation is the Gigahertz Trimmer Capacitor series from Tekelec Temex.

Considering experience, the following guidelines apply:

- For C₁ a parallel combination of three 43 pF and one 39 pF capacitors should be used. The recommended types are ATC700B430GP500X and ATC700B390GP500X.
- For C₂ a variable capacitor with a capacitance range of 0.8 pF to 8.0 pF should be used. The recommended type is AT27291.

It must be observed that the tuning process according to sub-clause H3.4 on page 320 shall be followed, and that the component values above are guidelines only. The PCBs also have space available for one extra tuning capacitor (in parallel with the above described combination of C₁ and C₂).

H3.2.4.3 Printed Circuit Board (PCB)

The capacitors (C in Figure 89) shall be mounted on PCBs.

The PCBs shall be mounted to the loop elements using screws. Underneath the screw heads a flat washer shall be mounted in order to ensure reliable electrical connection, and also to ensure that the PCB is not scratched during the assembly process.

The surface of the PCB facing the loop element shall be plated and connected to the component side through many plated via holes. This together with the screw mounting will ensure a low impedance connection.

H3.2.4.4 27.095 MHz Transformer

The transformer shall have a primary winding of 6 turns. The secondary winding shall be the loop itself (1 turn).

It is important that all unshielded wires connected to the transformer are twisted (with a maximum open loop area of much less than 0.5 cm^2).

The core material should be “Philips violet” (material 4C65), and the inner diameter of the core shall be approximately 25 mm (type RCC 36/25/15 is recommended). The $10 \text{ mm} \times 20 \text{ mm}$ loop structure shall not interfere with the inner diameter of the core.

H3.2.4.5 Current Sense Transformer and Current Probe

The transformer shall have a primary winding of 8 turns. The secondary winding shall be the loop itself (1 turn). The primary winding shall be short-circuited, and the wire shall pass through the current probe (see Figure 90).

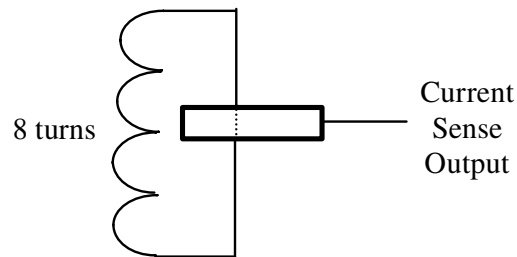

Figure 90: Current Sense Transformer

It is important that all unshielded wires connected to the transformer are twisted (with a maximum open loop area of much less than 0.5 cm^2).

The core material should be “Philips violet” (material 4C65), and the inner diameter of the core shall be approximately 25 mm (type RCC 36/25/15 is recommended). The $10 \text{ mm} \times 20 \text{ mm}$ loop structure shall not interfere with the inner diameter of the core.

The current probe is a passive device. The recommended part is the High Frequency Current Probe CT-2 from Tektronix.

The Current Probe provides a calibrated output voltage of approximately 1 mV/mA .

H3.2.4.6 4.23 MHz Transformer

The transformer shall have a primary winding of 7 turns (the Modified Test Antenna 5 turns). The secondary winding shall be the loop itself (1 turn).

It is important that all unshielded wires connected to the transformer are twisted (with a maximum open loop area of much less than 0.5 cm²).

The core material should be “Philips pink” (material 4A11), and the core outer diameter shall be approximately 15 mm (type RCC 16/9.6/6.3 is recommended). The core shall have an A_l value that is significantly higher than the loop inductance (which has been estimated to be approximately 40 nH).

H3.2.5 Balun

There is a need for baluns as close as possible to the Test Antenna. The core shall have high impedance for the frequency range 3 MHz to 30 MHz. The recommendation is to use the General Purpose Balun defined by sub-clause H5.2 on page 327.

H3.3 Modified Test Antenna Design

The Modified Test Antenna does not include the 27.095 MHz loop. This is the main difference between the (Standard) Test Antenna and the Modified Test Antenna. Consequently, parts such as 27.095 MHz transformer, current sense transformer, current probe, and the related baluns are not required (and are removed). To improve the measurement repeatability, the fixing plate is replaced with another fixing plate with a bigger 4.23 MHz loop that is 200 mm x 200 mm.

The 4.23 MHz transformer shall have a primary winding of 5 turns. The secondary winding shall be the loop itself (1 turn).

Apart from this, the Modified Test Antenna is identical to the Test Antenna. Because of not having a 27.095 MHz loop, the Modified Test Antenna is not tuned.

Because of the modular design of the Test Antenna, the Modified Test Antenna may be realised by simply substituting the original fixing plate with another fixing plate equipped with a bigger 4.23 MHz loop.

H3.4 Tuning of Test Antenna

As part of the manufacturing process, the Test Antenna has to be electrically tuned.

The tuning (using the capacitors mounted on the PCBs) shall be performed by means of maximising the signal from the current sense output, when the Test Antenna is supplied with a constant 27.095 MHz signal, and when keeping the Test Antenna subjected to free air conditions.

H3.5 Performance Check of Test Antenna

After having performed tuning according to sub-clause H3.4 on page 320, and verified compliance with mechanical tolerances, the Test Antenna shall be tested according the following when supplied with a constant 27.095 MHz signal. The actual impedance of the Reduced Size Reference Loop shall be taken into account.

- A Reduced Size Reference Loop shall be positioned at $[x = 0, y = 0, z = 220 \text{ mm}]$ relative to the Test Antenna, and connected to a resistive 50Ω load. The attenuation from the current sense output (loaded with 50Ω) to the output of the Reduced Size Reference Loop shall be $30 \text{ dB} \pm 2 \text{ dB}$.
- A Reduced Size Reference Loop shall be positioned at $[x = 0, y = 0, z = 220 \text{ mm}]$ relative to the Test Antenna. The variation in attenuation from the current sense output (loaded with 50Ω) to the output of the Reduced Size Reference Loop shall not exceed $\pm 0.5 \text{ dB}$ when the load of the Reduced Size Reference Loop is within the resistance range 20Ω to 50Ω (resistive loads) ³³.
- A Reduced Size Reference Loop shall be positioned at $[x = 0, y = 0, z = 460 \text{ mm}]$ relative to the Test Antenna, and connected to a resistive 50Ω load. The attenuation from the input forward current into the Test Antenna to the output of the Reduced Size Reference Loop shall be $15 \text{ dB} \pm 2 \text{ dB}$. It shall be observed that the current sense output of the Test Antenna must be loaded with 50Ω .

³³ The procedure for performing measurements with loads not equal to 50Ω requires special precautions. A method and suitable equipment is described in sub-clause 4.2.6 on page 67.

H4 Activation Antennas

H4.1 General

In addition to the Activation Antenna, there is a need for a modified design, hereafter called 4.2 MHz Antenna, which is used as a probe during certain Balise conformity tests. This modified design is identical to the Activation Antenna except for including a 4.23 MHz loop instead of a 27.095 MHz loop. The reason is that there are certain tests required during Balise conformity tests that require that there is no distortion of the Tele-powering field when at the same time measuring the Up-link signal.

It shall be observed that the Activation Antenna **shall always have a 50 Ω load on the Current Sense output.**

The herein-described implementation provides the possibility to handle a maximum input power resulting in a current sense output of up to 7.4 dBm.

The reference point of the Activation Antennas is in the middle of the conductor of the 27 MHz loop element (z-direction), and at the centre of the loop element in the x-y plane. In case there is only a 4.2 MHz loop element (i.e., in the 27 MHz Antenna), the definition applies to this loop element.

H4.2 Activation Antenna Design

H4.2.1 Overall Design

The overall mechanical configuration shall be according to Figure 91 below. Please note that the details are not to scale.

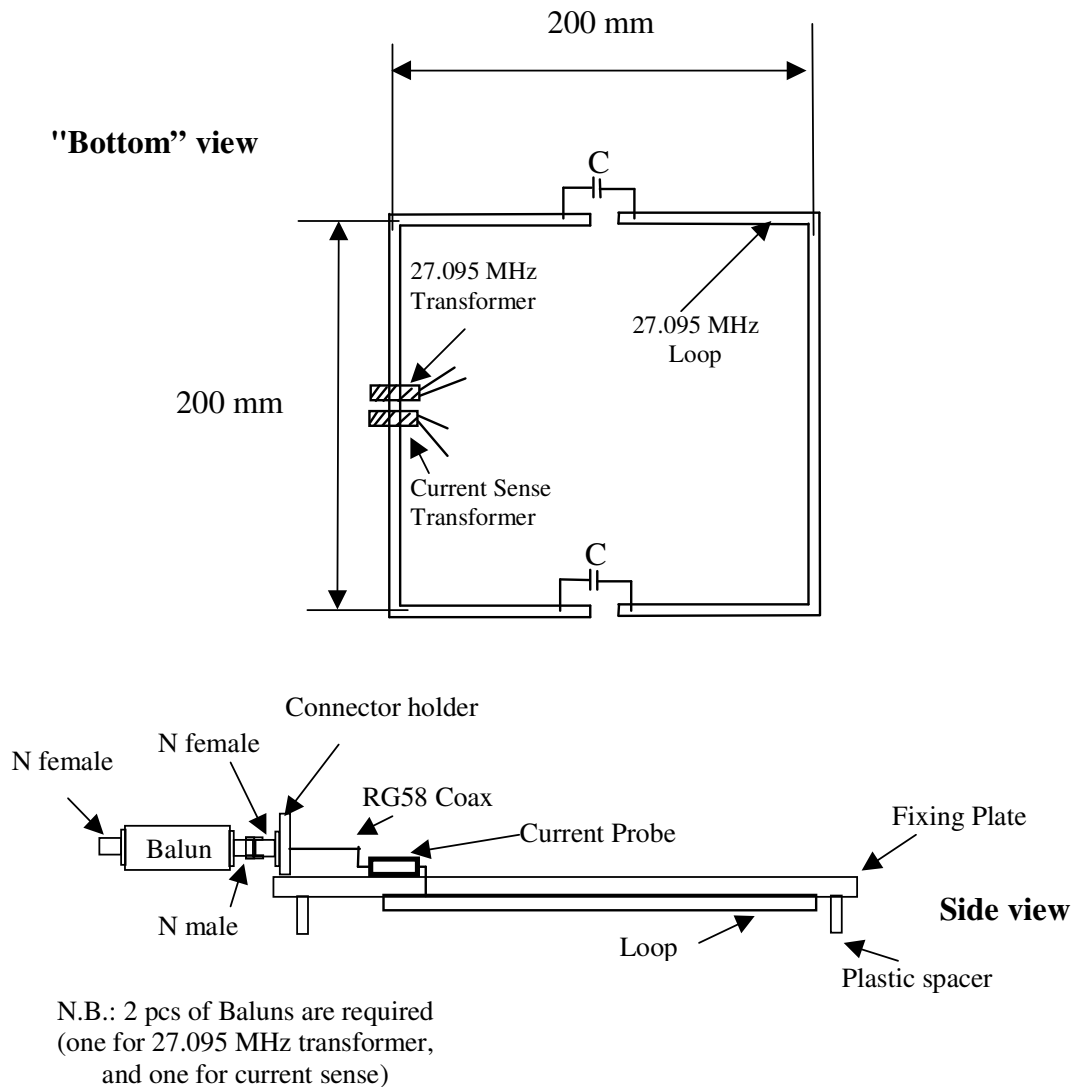

Figure 91: Overall Mechanical Layout

H4.2.2 Spacer

The spacer shall be made of plastic material (polyvinyl chloride). The dimension of the Spacer should be ϕ 25 mm.

H4.2.3 Loop

H4.2.3.1 General

The cross-section of the 27.095 MHz loop shall be 10 mm \times 20 mm, and the inner radius in the corners shall be approximately 1 cm.

The loop shall be mounted on a fixing plate (of polyvinyl chloride), and the 27.095 MHz loop should be made of solid copper.

H4.2.3.2 Capacitors

The capacitors in the 27.095 MHz Loop (C in Figure 91) shall be mounted on small PCBs, which are directly connected to the loop by screw mounting. Each C should be a combination of fixed surface mounted devices, and one variable capacitor (denominated C_1 and C_2). It is important that the capacitors are of high-Q type, and that they withstand at least 500 V. They shall also be able to withstand a current of at least 4 A.

The following types of components are strongly recommended:

- C_1 shall be a combination of four porcelain capacitors of low temperature coefficient type. The recommendation is the ATC710 (or ATC700) series from American Technical Ceramics Corp.
- C_2 shall be a variable ceramic capacitor of low temperature coefficient type. The recommendation is the Gigahertz Trimmer Capacitor series from Tekelec Temex.

Considering experience, the following guidelines apply:

- For C_1 a parallel combination of three 43 pF and one 39 pF capacitors should be used. The recommended types are ATC700B430GP500X and ATC700B390GP500X.
- For C_2 a variable capacitor with a capacitance range of 0.8 pF to 8.0 pF should be used. The recommended type is AT27291.

It must be observed that the tuning process according to sub-clause H4.4 on page 326 shall be followed, and that the component values above are guidelines only. The PCBs also have space available for one extra tuning capacitor (in parallel with the above described combination of C_1 and C_2).

H4.2.3.3 Printed Circuit Board (PCB)

The capacitors (C in Figure 91) shall be mounted on PCBs.

The PCBs shall be mounted to the loop elements using screws. Underneath the screw heads a flat washer shall be mounted in order to ensure reliable electrical connection, and also to ensure that the PCB is not scratched during the assembly process.

The surface of the PCB facing the loop element shall be plated and connected to the component side through many plated via holes. This together with the screw mounting will ensure a low impedance connection.

H4.2.3.4 27.095 MHz Transformer

The transformer shall have a primary winding of 6 turns. The secondary winding shall be the Loop itself (1 turn).

It is important that all unshielded wires connected to the transformer are twisted (with a maximum open loop area of much less than 0.5 cm^2).

The core material should be “Philips violet” (material 4C65), and the inner diameter of the core shall be approximately 25 mm (type RCC 36/25/15 is recommended). The $10 \text{ mm} \times 20 \text{ mm}$ loop structure shall not interfere with the inner diameter of the core.

H4.2.3.5 Current Sense Transformer and Current Probe

The transformer shall have a primary winding of 8 turns. The secondary winding shall be the Loop itself (1 turn). The primary winding shall be short-circuited, and the wire shall pass through the current probe (see Figure 92).

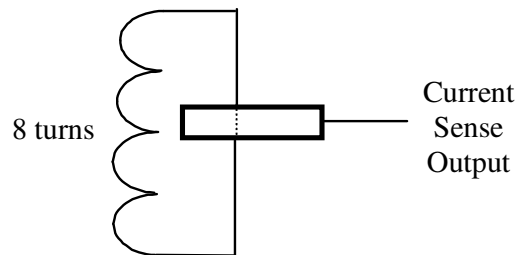

Figure 92: Current Sense Transformer

It is important that all unshielded wires connected to the transformer are twisted (with a maximum open loop area of much less than 0.5 cm^2).

The core material should be “Philips violet” (material 4C65), and the inner diameter of the core shall be approximately 25 mm (type RCC 36/25/15 is recommended). The $10 \text{ mm} \times 20 \text{ mm}$ loop structure shall not interfere with the inner diameter of the core.

The current probe is a passive device. The recommended part is the High Frequency Current Probe CT-2 from Tektronix.

The current probe provides a calibrated output voltage of approximately 1 mV/mA .

H4.2.4 Connector Holder

The Connector Holder shall be made of plastic material (polyvinyl chloride).

H4.2.5 Balun

There is a need for baluns as close as possible to the Activation Antenna. The core shall have high impedance for the frequency range 3 MHz to 30 MHz. The recommendation is to use the General Purpose Balun defined by sub-clause H5.2 on page 327.

H4.3 4.2 MHz Antenna Design

The 4.2 MHz Antenna does not include the 27.095 MHz loop but includes a 4.2 MHz loop. This is the main difference between the Activation Antenna and the 4.2 MHz Antenna. Consequently, parts such as 27.095 MHz transformer, current sense transformer, current probe, and the related baluns are not required, and are substituted by a 4.2 MHz loop and a 4.2 MHz transformer (together with a General Purpose Balun).

Parts related to the 4.2 MHz transformer are identical to the same design for the Test Antenna. The transformer shall have a primary winding of 7 turns. The secondary winding shall be the loop itself (1 turn). The core material should be “Philips pink” (material 4A11), and the core outer diameter shall be approximately 15 mm (type RCC 16/9.6/6.3 is recommended).

Because of not having a 27.095 MHz loop, the 4.2 MHz Antenna is not tuned.

H4.4 Tuning of Activation Antenna

As part of the manufacturing process, the Activation Antenna has to be electrically tuned.

The tuning (using the capacitors mounted on the PCBs) shall be performed by means of maximising the signal from the current sense output, when the Activation Antenna is supplied with a constant 27.095 MHz signal, and when keeping the Activation Antenna subjected to free air conditions.

H4.5 Performance Check of Activation Antenna

After having performed tuning according to sub-clause H4.4, and verified compliance with mechanical tolerances, the Activation Antenna shall be tested according the following when supplied with a constant 27.095 MHz signal. The actual impedance of the Reduced Size Reference Loop shall be taken into account.

- A Reduced Size Reference Loop shall be positioned at $[x = 0, y = 0, z = 220 \text{ mm}]$ relative to the Activation Antenna, and connected to a resistive 50Ω load. The attenuation from the current sense output (loaded with 50Ω) to the output of the Reduced Size Reference Loop shall be $30 \text{ dB} \pm 2 \text{ dB}$.
- A Reduced Size Reference Loop shall be positioned at $[x = 0, y = 0, z = 220 \text{ mm}]$ relative to the Activation Antenna. The variation in attenuation from the current sense output (loaded with 50Ω) to the output of the Reduced Size Reference Loop shall not exceed $\pm 0.5 \text{ dB}$ when the load of the Reduced Size Reference Loop is within the resistance range 20Ω to 50Ω (resistive loads)³⁴.
- A Reduced Size Reference Loop shall be positioned at $[x = 0, y = 0, z = 460 \text{ mm}]$ relative to the Activation Antenna, and connected to a resistive 50Ω load. The attenuation from the input forward current into the Activation Antenna to the output of the Reduced Size Reference Loop shall be $15 \text{ dB} \pm 2 \text{ dB}$. It shall be observed that the current sense output of the Activation Antenna must be loaded with 50Ω .

³⁴ The procedure for performing measurements with loads not equal to 50Ω requires special precautions. A method and suitable equipment is described in sub-clause 4.2.6 on page 67.

H5 Baluns

H5.1 General

This Annex is a Design Specification defining specific implementations of Reference Equipment Baluns. It includes a General Purpose Balun to be used together with Test Antennas, Activation Antennas and various instruments. A General Purpose Balun for Reference Loops, hereafter called Reference Loop Balun is also included. This device is intended to be connected to a Reference Loop (it is equipped with a TNC connector).

This Annex also includes a balun with Current Sense capabilities, hereafter called Current Sense Balun. This balun is mainly intended for use together with Reference Loops in order to enable a simplified test method (direct measurement of current instead of calculations based on Reference Loop impedance).

Please note that the figures of this document defining the overall configurations are not to scale.

H5.2 General Purpose Balun Design

H5.2.1 Overall Design

The General Purpose Balun consists of a toroid on which an RG58 coaxial cable is wound a sufficient amount of turns. This is placed inside a plastic box equipped with N connectors (one N male connector, and one N female connector). The toroid shall provide high impedance for the frequency range 3 MHz to 30 MHz.

The General Purpose Balun shall be designed according to the overall configuration shown in Figure 93.

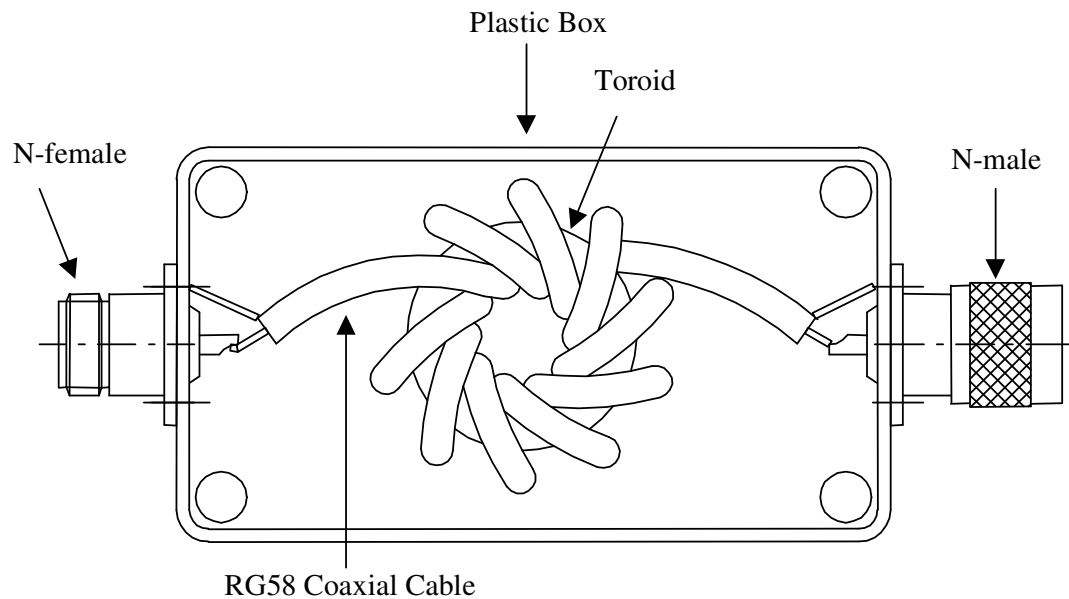

Figure 93: General Purpose Balun, Overall Configuration

H5.2.2 Toroid

The core material Amidon 77 is recommended, and the dimensions should be $\phi 35.6 \text{ mm} \times \phi 22.9 \text{ mm} \times 12.7 \text{ mm}$ (outer diameter \times inner diameter \times width). The recommended type is FT-140-77.

The RG58 coaxial cable should have 10 turns on the core. See Figure 93.

H5.3 Reference Loop Balun Design

H5.3.1 Overall Design

The differences between the Reference Loop Balun and the General Purpose Balun are as follows:

- A TNC male connector is used instead of the N male connector.
- The size of the plastic box is different.
- The device is equipped with support structures that fit together with a Reference Loop.

The Reference Loop Balun shall be designed according to the overall configuration shown in Figure 94.

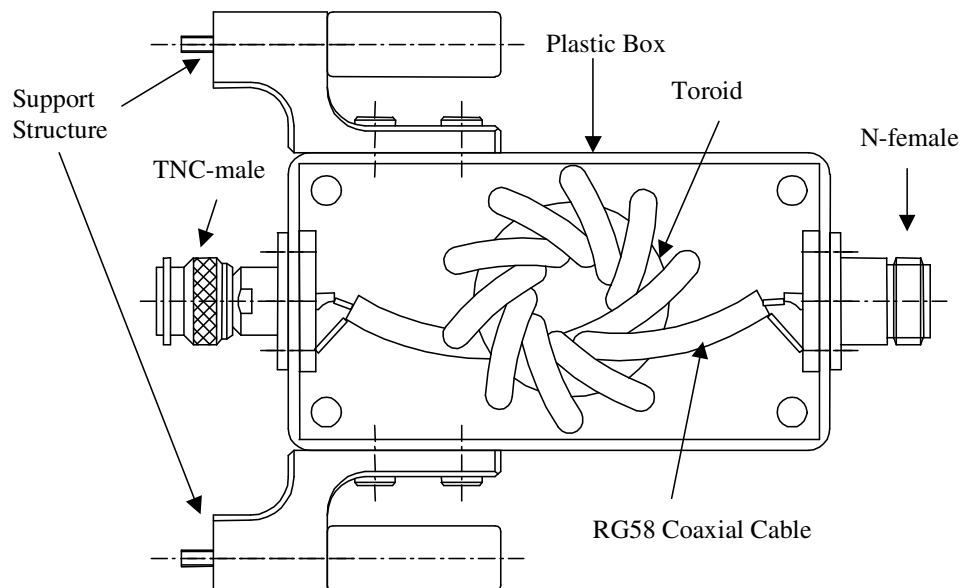

Figure 94: Reference Loop Balun, Overall Configuration

H5.3.2 Toroid

The core material Amidon 77 is recommended, and the dimensions should be $\phi 35.6 \text{ mm} \times \phi 22.9 \text{ mm} \times 12.7 \text{ mm}$ (outer diameter \times inner diameter \times width). The recommended type is FT-140-77.

The RG58 coaxial cable should have 10 turns on the core. See Figure 94.

H5.4 Current Sense Balun Design

H5.4.1 Overall Design

In order to provide current sense capabilities, the current sense balun shall be equipped with an additional current probe. This current probe shall be positioned inside a plastic box similar to the one used for the Reference Loop Balun.

The differences between the Current Sense Balun and the Reference Loop Balun are as follows:

- An additional N female connector is included.
- The size of the plastic box is different.
- The device is equipped with a Current Probe.

The Current Sense Balun shall be designed according to the overall configuration shown in Figure 95.

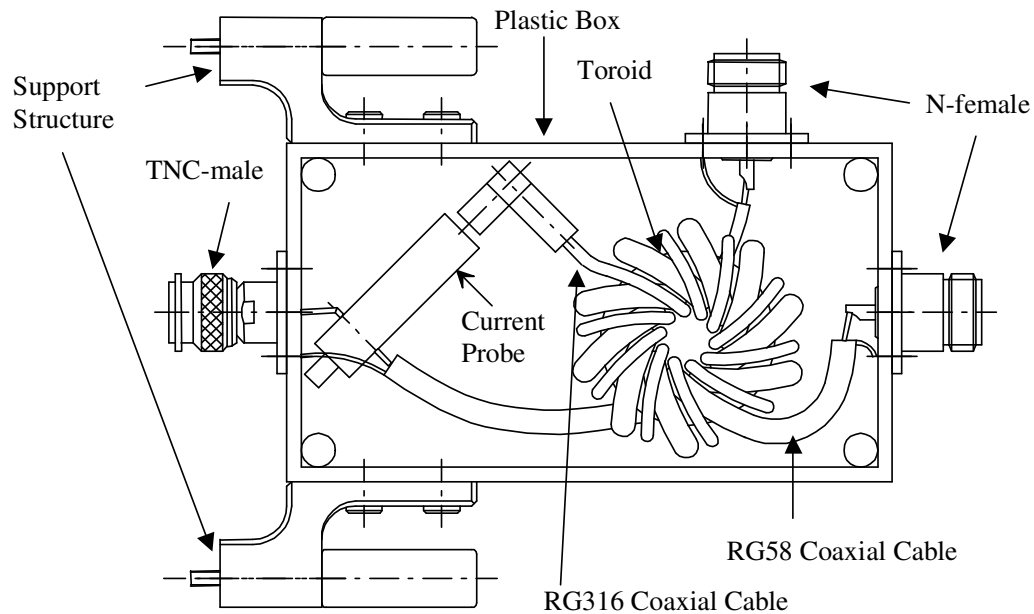

Figure 95: Current Sense Balun, Overall Configuration

The support for the current probe, and the current probe itself, shall be fixed in the box using suitable glue.

H5.4.2 Toroid

The core material Amidon 77 is recommended, and the dimensions should be $\phi 35.6 \text{ mm} \times \phi 22.9 \text{ mm} \times 12.7 \text{ mm}$ (outer diameter \times inner diameter \times width). The recommended type is FT-140-77.

The RG58 and RG 316 coaxial cables should have 10 turns on the core. See Figure 95.

H5.4.3 Current Probe

The current probe is a passive device. The recommended part is the High Frequency Current Probe CT-2 from Tektronix.

The current probe provides a calibrated output voltage of approximately 1 mV/mA.

H5.5 Calibration of the Current Sense Balun

The current probe from Tektronix is a factory calibrated device. The device is specified to provide 1 mV/mA with an accuracy of $\pm 4\%$.

This accuracy may not be sufficient for certain reference measurements. Therefore, it is recommended to calibrate the transfer function of the Current Probe using the below described procedure.

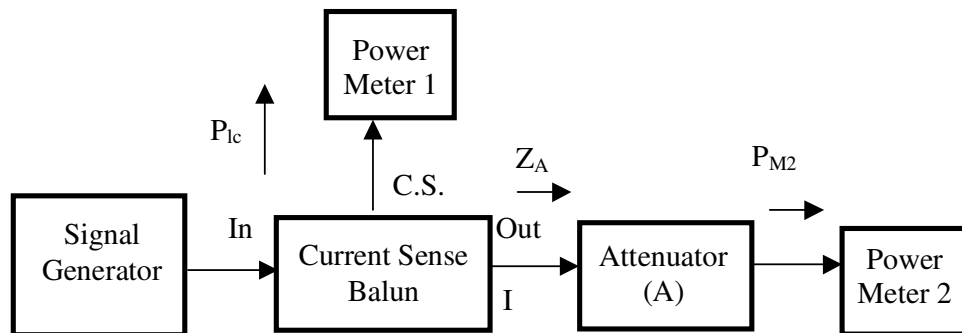

Figure 96: Current Sense Balun, Calibration set-up

The following equations are applicable:

$$1) I_0^2 = \frac{AP_{M2}}{|Z_A|}$$

$$2) k = \frac{P_{1c}}{AP_{M2}}$$

where P_{1c} is the power reading of Power Meter 1, P_{M2} is the power reading of Power Meter 2, A is the attenuation of the attenuator, I_0 is the current through the Current Sense Balun during calibration, Z_A is the input impedance of the attenuator, and k is the transfer ratio of the Current Sense Balun to be determined.

Thereafter, the following is valid for any current (below 2.5 A) through the Current Sense Balun loaded with an impedance of less than 100 Ω (connected to the output port):

$$3) I = \sqrt{\frac{P_{1c}}{k|Z_A|}}$$

where I is the actual current through the Current Sense Balun during actual measurements.

Calibration Procedure:

- a) Characterise the attenuator (determine A and Z_A).
- b) Set the signal generator to 4.23 MHz and CW.
- c) Adjust the output amplitude so that the current through the Current Sense Balun is approximately 50 mA. With a 20 dB attenuator this corresponds to a Power Meter 2 reading (P_{M2}) of approximately + 1 dBm.
- d) Record the exact reading of Power Meter 1 and Power Meter 2 (P_{1c} should be approximately – 13 dBm with the described design).
- e) Calculate k using equation 2 above (observe separate k -factors for 4.23 MHz and 27.095 MHz).
- f) Repeat steps a through e for the frequency 27.095 MHz.

The attenuation of the attenuator used in the set-up should be approximately 20 dB, and has to be carefully evaluated prior to calibration. The exact attenuation value and the input impedance have to be considered (A and Z_A in the equations above).

In order to maintain the accuracy during the actual measurements, the same Power Meter 1 sensor shall to be used as during the calibration (otherwise the change of impedance might decrease the accuracy).

Finally, it should be observed that this process ensures high accuracy for signals of frequencies in the Up-link and Tele-powering signal bands only.

Annex I Intensionally Deleted

Annex J (Informative), Test Tool for LZB Cable testing

J1 General

The herein described implementations are sufficiently detailed for mandatory On-board testing purposes. Optional Balise testing may require adaptations because the test object is not only the Balise, but also fixation devices, installation rules, and possible RF chokes or similar devices.

J2 Overall Designs

J2.1 General

The various tools used for LZB testing are loops surrounding defined areas. Some tools are tuned in order to be able to provide the required impedance and to achieve uniformly distributed currents. The exception is the horizontal loop used for 4.2 MHz On-board tests. In that case, the current distribution is sufficiently uniform without tuning, and the actual impedance is of less importance (since the actual current is monitored).

J2.2 Vertical Loop used for 4.2 MHz Balise Tests

This tool has to be tuned at 4.24 MHz.

The overall impedance of the tool shall be 75 Ω (provided through adding sufficient resistance after tuning).

This tool shall be designed according to the overall configuration shown in Figure 97. The assembly details shall be made from non-conductive material.

The size of the loop shall be 1200 mm by 500 mm. The tool consists of 2 cable sections of 1200 mm each. The cable sections are inter-connected to the large low impedance vertical segments via PCB's, which are equipped with capacitors and a resistor. For measuring the current, the tool is equipped with a current probe. The recommended type is a Tektronix CT-2 current probe.

The lower cable segment shall be positioned at least 200 mm above any ground structure (e.g., reinforced concrete floors) in order to avoid influence from the environment.

Technical data of the recommended cable forming the 2 cable sections:

Conductive material:	Copper 7 x 0.6 mm \emptyset
PE – Isolation:	Thickness 3.6 mm
PE – sheath:	Thickness 1.7 mm
Outside diameter:	12.4 mm \pm 0.3 mm

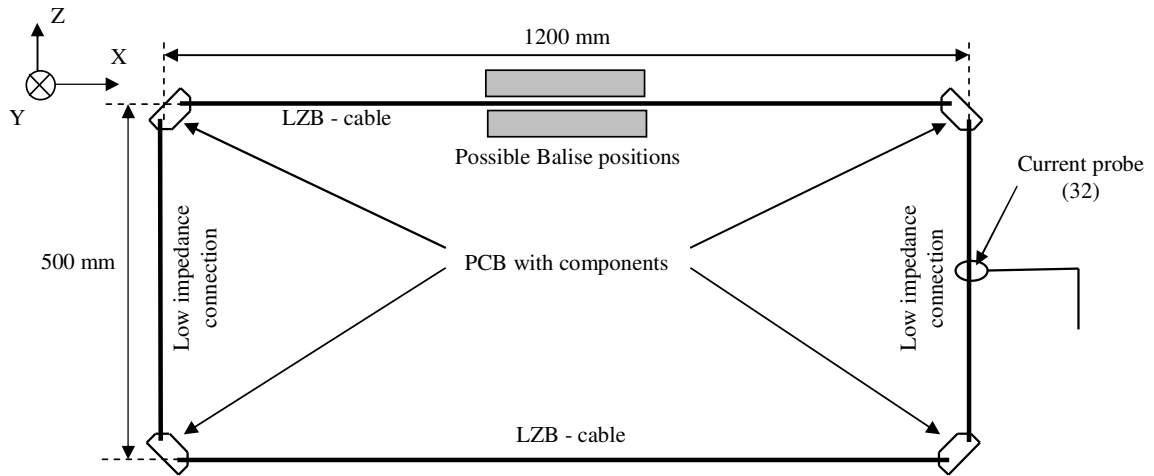

Figure 97: Vertical Loop used for 4.2 MHz Balise Tests

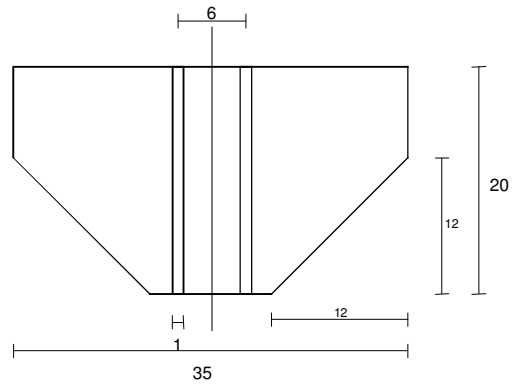

Figure 98: Printed Circuit Board

J2.3 Horizontal Loop used for 4.2 MHz On-board Equipment Tests

This tool is not tuned.

This tool shall be designed according to the overall configuration shown in Figure 99. The assembly plate shall be made from non-conductive material.

The size of the loop shall be 1550 mm by 520 mm. The tool consists of one single piece of LZB loop cable. For measuring the current, the tool is equipped with a current probe. The recommended type is a Tektronix CT-2 current probe.

The tool is equipped with an internal Balun. The recommended type is 0010 from North Hills Signal Processing (50 Ω balanced to 50 Ω unbalanced Balun Transformer).

Technical data of the recommended cable forming the cable segment:

Conductive material:	Copper 7 x 0.6 mm \varnothing
PE – Isolation:	Thickness 3.6 mm
PE – sheath:	Thickness 1.7 mm
Outside diameter:	12.4 mm \pm 0.3 mm

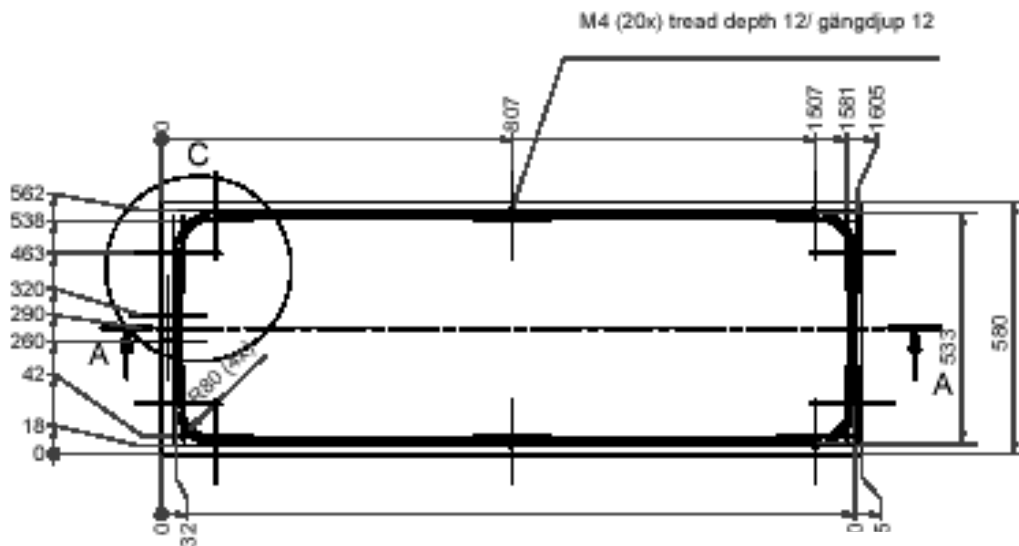

Figure 99 Horizontal Loop used for 4.2 MHz On-board Equipment Tests

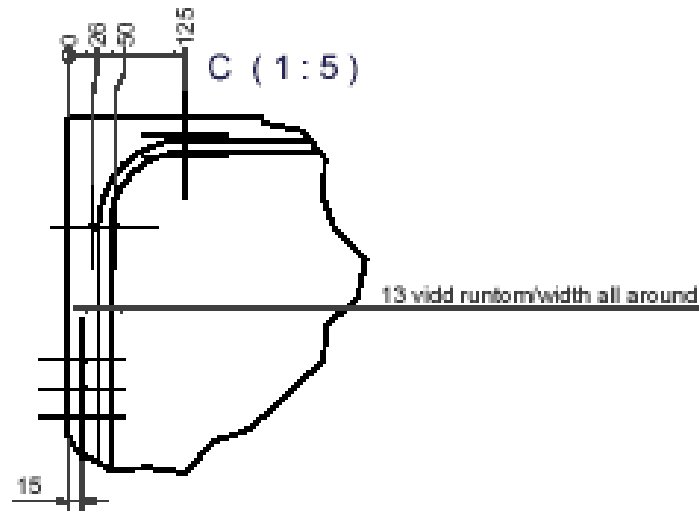

Figure 100 Horizontal Loop, detail C

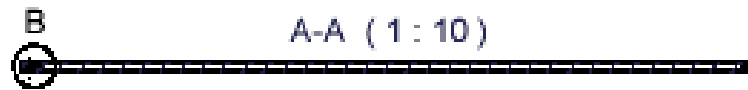

Figure 101 Horizontal Loop, cut A-A

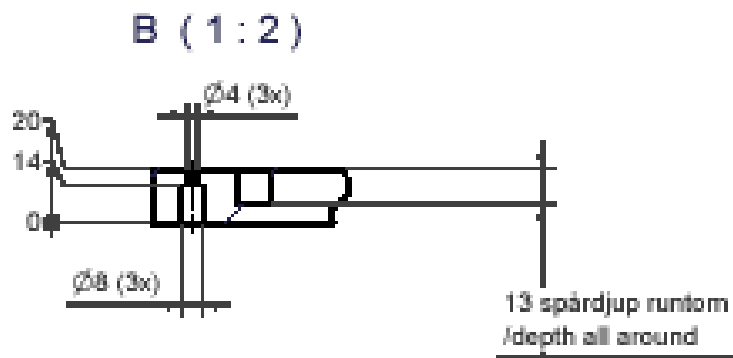

Figure 102 Horizontal Loop, detail B

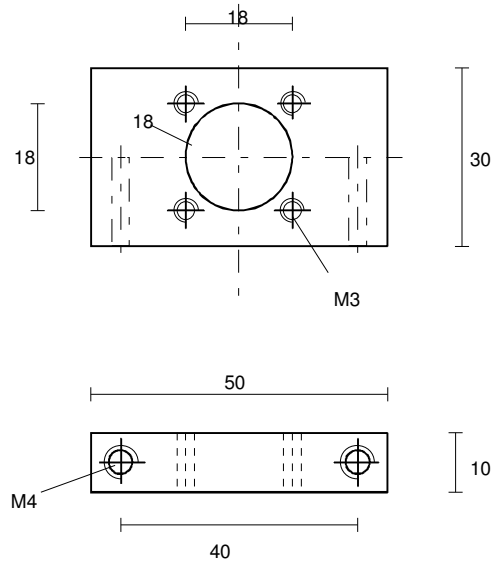

Figure 103: N-Connector support

J2.4 Vertical Loop used for 27 MHz Tests

This tool has to be tuned at 27.095 MHz. Please observe that the tuning needs to be performed with the applicable balun connected to the loop. However, the balun is not part of the tool itself. Therefore, the network analyser calibration (open, short and 50 Ω) shall be performed with the balun.

The overall impedance of the tool shall be 75 Ω (provided through adding sufficient resistance after tuning).

This tool shall be designed according to the overall configuration shown in Figure 104. The assembly details shall be made from non-conductive material.

The size of the loop shall be 1200 mm by 500 mm. The tool consists of several cable sections of lengths as defined in Figure 104. The cable sections are inter-connected via PCB's (see Figure 105), which are equipped with capacitors and a resistor. For measuring the current, the tool is equipped with a current probe. The recommended type is a Tektronix CT-2 current probe.

The lower cable segment shall be positioned at least 200 mm above any ground structure (e.g., reinforced concrete floors) in order to avoid influence from the environment.

Technical data of the recommended cable forming the cable sections:

Conductive material:	Copper 7 x 0.6 mm \varnothing
PE – Isolation:	Thickness 3.6 mm
PE – sheath:	Thickness 1.7 mm
Outside diameter:	12.4 mm \pm 0.3 mm

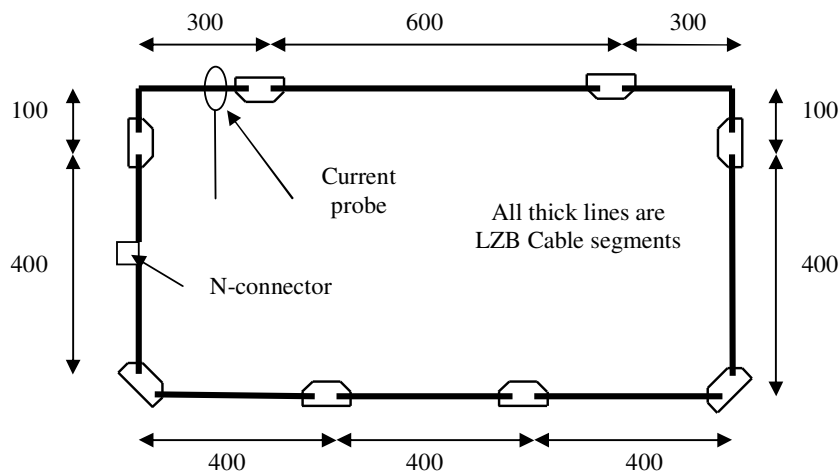

Figure 104: Vertical Loop used for 27 MHz Tests

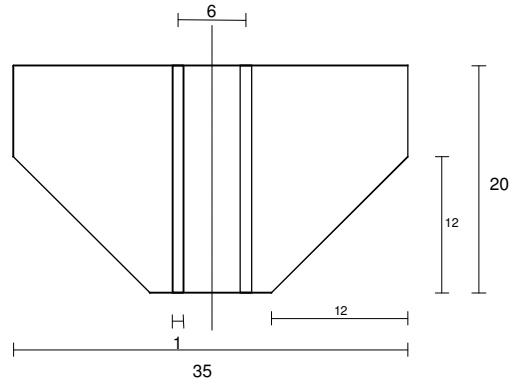

Figure 105: Printed Circuit Board

J3 Printed Circuit Board and Components

The cable sections are inter-connected via printed circuit boards. Each PCB is equipped with capacitors and a resistor.

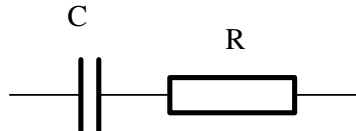

Figure 106: Printed Circuit Board components

The components shown in Figure 106 shall be stable with respect to temperature variations and ageing.

Considering experience, the following guidelines apply:

- For the tool of sub-clause J2.2 on page 333, C should be a parallel combination of capacitors providing approximately 1.33 nF (to be precisely determined during the tuning process) for each PCB. For the tool of sub-clause J2.4 on page 338, C should be a parallel combination of capacitors providing approximately 60 pF (to be precisely determined during the tuning process) for each PCB.
- R shall be added such that the total loop impedance is 75 Ω for the loop described in sub-clause J2.2, and 75 Ω for the loop described in sub-clause J2.4 (suitably split between all the PCB's in both cases). Please observe that high power may apply to the loop described in sub-clause J2.4, and that inductance “free” resistors shall be used.

J4 Tuning of the LZB Loop

As part of the manufacturing process, the loops described in sub-clauses J2.2 on page 333 and J2.4 on page 338 have to be electrically tuned. Please observe that tuning of the loop described in sub-clause J2.4 shall be performed with the applicable balun connected to the loop. However, the balun is not part of the tool itself. Therefore, the network analyser calibration (open, short and $50\ \Omega$) shall be performed with the balun.

The following procedure shall be used. An acceptably tuned tool shall provide a value of the imaginary part of the reactance that is less than one tenth of the overall target impedance (at 4.24 MHz and 27.095 MHz respectively).

1. For the tool of sub-clause J2.2, connect capacitors such that 1.33 nF is obtained on each PCB, and short circuit all resistors. For the tool of sub-clause J2.4, connect capacitors such that 60 pF is obtained on each PCB, and short circuit all resistors.
2. Measure the actual impedance at 4.24 MHz (for the tool of sub-clause J2.2) or at 27.095 MHz (for the tool of sub-clause J2.4) with all the capacitors mounted on the PCB's. If the value of the imaginary part of the reactance is not less than one tenth of the target impedance, then C has to be adjusted accordingly.
3. Add one or several resistors at each PCB such that the overall impedance is $75\ \Omega$ for the loop described in sub-clause J2.2, and $75\ \Omega$ for the loop described in sub-clause J2.4. The total resistance should be as evenly spread as possible between the four PCB's.