

ERTMS/ETCS

Interface 'K' Specification

REF : SUBSET-101

ISSUE : 2.0.0

DATE : February 24, 2012

Company	Technical Approval	Management approval
ALSTOM		
ANSALDO		
BOMBARDIER		
INVENSYS		
SIEMENS		
THALES		

MODIFICATION HISTORY

Issue Number Date	Section Number	Modification / Description	Author
0.0.1, 2004-02-16		Initial draft based on meeting discussions.	B. Sjöbergh
0.0.2, 2004-02-25		Update including Bombardier suggestions for improvements.	P. Lundberg
0.0.3, 2004-03-19		Update considering conclusions from the fourth WGKI meeting, and Bombardier suggestions for improvements.	P. Lundberg
0.0.4, 2004-05-06		Update considering conclusions from the fifth WGKI meeting, and Bombardier suggestions for improvements.	P. Lundberg
0.0.5, 2004-08-09		Update considering discussions from the seventh WGKI meeting, and Bombardier suggestions for improvements.	P. Lundberg
0.0.6, 2004-10-04		Update considering Bombardier suggestions for improvements.	P. Lundberg
0.0.7, 2004-10-19		Update considering discussions during the ninth WGKI meeting.	P. Lundberg
0.0.8, 2004-10-29		Update considering discussions during the tenth WGKI meeting.	P. Lundberg
0.0.9, 2004-12-03		Update considering discussions during the eleventh WGKI meeting.	P. Lundberg
0.0.10, 2005-01-17		Update considering discussions during the twelfth WGKI meeting.	P. Lundberg
0.0.11, 2005-02-17		Update considering discussions during the thirteenth WGKI meeting.	P. Lundberg
0.0.12, 2005-02-25		Update considering e-mail discussions.	P. Lundberg
0.1.0, 2005-03-09		First official draft.	P. Lundberg
0.1.1, 2005-05-13		Update considering conclusions from the fifteenth and sixteenth WGKI meetings.	P. Lundberg

Issue Number Date	Section Num- ber	Modification / Description	Author
0.1.2, 2005-06-15		Final working draft.	P. Lundberg
0.2.0, 2005-06-23		Second official draft.	P. Lundberg
0.2.1, 2005-09-01	3.1.1, 4.1.1.3.1, 4.1.1.3.2	Update considering conclusions from the eighteenth WGKI meeting.	P. Lundberg
1.0.0, 2005-10-04		Final update (only change of issue status).	P. Lundberg
1.0.1, 2006-04-27	3.1.2, 3.1.4	Clarifications to CRC generation.	P. Lundberg
1.0.2 2012-02-20	3.1.2, 3.1.4, 3.1.6, 4.1.2.7	Updated in accordance with CR 1049 and CR 1052.	P. Lundberg
2.0.0 2012-02-24		Baseline 3 release version (only change of Issue number).	P. Lundberg

Foreword

This document is the specification for the Interface 'K' between the ERTMS/ETCS On-board BTM functionality and the KER STM's.

The purpose of Interface 'K' is to make it possible to have a common Balise antenna used by ERTMS/ETCS On-board Equipment as well as by one or several KER STM's.

Contents

1	GENERAL	7
1.1	Introduction	7
1.2	Scope	8
1.3	Functional Description	9
1.4	Alternative Interfaces	9
2	TERMINOLOGY	10
2.1	Abbreviations	10
2.2	Acronyms	10
2.3	Definitions	11
3	PHYSICAL TRANSMISSION	13
3.1	Alternative 1	13
3.1.1	Architecture	13
3.1.2	Functional Data	15
3.1.3	Electrical Data	18
3.1.4	Data Transmission	18
3.1.5	Timing Requirements	20
3.1.6	Procedural Requirements	20
3.1.7	Handling of Safety Diversified Data	22
3.2	Alternative 2	23
3.2.1	Architecture	23
3.2.2	Functional Data	23
3.2.3	Electrical Data	23
3.2.4	Data Transmission	23
3.2.5	Timing Requirements	24
3.2.6	Procedural Requirements	25
3.2.7	Handling of Safety Diversified Data	25
4	FUNCTIONAL REQUIREMENTS	26
4.1	Alternative 1	26
4.1.1	STM Functionality	26
4.1.2	ERTMS/ETCS Functionality	35
4.1.3	Odometer Requirements for Side Lobe Handling	41
4.1.4	Balise Separation	41
4.1.5	Balise Group Separation	41

4.2	Alternative 2	42
4.2.1	STM Functionality	42
4.2.2	ERTMS/ETCS Functionality	45
4.2.3	Odometer Requirements for Side Lobe Handling	48
4.2.4	Balise Separation	48
4.2.5	Balise Group Separation	48
5	RAMS REQUIREMENTS	49
5.1	Transmission System Aspects	49
5.2	Balise Aspects	49
5.3	On-board Transmission Equipment and STM Aspects	49
5.3.1	General	49
5.3.2	Safety Integrity Requirements related to Interface 'K'	50
6	REFERENCES	52
ANNEX A, ON-BOARD TYPE 1 SPECIFICS		53
A1	GENERAL	53
A2	SAFETY INTEGRITY REQUIREMENTS	53
A3	MAXIMUM NUMBER OF CONSECUTIVE 'ONES'	53
ANNEX B, ON-BOARD TYPE 2 SPECIFICS		54
B1	GENERAL	54
B2	SAFETY INTEGRITY REQUIREMENTS	54
B3	MAXIMUM NUMBER OF CONSECUTIVE 'ONES'	54
ANNEX C, ON-BOARD TYPE 3 SPECIFICS		55
C1	GENERAL	55
C2	SAFETY INTEGRITY REQUIREMENTS	55
C3	MAXIMUM NUMBER OF CONSECUTIVE 'ONES'	55
ANNEX D, ON-BOARD TYPE 4 SPECIFICS		56
D1	GENERAL	56
D2	SAFETY INTEGRITY REQUIREMENTS	56
D3	MAXIMUM NUMBER OF CONSECUTIVE 'ONES'	56

1 General

1.1 Introduction

This document defines an interface between the ERTMS/ETCS On-board BTM function and the KER STM's in order to allow for a common Balise antenna to be used by ERTMS/ETCS On-board Equipment as well as by one or several KER STM's. This interface is called Interface 'K'.

The Eurobalise Transmission System is a safe spot transmission based system conveying safety related information between the wayside infrastructure and the train, and vice-versa. Several countries use an older generation of Balises, as a group known as KER Balises. These are similar enough to make it possible to read both Eurobalises and KER Balises with the same On-board BTM function and antenna unit if the BTM function and antenna are properly adapted. The combination of the antenna and the BTM function is hereafter denominated "On-board Transmission Equipment".

The overall architecture of the ERTMS/ETCS On-board Constituent and the KER STM's regarding the Interface 'G' and the Interface 'K' is shown in Figure 1.

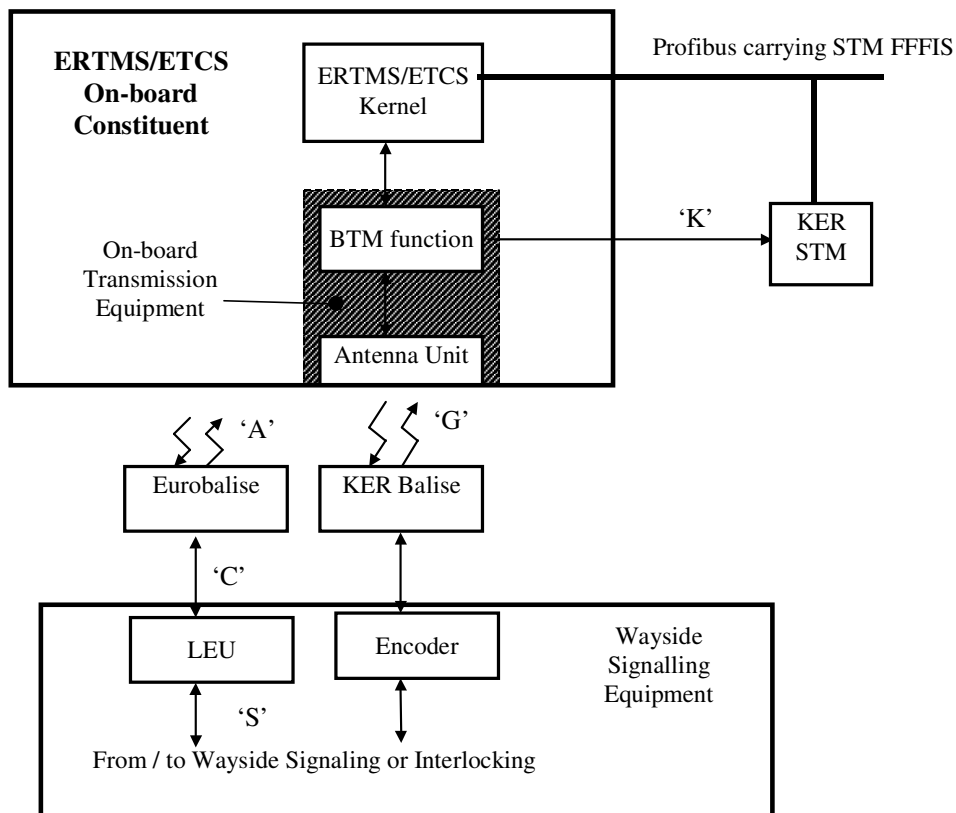

Figure 1: Overall Architecture

Interface 'K' is a one-way communication interface from the On-board Transmission Equipment to the STM's. It is intended for data transfer from KER Balises through the ERTMS/ETCS antenna and BTM function to the STM. This allows the use of common equipment and avoids the duplication of antennas etceteras when using KER STM's. This not only saves the cost of equipment and installation, but also significantly simplifies the installation on vehicles. The constraints on antenna installation makes it difficult and on some vehicles almost impossible to mount multiple antennas. Note that some vehicles require two Eurobalise antennas for bi-directional running. If separate KER antennas were also to be mounted, this would imply four antennas on one vehicle.

Interface 'K' is optional (i.e., BTM functions do not have to be equipped with Interface 'K'). Using a KER dedicated antenna would allow for an installation of a KER STM on a train with an already existing ERTMS/ETCS On-board Equipment without Interface 'K', or in case the ERTMS/ETCS On-board Equipment does not support Interface 'K', or in case the specific national requirements are not fulfilled. A KER STM includes a KER dedicated antenna in its basic concept, and optionally an ERTMS/ETCS antenna utilising Interface 'K'.

The intent of Interface 'K' is to emulate the existing system transmission channels such that the STM can perform the same task as the existing systems when using the Eurobalise On-board Transmission Equipment (suitably adapted).

The Interface 'K' supports the transmission supervision required by some existing KER systems.

1.2 Scope

The purpose of this document is to define the characteristics and the performance of the interface regarding:

- The physical characteristics of the signals.
- The logical system properties of the data.
- The interdependence between the data.
- If the data is mandatory or optional, and if optional on which side of the interface it is so (it can only be optional on one side, it must be mandatory on the other).

1.3 Functional Description

The ASK Balise Transmission Systems are safe, spot transmission based systems that use Balises as a means for transmission. These systems convey safety-related data between the wayside infrastructure and the train.

The transmission of data between the wayside signalling equipment and the On-board Transmission Equipment (Interface 'G' according to Ref. [4]) uses magnetic coupling in the air gap.

The On-board antenna unit emits a magnetic field for Tele-powering of the Balise. The carrier is amplitude modulated with a 50 kHz synchronisation signal, called "non-toggling" 50 kHz modulation. Non-toggling modulation is defined in the Interface 'G' specification, UNISIG SUBSET-100. See Ref. [4].

When the antenna unit is in the contact volume, energy is induced in the Balise reception loop. The Balise responds by sending an amplitude shift keyed (ASK) signal using a carrier frequency of approximately 4.5 MHz. The amplitude of the pulse is decreasing exponentially during the pulse. The data rate from the Balise is 50 kbit/s, which is synchronised with the 50 kHz modulation of the magnetic field from the antenna.

An On-board Transmission Equipment that operates in interoperable mode¹ transmits a 50 kHz synchronisation signal that is pulse width modulated onto the 27.095 MHz carrier frequency (called "toggling" 50 kHz modulation), to which the Eurobalise and the KER Balise shall respond by sending their telegram. Toggling modulation is defined in the Interface 'G' specification (see Ref. [4], UNISIG SUBSET-100).

A Eurobalise On-board Transmission Equipment that operates in basic ERTMS/ETCS mode transmits a continuous wave carrier (27.095 MHz), to which the KER Balises do not respond.

1.4 Alternative Interfaces

For the purpose of Interface 'K', two different alternatives are possible. The first alternative, hereafter referred to as "alternative 1", constitutes a multiplexed concept including transmission of a wide variety of data that support for instance side lobe management in the STM, enhanced link supervision, and possibility to cope with larger dynamic range in the antenna/BTM functionality. The second alternative, hereafter referred to as "alternative 2", is a simplified concept where only the actual bit pattern and a clock signal is transmitted. Alternative 2 implies additional constraints on the Antenna/BTM functionalities in the sense that:

- ERTMS has the full responsibility for selection of antennas (there will no possibility to double check in the STM).
- It is a safety requirement on ERTMS to guarantee that the proper BTM is active on the interface if multiple BTM's are connected to the same bus.
- The properties of the old KER antennas must be implemented in ERTMS.
- The new situation (combination of ERTMS antennas and KER Balises) increases the dynamic range problems.

It is up to the manufacturer of the specific ERTMS/ETCS Antenna/BTM functionality to select either of the two alternatives considering the constraints above.

However, it shall be observed that it is mandatory for the STM manufacturer to implement and support both alternatives.

Chapters herein not having a split between alternative 1 and alternative 2 apply in their entirety to both alternatives.

¹ Interoperable mode means transmitting toggling Tele-powering, which activates both KER Balises and Eurobalises.

2 Terminology

2.1 Abbreviations

The following common abbreviations are used.

Abbreviation	Definition
h	hour
Hz	Hertz
m	meter
Ref.	Reference
s	second

2.2 Acronyms

In general, the acronyms of UNISIG SUBSET-023 (Ref. [6]) apply. Additionally, the following list of acronyms applies within this specification (whereof some are taken from Ref. [1], UNISIG SUBSET-036):

Acronym	Description
ASK	Amplitude Shift Keying
BPL	Bi Phase Level
CS	Cold Standby State (STM state as defined in Ref. [2])
CW	Continuous Wave
DA	Data Available State (STM state as defined in Ref. [2])
FA	Failure State (STM state as defined in Ref. [2])
HS	Hot Standby State (STM state as defined in Ref. [2])
KER	KVB, Ebicab, RSDD
PO	Power On State (STM state as defined in Ref. [2])
S	Used for indicating a paragraph that states a safety requirement

2.3 Definitions

In general, the definitions of UNISIG SUBSET-023 (Ref. [6]) apply. Additionally, the following list of definitions applies within this specification (whereof some are taken from Ref. [1], UNISIG SUBSET-036):

Term	Definition
Antenna Unit	The On-board spot transmission unit, with the main functions to transmit signals to and/or receive signals from the Balise through the air gap.
Balise	A wayside transmission unit that uses the Magnetic Transponder Technology. Its main function is to transmit and/or receive signals through the air gap. The Balise is a single device mounted on the track, which communicates with a train passing over it.
Balise Group	One or several Balises that on a higher system level together create a quantity of information related to the location reference in the track, the direction of validity of data, and train protection information. This is the location in the track where spot transmission occurs.
Balise Transmission Module (BTM)	An On-board module that processes Up-link signals and telegrams. It interfaces the On-board ERTMS/ETCS Kernel and the antenna unit.
Contact Distance	The distance that is needed to ensure transmission from the Balise with the specified quality. The contact distance is dependent on the specific lateral displacement and mounting height.
Contact Length	The contact length of a lobe is the distance between the beginning and the end of the lobe as defined by the lobe begin and the lobe end criteria. The contact length of a Balise is the distance between the first lobe begin and the last lobe end of a certain Balise.
Contact Volume	The volume constituted by the contact distances for all lateral displacements and mounting heights of the antenna where transmission from the Balise is guaranteed with the specified quality.
Cross-talk	When a telegram is read from a Balise that should not be read, e.g., a Balise on another track.
Encoder	Wayside equipment for KER systems reading signal aspect or route information, and translating this to information such that the KER Balise can transmit the corresponding KER telegram to a passing train.
Eurobalise	A Eurobalise is a Balise that fulfils Ref. [1].
Interface 'G'	This is the functional air gap interface between the wayside ASK Balise and the On-board Transmission Equipment
Interoperability	Interoperability between two systems means that they can operate mutually at a specified time and place as to the specified function.
Lobe	Spatial envelope of signal strength received from a Balise.
Magnetic Transponder Technology	A method that uses magnetic coupling in the air gap between a transmitter and a receiver for conveying data. In the transmission system context, it considers systems using the 27 MHz band for Tele-powering and the 4.5 MHz band for Up-link transmission. The magnetic field is mainly vertical, and the transponder is located in the centre of the track.

Term	Definition
Non-toggling signal	50 kHz modulation of the Tele-powering signal, where each modulation pulse has the same length. Characteristic of the modulation used in the older KER ATP systems. A compatible Eurobalise shall be silent when receiving a Tele-powering signal with this type of modulation.
On-board ATP	Consists of an On-board computer, driver's interfaces and train interface functions. It communicates with the On-board Transmission System.
On-board Transmission Equipment	Consists of antenna unit(s) (for Magnetic Transponder Technology), and BTM function(s). It functionally matches the air gap interface and the On-board ERTMS/ETCS Kernel.
Safety	Freedom from unacceptable levels of risk.
Safety Critical	Carries direct responsibility for safety.
Shall	The word implies a mandatory requirement.
Should	The word implies a highly desirable requirement.
Specific Transmission Module (STM)	An On-board module that processes Up-link signals and telegrams used by a specific ATP system.
Telegram	A telegram contains an identified and coherent set of information. There are several types of telegrams related to the existing KER systems.
Tele-powering	The method used for powering a Balise from an antenna unit through the air gap.
Tele-powering signal	A signal transmitted by the On-board Transmission Equipment that activates the Balise upon passage.
Toggling Tele-powering Signal	50 kHz modulation of the Tele-powering signal, where every other modulation pulse is longer. Characteristic of the modulation used in a BTM in interoperable mode. A compatible Eurobalise shall answer with a normal FSK signal when receiving a Tele-powering signal with this type of modulation.
Up-link	All functions that are needed in the transmission system to constitute the communication from the signal matching function to the On-board ATP bus.
Up-link Telegram	This is a telegram used for Up-link communication.
Valid Telegram	Balise telegram containing correctly checked information received from the Balise.

3 Physical Transmission

3.1 Alternative 1

3.1.1 Architecture

Several alternatives are possible as defined below. In the following configurations, it is mandatory for the BTM to provide data via channel a, but channels b, c, and d, are optional. However it is mandatory for the STM to be able to handle all of the a, b, c, and d channels.

The purpose of the channels differs between the various architectures defined below. The a/b channel concept is used for enhanced safety (diversified channels). The a/b/c channel concept is used for enhanced availability (enabling “two out of three” redundancy). Finally, enhanced safety and availability is combined in the a/b/c/d concept, where the a/b channels form a diversified pair and the c/d channels also form a diversified pair. For enhanced availability, either of the two pairs may be selected. Regarding diversified data, see section 3.1.7 on page 22. There is also a need for configuration data. See section 4.1.1.15 on page 34.

In its basic concept, the data to be transferred via Interface ‘K’ is multiplexed onto one single serial channel. See principles in Figure 2 below.

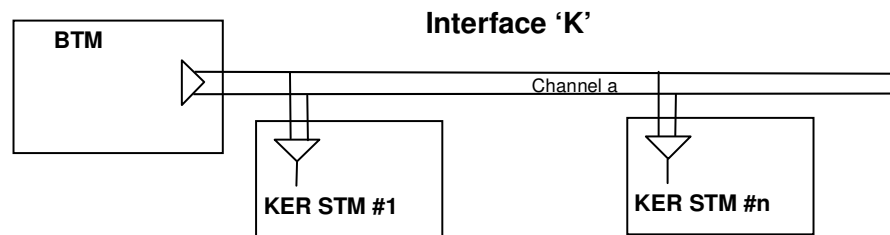

Figure 2: Interface ‘K’, Basic Concept

However, some applications require diversified data for safety reasons. In this case, two independent serial channels transmit a/b diversified data from the BTM function to the STM. See principles in Figure 3 below.

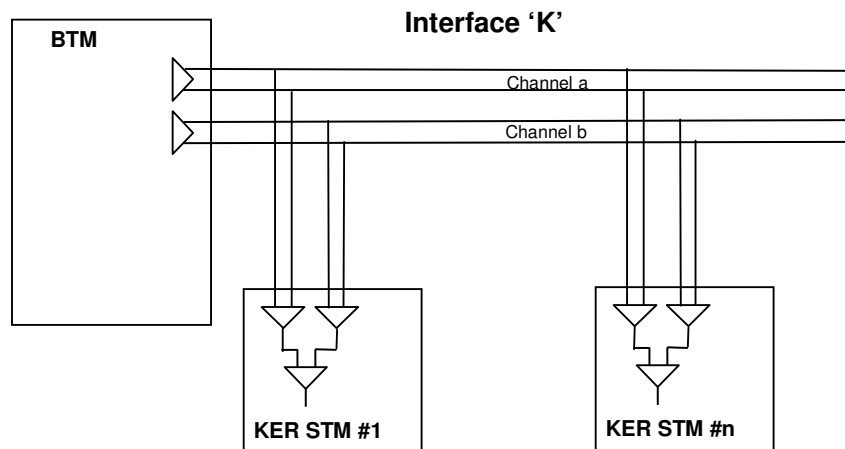

Figure 3: Interface ‘K’ with diversity

In some applications there is a need for redundancy due to availability reasons. In this case three redundant serial channels transmit data from the BTM function to the STM facilitating “two out of three” redundancy (using a/b/c data). See principles in Figure 4 below.

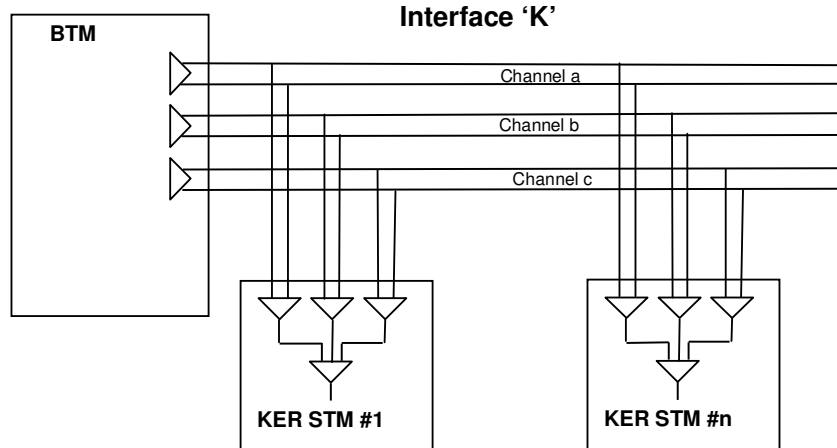

Figure 4: Interface 'K' with “two out of three” redundancy

There are also applications where there is a need for combining diversity due to safety reasons, and redundancy due to availability reasons. In this case four serial channels provide a/b and c/d data. For safety reasons the a/b channels are independent and transmit diversified data. For the same reason the c/d channels are independent and transmit diversified data. Redundancy is achieved by means of having the possibility to select either a/b or c/d channels. See principles in Figure 5 below.

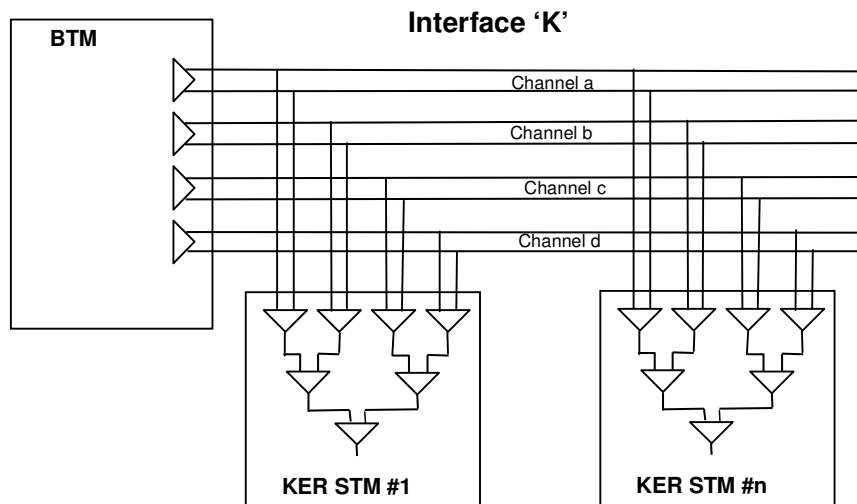

Figure 5: Interface 'K' with combined diversity and redundancy

In case there are redundant BTM's, all these are connected to the same channel(s), but only one of the redundant BTM's shall be active at a time (the others shall provide complete absence of link activity on the Interface 'K').

The BTM shall also for test purposes provide a 50 kHz clock output related to the Tele-powering modulation in the air-gap.

3.1.2 Functional Data

The Interface ‘K’ consists of data generated by the BTM function, multiplexed onto the same serial channel. The data to be transmitted each 20 μ s is defined in Table 1 below. Please observe the aspects regarding polarity, and the aspects on counters, when diversified channels are implemented, as defined in section 3.1.7 on page 22.

Data	Abbreviation/ No. of bits	Description
Data for Balise Detection	BD 1	This data contains the vital detected bit stream of data received by the BTM function via the antenna. This data shall be detected using a fix threshold in the BTM function. A “zero” in the air-gap (energy) is indicated with logical ‘zero’ BD data, and a “one” in the air-gap (no energy) is indicated with logical ‘one’ BD data.
Data for Telegram Decoding	TD 1	This data contains the optimally detected data. This data may be detected using a dynamic threshold in the BTM function. Optimal data shall not be decoded more than 4 dB below the fix data threshold, and always above the fix data threshold. A “zero” in the air-gap (energy) is indicated with logical ‘zero’ TD data, and a “one” in the air-gap (no energy) is indicated with logical ‘one’ TD data.
ERTMS Unavailability	EU 1	This data indicates if the BD data is not reliable due to that vital Balise Detection is temporarily not guaranteed. ERTMS Unavailability is indicated with logical ‘one’ EU data, and available functionality is indicated with logical ‘zero’ EU data.
Eurobalise Reception	EB 1	This data indicates if the BD data is caused by a Eurobalise passage is in progress. It must be set according to definitions in section 4.1.2.6 on page 39, such that the STM can invalidate the Balise and not erroneously report it. Eurobalise reception is indicated with logical ‘one’ EB data, and no reception is indicated with logical ‘zero’ EB data. All ‘zero’ BD data is transmitted during Eurobalise reception.
Link Test Data	LT 1	This data indicates if a link test is in progress. Progressing test is indicated with a logical ‘one’ LT data, and no test in progress is indicated with logical ‘zero’ LT data.
Signal Strength Data	S 4	This data reflects the Up-link signal strength in the BTM ASK receiver. This may aid the STM in side-lobe suppression. If all bits are set to logical ‘zero’ it indicates that no S data is available from the BTM function. All bits set to logical ‘one’ indicate the strongest Up-link signal level. S ₁ is the least significant bit (LSB) and S ₄ is the most significant bit (MSB). LSB set to logical ‘one’ and remaining bits set logical ‘zero’ indicate the lowest Up-link signal level. S data should be such that it is always possible to distinguish between the main lobe and a potential side lobe. The actual choice of implementation is manufacturer dependent as long as the main lobe is always indicated as being stronger than a side lobe. Saturation in the main lobe is not a problem as long as it is handled properly with respect to the strongest possible side lobe. The STM shall sample S data at least each 16 ASK bit.

Data	Abbreviation/ No. of bits	Description
Antenna/BTM ID Data	A 2	This data reflects from which antenna/BTM function all information is transmitted. <ul style="list-style-type: none"> • $A_1 = 0$ and $A_2 = 0$ means Antenna 1 • $A_1 = 1$ and $A_2 = 0$ means Antenna 2 • $A_1 = 0$ and $A_2 = 1$ means Antenna 3 • $A_1 = 1$ and $A_2 = 1$ means Antenna 4
Link ID Data	L 2	This data reflects via which channel the information is transmitted. <ul style="list-style-type: none"> • $L_1 = 0$ and $L_2 = 0$ means Channel a • $L_1 = 1$ and $L_2 = 0$ means Channel b • $L_1 = 0$ and $L_2 = 1$ means Channel c • $L_1 = 1$ and $L_2 = 1$ means Channel d
Bit Counter	B 3	This constitute a 3 bit wrap around counter that is incremented with one each time the information from one ASK bit is transmitted. B_1 is the least significant bit (LSB) and B_3 is the most significant bit (MSB).
Start Bit	STA 1	This data defines the start of each transmission (each 20 μ s). The start bit is represented by logical 'zero'.
CRC	C 8	This is the CRC sum calculated over all information in the actual transmission, including the CRC, but excluding the start bit and the stop bits. The integrity is characterised by the following generator polynomial: $1+x+x^3+x^4+x^7+x^8$ The MSB of the CRC shall be shifted in/out first. For the purpose of initialisation of the 8 bit shift register for the generator polynomial, all zeros shall be used.
Stop Bits	STO 25	This data defines the end of each transmission (each 20 μ s). The stop bits are represented by logical 'ones'. The number of stop bits shall be such that the continuous stream of high level bits is equal to or more than 10 μ s. ²

Table 1: Description of Data

² The defined number of bits is the nominal value. However, due to the need for making it possible to synchronise in case there is a clock drift, the transmitter may insert one extra bit or delete one bit in order to maintain synchronism with 50 kbit/s data rate from the air gap. See also section 3.1.5 on page 18.

The individual data defined in Table 1 above is in general mandatory, but in some cases it is allowed that certain BTM functions do not explicitly generate the data. This is defined in Table 2 below.

Data	BTM function	STM
BD	Mandatory	Mandatory
TD	Mandatory If specific TD data is not provided, then the data field shall be set identical to the BD data.	Mandatory
EU	Mandatory	Mandatory
EB	Mandatory	Mandatory
LT	Mandatory	Mandatory
S	Mandatory All bits shall be set to zero to indicate if no S data is available from the BTM function.	Mandatory
A	Mandatory	Mandatory
L	Mandatory	Mandatory
B	Mandatory	Mandatory
STA	Mandatory	Mandatory
C	Mandatory	Mandatory
STO	Mandatory	Mandatory

Table 2: Mandatory versus Optional Data

3.1.3 Electrical Data

There is an allowance for external adapters in both the BTM side and the STM side of the interface.

The serial channel(s) shall comply with the RS 485 standard (see Ref. [7]).

There shall be a maximum of four originators (redundant physical BTM functions) and 8 redundant receiver STM's.

The electrical specification applies to the output of the transmitter side (BTM function), considering the worst case load condition allowed by the RS 485 standard.

The termination specified by the RS 485 standard is an installation issue, but each installation shall fulfil the RS 485 standard. However, it is mandatory to respect also the recommendations given in the RS 485 standard.

The default STM configuration shall be without any RS 485 termination.

All STM's are connected in parallel to these channels. If redundant physical BTM functions or BTM functions from each end of the train are used, only one at a time shall drive the data lines. The responsibility for this lies with the BTM function and the ERTMS/ETCS, not the STM or the Interface 'K'.

The electrical isolation requirements defined by Ref. [5], EN 50155, shall be fulfilled.

3.1.4 Data Transmission

All data for each respective channel shall be transmitted as defined in Figure 6 below.

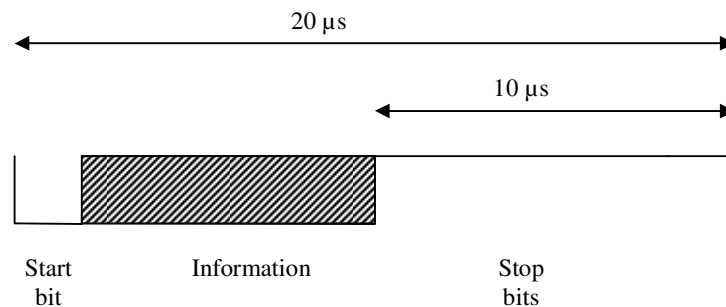

Figure 6: Transmission of Data

The field referred to as "Information" in Figure 6 shall be composed as defined in the example in Figure 7, where also the order in which the data shall be transmitted is defined.

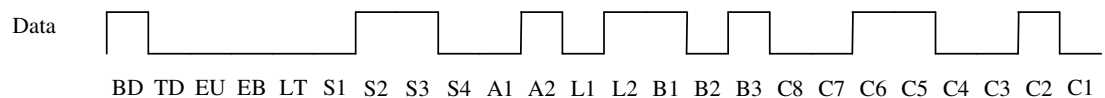

Figure 7: Disposition of Data

The CRC encoding/decoding is clarified in Figure 8 below.

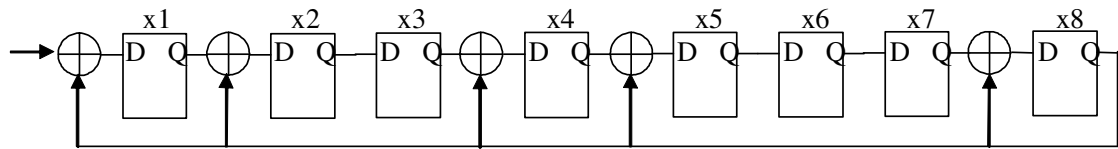
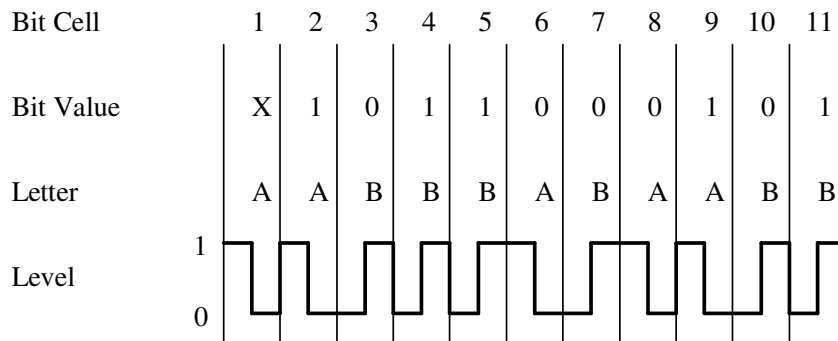

Figure 8: Clarifications to CRC encoding/decoding

During encoding, the 16 data bits shall first be shifted in. Thereafter, eight trailing zeros shall be shifted in, and then the CRC checksum is found in the registers (provided the registers are initialised to zero before the process is started). The MSB of the CRC shall be transmitted first (see Figure 7).

During decoding, the 16 data bits shall first be shifted in, followed by the eight CRC bits (MSB first). Provided the registers are initialised to zero before the process is started, they will include all zeros when the last CRC bit is shifted in.

The signal shall be Bi-Phase-Level (BPL) coded according to Figure 9. This coding applies to all transmitted bits including the start bit and the stop bits. Please observe that this additional coding is not indicated in Figure 7.



'X' = Don't know

Figure 9: Differential Bi-Phase-Level coding scheme

This means that the determination of the bit value is performed in two stages. The first stage is to translate the phase shift in the centre of each bit cell into a letter. A shift from 1 to 0 is translated into an 'A', and a shift from 0 to 1 is translated into a 'B'. The second stage is to compare the current letter with the previous one. If they are equal, the current bit value is a '1'. If they are not equal, the value is a '0'.

Data shall be evaluated by the STM using the positive or negative edge in the middle of the data bit of the BPL Coded signal.

3.1.5 Timing Requirements

The phase position between various channels (if more than one is implemented) shall not deviate by more than $\pm 5 \mu\text{s}$ from each other.

The tolerance in data rate at the level defined in section 3.1.4 on page 18 (2.5 Mbit/s) shall be such that the number of stop bits are always in-between 24 and 26 during each 20 μs period.

The maximum propagation delay from the bit detection to the Interface 'K' data output shall be such that the requirement on memorisation is not violated.

The overall response time from information on a signal in stop being available in the air gap until the emergency brake command is issued is KER system specific.³

The maximum jitter in the BPL clock signal of Figure 9 shall be less than $\pm 50 \text{ ns}$.⁴

The maximum allowed jitter in the last stop bit of Figure 6 shall be $\pm 1 \text{ bit}$. See also footnote 2 on page 16.

3.1.6 Procedural Requirements

- S There is a global requirement that the accumulated maximum allowed number of incorrect information bits shall not exceed 10 ASK bits during a period of time corresponding to 100000 ASK bits. This refers to accumulated errors in the data 'Antenna/BTM ID', 'Link ID' 'CRC', and the event that it is not possible to find 24 to 26 stop bits (see also footnote 2 on page 16). If this limit is exceeded, the link shall immediately be considered failed. Please observe that the above does not apply to intentionally erroneous CRC during the link test.
- S Unless it is guaranteed by other means that the intended Antenna/BTM function is selected, the STM shall actively supervise that the information comes from the intended source (using the Antenna/BTM ID data). The STM shall also supervise that data is transmitted via the intended channel(s) (using the Link ID data). In case of irregularities, a manufacturer defined reaction shall occur within a manufacturer defined reaction time that shall not exceed 1 s. Detection time for potential irregularities shall be such that the detection of a Balise Group (two consecutive Balises positioned at shortest allowed distance) is never jeopardised. The specific STM may choose to either use data in ASK bits where irregularities are detected, or not (as long as the global requirement on maximum 10 errors during 100000 bits is not violated). The Antenna/BTM ID data and Link ID data shall only be supervised for ASK bits where the CRC is correct.
- S The STM shall actively supervise that the received data is not Eurobalise data (using the Eurobalise Reception data). In case of irregularities, the STM shall invalidate the data of the Balise if Eurobalise Reception data is set to 'one' for at least 16 consecutive ASK bits. See section 4.1.2.6 on page 39 for further details. Please observe that potential transmission of data indicating Eurobalise data shall not be treated as Eurobalise data in case Link Data indicates that a link test is in progress. In case Eurobalise Reception data is erroneously stuck to logical 'one' for a long time, the STM shall issue a manufacturer defined reaction within a manufacturer defined reaction time that shall not exceed 1 s. Detection time for potential irregularities shall be such that the detection of a Balise Group (two consecutive Balises positioned at shortest allowed distance) is never jeopardised.

³ Currently, the requirement is in the order of 500 ms in Sweden and 300 ms in France.

⁴ This applies from one edge to the next edge in the BPL clock.

- S** The STM shall actively supervise if the ERTMS/ETCS does not guarantee vital Balise detection ability (using the ERTMS Unavailability data).⁵ In case of irregularities, the STM shall issue a manufacturer dependent reaction in accordance with a manufacturer defined reaction criterion. Detection time for potential irregularities shall be such that the detection of a Balise Group (two consecutive Balises positioned at shortest allowed distance) is never jeopardised. The ERTMS Unavailability data shall only be supervised for ASK bits where the CRC is correct.
- S** The STM shall actively supervise if a link test is in progress (using the Link Test Data). In case of irregularities, the STM shall issue a manufacturer defined reaction within a manufacturer defined reaction time that shall not exceed 1 s. Detection time for potential irregularities shall be such that the detection of a Balise Group (two consecutive Balises positioned at shortest allowed distance) is never jeopardised.
- S** The STM shall actively supervise that the transmission is not disturbed (using the CRC). In case of irregularities, a manufacturer defined reaction shall occur within a manufacturer defined reaction time that shall not exceed 1 s. Detection time for potential irregularities shall be such that the detection of a Balise Group (two consecutive Balises positioned at shortest allowed distance) is never jeopardised. For ASK bits where the CRC is corrupt, BD data and TD data shall be used (as long as the global requirement on maximum 10 errors during 100000 bits is not violated).
- S** The STM shall actively supervise that no bit slip or bit insert is introduced in the transmission. This is preferably performed through checking that the 'Bit Counter' is incremented by one each time a new ASK bit is received. In case of irregularities, the STM shall issue a manufacturer defined reaction within a manufacturer defined reaction time that shall not exceed 1 s. Detection of potential irregularities shall occur within a time not exceeding a period of time corresponding to 64 ASK bits.
- S** The STM shall actively supervise that 24 to 26 stop bits are received. In case of irregularities, the STM shall issue a manufacturer defined reaction within a manufacturer defined reaction time that shall not exceed 1 s. Detection time for potential irregularities shall be such that the detection of a Balise Group (two consecutive Balises positioned at shortest allowed distance) is never jeopardised.
- S** A start bit shall only be accepted after the reception of 24 to 26 stop bits.

In order to indicate that a switching of antenna will occur, ERTMS Unavailability Data shall be set concurrently with changing the Antenna/BTM ID Data.

It is mandatory that Interface 'K' is active when toggling mode is selected. When CW mode is selected, the interface 'K' link may be inactive (not even transmitting BPL coding), but it is allowed to also keep the link active. In the latter case, the ERTMS Unavailability Data shall be set, and transmission of information shall be such that the CRC is correct.

No Balise data should be derived from the Interface 'K' by an STM that is not in the states HS or DA.

It is not mandatory for the BTM to have the Interface 'K' link active when:

- None of the cabs are active.
- The BTM is not transmitting toggling Tele-powering (i.e., when the STM is not in DA or HS states).
- There is a permanent failure in the On-board Transmission Equipment.

When the "STM Specific Test Procedure" (see Ref. [2], UNISIG SUBSET-035, section 13.2) is activated, the Interface 'K' shall be active depending on the On-board equipment configuration regarding the applicable STM.

In case there is a problem with the Interface 'K' link when the configuration is such that Interface 'K' is used, it is mandatory that the STM either does not confirm HS (when being ordered to HS), or gives an openly defined manufacturer dependent reaction.

⁵ This also covers the case that Tele-powering is turned off.

3.1.7 Handling of Safety Diversified Data

In case safety diversified data is transmitted for safety reasons, data in the applicable channels shall be compared and evaluated by the STM. The following applies for the purpose of comparing data from the two channels.

Data	Description
BD	'Zeros' shall take precedence (i.e., not a "true compare" but rather an AND function).
TD	Not applicable for the purpose of safety diversity check. The two channels provide true redundancy using the link CRC, the transmission CRC, and the use of the Bit Counter as means to guarantee the integrity.
EU	A "true compare" shall be performed for the purpose of safety diversity check.
EB	'Zeros' shall take precedence (i.e., not a "true compare" but rather an AND function).
LT	A "true compare" shall be performed for the purpose of safety diversity check.
S	In case any channel transmits all four bits equal to zero, this takes precedence.
A	A "true compare" shall be performed for the purpose of safety diversity check.
L	Data shall be verified to comply with each respective intended channel (i.e., no safety diversity check).
B	Regarding B data, the a (or c) channel shall count up incremented by one (modulo 8), and the b (or d) channel shall count down incremented by one (modulo 8) for each ASK bit. Both channels shall be correct.
STA	Not applicable for the purpose of safety diversity check.
C	CRC shall be verified for each channel separately without comparison between channels (i.e., no safety diversity check).
STO	Not applicable for the purpose of safety diversity check.

Table 3: Handling of Safety Diversified Data

In case there is a CRC failure in either channel, there shall not be any check with respect to safety diversity.

The four mandatory ASK bits included in the link test pattern shall be identical for the two channels with respect to BD, TD, EU, EB, LT, and SS data.

For safety diversified channels, data in the b (and/or d) channel shall be inverted with respect to the a (and/or c) channel. This applies to BD, TD, EU, EB, LT, and A data of Table 3 above.

3.2 Alternative 2

3.2.1 Architecture

The overall architecture defined in section 3.1.1 on page 13 applies. However, this alternative 2 is a simplified concept where only the actual bit pattern and a clock signal is transmitted, i.e., each channel is composed of one data link and one clock link.

3.2.2 Functional Data

The BTM shall transmit the ASK data received from KER Balises to the STMs without any treatment or message decoding. The ASK data are, in fact, the raw bit stream of data present at the output of the ASK demodulator.

3.2.3 Electrical Data

See section 3.1.3 on page 18, however, if more than one BTM function is needed, only one shall be connected at a time. The responsibility for this lies with the BTM function and the ERTMS/ETCS, not the STM or the Interface 'K'.

3.2.4 Data Transmission

The interface consists of two signals generated by the BTM:

- Data signal. This signal contains the bit stream of data (at 50 kbits/s) received by the BTM through the antenna.
- CLK Signal. This signal is the clock necessary for the receivers, the STMs, to sample the data signal. The data shall be sampled at the positive edges of this clock signal.

3.2.5 Timing Requirements

The timing of Data and CLK signals is described in Figure 10. The signal Data is valid on the rising edge of the CLK signal. The Data set-up and hold times are 1 μ s minimum.

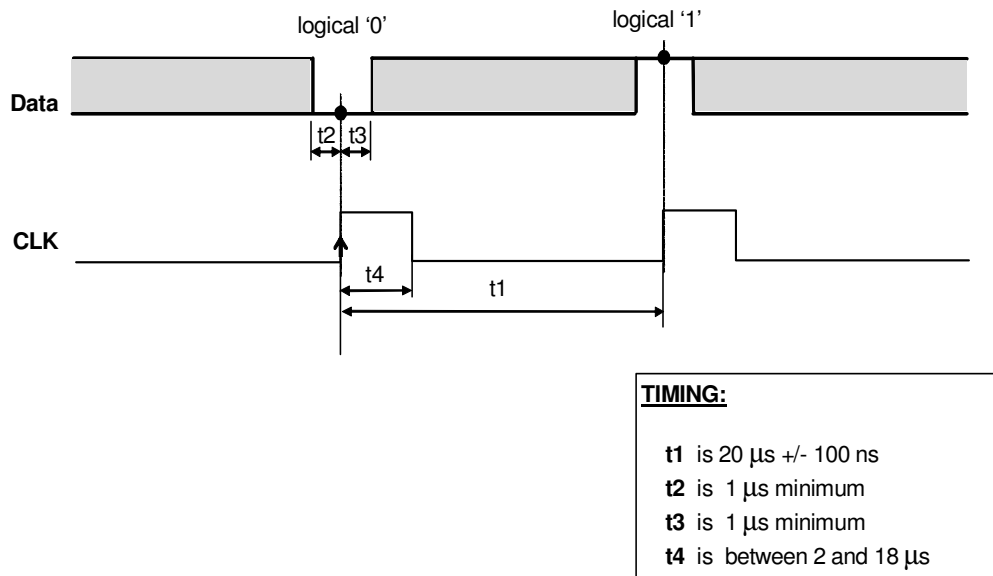

Figure 10: Timing when reading KER Balises

The phase position between various channels (if more than one is implemented) shall not deviate by more than $\pm 5 \mu$ s from each other.

The maximum propagation delay from the bit detection to the Interface 'K' data output shall be such that the requirement on memorisation is not violated.

The overall response time from information on a signal in stop being available in the air gap until the emergency brake command is issued is KER system specific.⁶

⁶ Currently, the requirement is in the order of 500 ms in Sweden and 300 ms in France.

3.2.6 Procedural Requirements

- S** The STM shall actively supervise that the received data is not Eurobalise data. In such a case, the STM shall invalidate the data of the Balise. See section 4.2.2.6 on page 46 for further details. In case Eurobalise reception is permanently indicated, the STM shall issue a manufacturer defined reaction within a manufacturer defined reaction time that shall not exceed 1 s. Detection time for potential irregularities shall be such that the detection of a Balise Group (two consecutive Balises positioned at shortest allowed distance) is never jeopardised.
- S** The STM shall actively supervise if a link test is in progress. In case of irregularities, the STM shall issue a manufacturer defined reaction within a manufacturer defined reaction time that shall not exceed 1 s. Detection time for potential irregularities shall be such that the detection of a Balise Group (two consecutive Balises positioned at shortest allowed distance) is never jeopardised.

It is mandatory that Interface 'K' is active when toggling mode is selected. When CW mode is selected, the interface 'K' link may be inactive, but it is allowed to also keep the link active.

No Balise data should be derived from the Interface 'K' by an STM that is not in the states HS or DA.

It is not mandatory for the BTM to have the Interface 'K' link active when:

- None of the cabs are active.
- The BTM is not transmitting toggling Tele-powering (i.e., when the STM is not in DA or HS states).
- There is a permanent failure in the On-board Transmission Equipment.

When the "STM Specific Test Procedure" (see Ref. [2], UNISIG SUBSET-035, section 13.2) is activated, the Interface 'K' shall be active depending on the On-board equipment configuration regarding the applicable STM.

In case there is a problem with the Interface 'K' link when the configuration is such that Interface 'K' is used, it is mandatory that the STM either does not confirm HS (when being ordered to HS), or gives an openly defined manufacturer dependent reaction.

3.2.7 Handling of Safety Diversified Data

For safety diversified channels, data in the b (and/or d) channel shall be inverted with respect to the a (and/or c) channel.

4 Functional Requirements

4.1 Alternative 1

4.1.1 STM Functionality

4.1.1.1 Overview

Table 4 below defines the functionality of the STM.

STM functionality:
Detection of Balises
Management of side lobe effects
Checking of the Interface 'K' signals
Detection of bit errors
Checking of data with respect to coding requirements
Extraction of User Data
Telegram Filtering
Management of telegram switching
Time and odometer stamping of output data
Support to localisation
Eurobalise suppression
Management of antenna distances
Suppression of data during Interface 'K' and/or transmission tests
Management of various architectures

Table 4: STM functionality

Since the Interface 'K' and its use is tightly related to the Interface 'G' and the system oriented functionality, Table 4 should be read with considerations to the On-board Transmission Equipment functionality defined in Ref. [4] and the ERTMS/ETCS functionality defined in section 4.1.2 on page 35.

4.1.1.2 Detection of Balises

The air-gap interface specification (Ref. [4]) defines levels for ASK modulation for detection of signals from operational Balises within the air-gap tolerances. This shall correspond to the safe detection output, which is the minimum required functionality.

The Data for Balise Detection shall be sent through the interface when the signal level is above the threshold. As the modulation in the Up-link is ASK, the exact start and end of the lobe created by the movement of the train is distorted by the bit pattern of the coded data. It shall be the responsibility of the STM to consider that the impact of this bit pattern might decrease the received contact time for the Balise detect function.

A Balise shall be detected if the physical Balise contact time is larger than what is specified in Ref. [4]. Please observe also the remark related to availability with respect to contact distance for safe Balise Detection in Ref. [4].

The STM shall be aware that the On-board Transmission Equipment may report sporadic unavailability (see section 4.1.2 on page 35, e.g., during redundancy switch-over).

4.1.1.3 Management of Side Lobe Effects

4.1.1.3.1 General

Optimally, the STM should use the lobe where the Antenna unit and the Balise are aligned to each other. This lobe is called the main lobe. Outside this lobe the magnetic flux density through the reference area of the Balise changes direction, and the On-board antenna unit generates one or several side lobes.

If the flux in this side lobe is strong enough to activate the Balise, the Balise may respond with an Up-link signal. Thus, the On-board Transmission Equipment and STM may interpret one Balise as two or several Balises.

If more than one lobe is received from one Balise, the STM shall perform filtering such that only one Balise is seen by the On-board functionality. The general principle herein is to ensure that the information from side lobes and the main lobe is coming from the same Balise, such that no extra Balises are generated.

In this concept, there are three sources of information that should be used for the purpose of determining if lobes belong to one specific Balise, or if they come from different Balises. The information should also be used for determining the appropriate localisation information.

The available information consists of the following signals/data:

1. The telegram contents
2. Odometer information
3. Amplitude information

It should be considered that the number of lobes is not limited to just a few, but can during some circumstances be many due to the behaviour of the Balise, and that a weakest possible main lobe may be weaker than a normal side lobe. However, a side lobe is always weaker than the related main lobe, but the extension of a side lobe can be even longer than the main lobe (but with lower amplitude). It is likely that a significant side lobe include the correct (telegram) information.

If a signal is in stop, the STM shall react on the information regardless of if this is coming from a potential side lobe or a main lobe. The reaction time will then be shorter with the presence of a side lobe. This requires that the STM shall command emergency break (after a necessary delay) when the telegram is received, but before the Balise ends. Thus, immediate action shall be taken on restrictive aspect messages regardless of lobe and localisation determination.

The installation specifications of the respective antennas shall prescribe requirements such that even potential side lobes do not violate where Balise information is read. This implies that an antenna with side lobes must be mounted closer to the axis than one without. UNISIG SUBSET-100 (Interface 'G') details the installation along the x-axis of antennas for existing KER systems.

For the purpose of evaluation of extension of lobes, Data for Balise Detection shall be used by the STM.

For the purpose of evaluation of telegram contents, Data for Telegram Detection shall be used by the STM.

The Signal Strength Data shall be used by the STM as guidance for securing selection of the main lobe. If such data is available, the lobe with the highest amplitude shall be selected as main lobe unless other criteria according to section 4.1.1.3.2 determine that the lobes belong to different Balises. The Signal Strength Data signal shall be considered available when the Signal Strength Data is anything else than that all the Signal Strength data bits are set to logical 'zeros'.

The Data for Balise Detection signal shall be the basis for localisation data. The midpoint between the beginning and end of the main lobe shall be used for localisation of the Balise.

If two or several lobes are detected as belonging to the same Balise, the lobe with highest peak amplitude shall be chosen to be the main lobe.

If the Signal Strength Data is not available, the lobe with the longest distance (between begin and end of lobe) shall be used for determining the main lobe of lobes concluded belonging to the same Balise.

Telegram contents and location data shall have the origin from the same lobe.

4.1.1.3.2 Algorithms

The following Table 5 shall be used when analysing a new lobe after an earlier received lobe. In the following it is assumed that the received lobes are evaluated and judged in consecutive sequence. Upon reception of the first lobe, it is initially assumed that it is the main lobe. In case a new lobe is detected within a distance between the centres of the lobes such that it can not be positively concluded that it belongs to a new Balise, it is further judged whether the new lobe is the main lobe (thus potentially overriding the earlier judgement on main lobe). Generally, a Balise shall be ended if it can be positively concluded that the evaluated distance from the centre of the latest determined main lobe is more than 1.7 m, if this lobe has ended and no new lobe has been detected.

Please observe the notes succeeding the table, which are applicable as motivations and/or clarifications.

	It is positively concluded that the evaluated distance between the centres of the new lobe and the main lobe is less than 0.8 m. ¹	It is <u>not</u> positively concluded that the evaluated distance between the centres of the new lobe and the main lobe is less than 0.8 m, and it is <u>not</u> positively concluded that the evaluated distance between the centres of the new lobe and the main lobe is more than 1.7 m. ²	It is positively concluded that the evaluated distance between the centres of the new lobe and the main lobe is more than 1.7 m. ³
Different telegrams in the analysed lobes. The telegrams positively indicate that they belong to different Balises. ⁴	In principle impossible, but if it happens, a new Balise should be assumed discovered. End the previous Balise. Start a new evaluation of a Balise with the recently detected lobe.	Conclude that a new Balise was discovered. End the previous Balise evaluation, if not already done. Start a new evaluation of a Balise with the recently detected lobe.	A new Balise was discovered. End the previous Balise evaluation if not already done. Start a new evaluation of a Balise with the recently detected lobe.
Identical telegram contents in the analysed lobes. ⁵	Conclude that the lobes are from the same Balise. Continue searching for additional lobes. After the end of the Balise, select the telegram and lobe of the main lobe as defined in section 4.1.1.3.1.	Check if data, assuming two Balises, are consistent with possible Balise group configuration (e.g., information from a speed board). If this is consistent with a Balise group, conclude that the lobes are from two different Balises, else conclude that they belong to the same Balise. Select the telegram and lobe of the main lobe as defined in section 4.1.1.3.1.	Conclude that the lobes come from two different Balises.
Different telegrams in the analysed lobes. The telegrams positively indicate that they belong to the same Balise. ⁶	Conclude that the lobes are from the same Balise. Continue searching for additional lobes. After the end of the Balise, select the telegram from the evaluated main lobe as defined in section 4.1.1.3.1 (unless any telegram is a restrictive aspect message).	Conclude that the lobes are from the same Balise. Continue searching for additional lobes. After the end of the Balise, select the telegram from the evaluated main lobe as defined in section 4.1.1.3.1 (unless any telegram is a restrictive aspect message).	In principle impossible, but if it happens, conclude that the lobes are from the same Balise. After ending the Balise, start evaluation of a new Balise. This is possibly due to unavailability in the odometer function.
Different telegrams in the analysed lobes. It is not possible, based on the telegram, to positively conclude whether the content belongs to the same Balise or not.	Conclude that the lobes are from the same Balise. Continue searching for additional lobes. After the end of the Balise, select the telegram from the evaluated main lobe as defined in section 4.1.1.3.1 (unless any telegram is a restrictive aspect message).	Both possibilities apply. The STM might be able to determine the situation. If not assume that a new Balise was discovered.	Conclude that a new Balise was discovered. End the previous Balise evaluation if not already done. Start a new evaluation of a Balise with the recently detected lobe.
Corrupted telegram in the analysed new lobe.	Conclude that the lobes are from the same Balise. Continue searching for additional lobes. After the end of the Balise, select the telegram from the evaluated main lobe as defined in section 4.1.1.3.1 (unless any telegram is a restrictive aspect message).	Conclude that a new Balise was discovered. End the previous Balise evaluation if not already done. Start a new evaluation of a Balise with the recently detected lobe.	Conclude that a new Balise was discovered. End the previous Balise evaluation if not already done. Start a new evaluation of a Balise with the recently detected lobe.

Table 5: Algorithms for management of side lobes

The following notes apply to Table 5:

1. The maximum distance between the centres of the main lobe and a side lobe belonging to the same Balise is 0.8 m. Please observe that this is the physical distances and that the STM must consider the actual speed/odometer inaccuracy before any conclusion.
2. The uncertainty in determination of distances might be caused by slip and slide phenomena. The odometer vital confidence interval has diverged such that a decision can not be made based on odometer data.
3. The minimum distance between succeeding Balises within a Balise Group is 2.3 m. Assume that the uncertainty of the extracted midpoint of consecutive main lobes can be maximum 0.6 m. (e.g., ± 0.3 m from the physical centres of the Balises). Then, it is defined vital to conclude that it is impossible that it is the centre of the same Balise if the detected distance is exceeding 1.7 m from the centre of the previous Balise main lobe. Please observe that this is the physical distances and that the STM must consider the actual speed/odometer inaccuracy before any conclusion.
4. This is possible in for example the Ebicab 900 telegram format, because there is a dedicated variable similar to the N_PIG variable in ERTMS/ETCS. Thus, it is possible to conclude that telegrams come from the same Balise even though the encoder has switched telegrams.
5. For data having its origin from a specific Balise, this is the normal case applicable to the vast majority of all cases. A few exceptions are thinkable, e.g., double directed speed signs with the same speed in the Ebicab 700 system.
6. This is possible in for example the Ebicab 900 telegram format, because there is a dedicated variable similar to the N_PIG variable in ERTMS/ETCS. Thus, it is possible to conclude that telegrams come from the same Balise even though the encoder has switched telegrams.

4.1.1.4 Checking of the Interface 'K' signals

S The requirement on Interface 'K' is a tolerable hazard rate of less than what is defined in section 5.3.2.1 on page 50 with respect to the ability to detect Balises. The quantitative target only concern failures in the supervision of data from Interface 'K'.

The data rate shall be checked to be 50 kbit/s. The data rate shall be evaluated such that maximum 0.5 ASK bit discrepancy is allowed over an evaluation period corresponding to one full telegram.

In case the link is set such that there is no link activity (including no BPL coding) during operation, the transmission from the BTM function is either malfunctioning (and the STM shall treat the link as failed), or the toggling modulation was switched off.

The Interface 'K' channels must be checked periodically as they may normally be transmitting logical 'one' BD and TD data for a long time. The STM shall perform evaluation of link tests transmitted by the BTM function. The STM shall in general verify that at least one link test is correct during a 250 ms period (sliding window). However, this period of time may be prolonged up to a maximum of 1 s in case it is determined that at least three 'zeros' of BD data are received during 32 consecutive ASK bits (thus indicating Balise reception) at the end of the period. After the maximum time 1 s has elapsed, but not less than 0.5 s, the BTM function shall transmit a link test regardless of if Balise reception is in progress or not. During a link test, the Link Test Data shall go to logical 'one', and the STM shall not consider data received as part of a Balise transmission. This presumes the STM to accept to receive link-tests during some conditions also in the presence of a Balise at low speed. See further details in section 4.1.2.2 on page 35.

To avoid errors in Link Test Data, Eurobalise Reception data, or ERTMS Unavailability data causing the system to ignore KER Balises, the channel shall be considered failed if these stay at logical 'one' for more than 5 m of physical movement. See also section 3.1.6 on page 20.

A single failure in the STM should not create a situation such that identical information is erroneously produced in two or several channels.

In case the check of Interface 'K' indicates a fault, the STM may not go to Failure State, but may lose its supervision state. This is because there are several sporadic reasons for losing the supervision signal, such as changing antenna due to redundancy, changing antenna due to change of cab, excessive noise in the air-gap, and possibly deactivation of Tele-powering.

4.1.1.5 Detection of Bit Errors

Bit errors will implicitly be detected simultaneously with checking of data with respect to the applicable coding strategies. See also section 4.1.1.6 below.

4.1.1.6 Checking of Data with respect to Coding Requirements

There are possible situations where the received signal is very strong, i.e., very much above the threshold for safe detection. In such cases, ASK with fixed threshold is still susceptible to noise and also to off-state attenuation in the Balises. An adaptive threshold can improve the error rate in the decoded data. The optional output of optimally decoded data (Data for Telegram Detection) allows the BTM function to provide both the safe data and the optimal data. The STM can then use the safe data for detection of Balises and optimal data for data recovery.

The On-board Transmission Equipment gives a consecutive sequence of error free bits with the minimum duration as defined in Ref. [4] (depending on the type of coding). The On-board Transmission Equipment shall have a reliable contact distance to facilitate sufficient number of repetitions of this minimum sequence to achieve sufficient reliability. In case of repetition of telegram in two Balise Groups, this shall be treated as a repetition for reliability. The STM shall be able to receive and buffer as many data bits as possible (dependent on duration of Balise passage), and in this sequence analyse all possible combinations such that a minimum length of correct sequence is not missed. A sequence of at least 2000 consecutive bits (if available) shall be analysed.

4.1.1.7 Extraction of User Data

The information sent in the air gap shall be encoded according to the requirements of the applicable KER system coding strategy. The STM shall be responsible for performing the related decoding (thus extracting the plain user data). Where applicable, the STM is also responsible for compiling data from all Balises in a Balise Group such that the appropriate Balise Group information is evaluated and supervised.

4.1.1.8 Telegram Filtering

During a Balise passage, several telegrams are normally transmitted via Interface 'K' to the STM. In such a case, the STM shall perform filtering such that only one message is finally evaluated and supervised.

4.1.1.9 Management of Telegram Switching

During a Balise passage, there is a possibility that the telegram sent from the encoder is altered (e.g., due to a change of the signal aspect). The STM shall be responsible for handling such a situation in a proper way.

4.1.1.10 Time and Odometer Stamping of Output Data

The BTM function will not perform time and odometer stamping of KER data. This has to be performed by the STM. This is defined in Ref. [2].

4.1.1.11 Support to Localisation

Support to localisation shall be provided by the STM. A critical thing is to be able to separate succeeding Balises also when considering the management of side lobe effects.

4.1.1.12 Eurobalise Suppression

In order to make it possible for the STM to extract user data according to the applicable coding strategy, it is necessary to have knowledge of if Eurobalise created bits are transmitted via Interface 'K'. In such a case, the information (including the related Balise Detect event) shall be ignored by the STM. This shall be performed using the Eurobalise Reception data provided by the BTM function. See also section 4.1.2.6 on page 39.

S Please observe that it is a safety-related issue to not erroneously suppress also KER Balises.

In the Ebicab 700/900, L10000, and RSDD systems, it is an availability requirement not to report a Eurobalise passage as a KER Balise passage to the STM. However, please observe the constraints defined in section 4.1.5 on page 41.

S For KVB, there is a safety requirement on the combined event that the intended ASK Balise is not detected and that a nearby Eurobalise is erroneously reported as an ASK marker Balise. This combined situation shall not occur with a higher wrong side failure rate than 10^{-9} failures/hour.

4.1.1.13 Management of Antenna Distances

All necessary information on where the antennas are mounted on the vehicle shall be entered into and stored within the STM if necessary. This allows the STM to check that this data is compatible with the use of the specific STM upon start-up.

4.1.1.14 Suppression of data during Interface 'K' and/or transmission tests

Checking of signals for Interface 'K' supervision may be done simultaneously with the supervision of the safe integrity of the Balise Detect capability.

4.1.1.15 Managing various Architectures

As defined in section 3.1.1 on page 13, the BTM function may transmit data on one single channel (the 'a' channel), or use several channels for the purpose of enhanced safety and/or availability. Configuration data shall be stored within the STM in order to recognise which architecture is actually implemented in a specific system.

4.1.2 ERTMS/ETCS Functionality

4.1.2.1 Overview

Table 6 below defines the Interface ‘K’ specific functionality of the ERTMS/ETCS.

ERTM/ETCS functionality:
Integrity of the BTM function
Command toggling mode on/off
Selection of the Interface ‘G’ variant to read KER Balises
Command Tele-powering on/off
Eurobalise Detection
Selection of antenna due to the active cab
Selection of BTM function and/or antenna due to redundancy

Table 6: ERTMS/ETCS functionality

Since the Interface ‘K’ and its use is tightly related to the Interface ‘G’ and the system oriented functionality, Table 6 should be read with considerations to the On-board Transmission Equipment functionality defined in Ref. [4] and the STM functionality defined in section 4.1.1 on page 26.

4.1.2.2 Integrity of the BTM function

According to the current specification of the ERTMS/ETCS system, the ERTMS/ETCS On-board is responsible for the integrity of the ERTMS/ETCS On-board equipment which includes the On-board Transmission Equipment (BTM function and antenna(s)). In case the On-board Transmission Equipment implements Interface ‘G’ and Interface ‘K’, the integrity for operation in the corresponding modes for the KER STM’s (defined in Ref. [4]) shall be included in the responsibility of the ERTMS/ETCS On-board for the integrity of the ERTMS/ETCS On-board equipment.

The normal operation of the On-board Transmission Equipment shall be reported to the STM’s using the Eurobalise Reception data, ERTMS Unavailability data, and Link Test data (see section 3.1.2 on page 15).

In case of a failure categorised as permanent within the On-board Transmission Equipment, the link communication shall be aborted, which is defined as absence of link activity on the Interface ‘K’ (including no BPL coding).

The ERTMS/ETCS On-board Transmission Equipment may report sporadic unavailability (setting the ERTMS Unavailability data to logical ‘one’), for example, in case the On-board Transmission Equipment has a sporadic loss of integrity.

The On-board Transmission Equipment shall initiate regular tests of Interface 'K' (see also section 4.1.1.4 on page 31)⁷. The testing shall comprise transmission of four mandatory consecutive ASK bits with the data defined below. The length of the link test pattern may optionally be extended with a maximum of 15 additional bits (allowing that the antenna test in the BTM/antenna is transparently transmitted after the four mandatory bits). However, the Link Test data shall consistently reflect the actual length of the link test such that no erroneous Balise Detect is created.

Bit 1:

- Data for Balise Detection (BD) is set to logical 'zero'
- Data for Telegram Decoding (TD) is set to logical 'zero'
- ERTMS Unavailability data (EU) is set to logical 'zero'
- Eurobalise Reception data (EB) set to logical 'zero'
- Link Test Data (LT) is set to logical 'one'
- Signal Strength Data (S) set to 0000
- Antenna/BTM ID Data (A) set to the correct source
- Link ID Data (L) set to the intended link
- CRC is set such that it is correct

Bit 2:

- Data for Balise Detection (BD) is set to logical 'zero'
- Data for Telegram Decoding (TD) is set to logical 'zero'
- ERTMS Unavailability data (EU) is set to logical 'zero'
- Eurobalise Reception data (EB) set to logical 'zero'
- Link Test Data (LT) is set to logical 'one'
- Signal Strength Data (S) set to 0000
- Antenna/BTM ID Data (A) set to the correct source
- Link ID Data (L) set to intended link
- CRC is set such that it is corrupted⁸

Bit 3:

- Data for Balise Detection (BD) is set to logical 'one'
- Data for Telegram Decoding (TD) is set to logical 'one'
- ERTMS Unavailability data (EU) is set to logical 'one'
- Eurobalise Reception data (EB) set to logical 'one'
- Link Test Data (LT) is set to logical 'one'
- Signal Strength Data (S) set to 1111
- Antenna/BTM ID Data (A) set to the bit wise inversion of the correct source
- Link ID Data (L) set to the bit wise inversion of the intended link
- CRC is set such that it is correct

⁷ The BTM should avoid transmission of link tests during a Balise contact (see section 4.1.1.4 on page 30 regarding delay of the link test). In case a link test is still performed during a Balise contact, it is the responsibility of the ERTMS/ETCS to ensure that the remaining contact distance is sufficient for Balise Detection and telegram decoding (see specification in UNISIG SUBSET-100).

⁸ The CRC shall be generated based on all information bits inverted (but the actually transmitted bits shall not be inverted).

Bit 4:

- Data for Balise Detection (BD) is set to logical 'zero'
- Data for Telegram Decoding (TD) is set to logical 'one'
- ERTMS Unavailability data (EU) is set to logical 'zero'
- Eurobalise Reception data (EB) set to logical 'one'
- Link Test Data (LT) is set to logical 'one'
- Signal Strength Data (S) set to 0101
- Antenna/BTM ID Data (A) set to the correct source
- Link ID Data (L) set to the intended link
- CRC is set such that it is correct

4.1.2.3 Command Toggling mode on/off

In case the On-board Transmission Equipment of the ERTMS/ETCS On-board includes the transmission for KER STM's (Interface 'G' and Interface 'K'), the ERTMS/ETCS On-board shall be responsible to command toggling mode on/off:

- When a KER STM is ordered by the ERTMS/ETCS On-board from the state CS (Cold Standby) to the states HS (Hot Standby) or DA (Data Available), the ERTMS/ETCS On-board shall command Toggling mode on.
- In all other cases, the ERTMS/ETCS On-board may select either CW or toggling Tele-powering.

The detection of a KER STM within the ERTMS/ETCS On-board shall be done by means of the NID_STM. The activation of Toggling modulation and Interface 'K' is based on configuration data in the ERTMS, which takes into account whether the STM has its own antenna or not.

The STM will connect to the ERTMS/ETCS On-board via the STM FFFIS at start-up and transmit its NID_STM (see Ref. [2]) so that the ERTMS/ETCS On-board is able to detect a KER STM based on the transmitted NID_STM. In case a KER STM connects to an ERTMS/ETCS On-board and the On-board Transmission Equipment of the ERTMS/ETCS On-board is not able to process information from the trackside of this KER STM, the ERTMS/ETCS On-board shall close the connection to this STM (STM Control Connection, see Ref. [2]). In this case, the STM will not be added to the list of available STM's by the ERTMS/ETCS On-board and therefore will not be considered for level transitions (see Ref. [2] and Ref. [6]).

4.1.2.4 Selection of the Interface ‘G’ variant to read KER Balises

Interface ‘G’ defines the characteristics and the performance of the air gap between the KER Balises and the On-board Transmission Equipment (see Ref. 4). The KER Balises of Interface ‘G’ can be of various types with specific air gap interfaces, which leads to different variants of Interface ‘G’ (G_A, G_B, G_C, G_D, and G_E).

In order to read the Balises of a KER STM, the ERTMS/ETCS On-board has to select the corresponding variant of Interface ‘G’. This function shall be performed by means of the NID_STM (see section 4.1.2.3). When toggling mode is commanded ‘on’ by the ERTMS/ETCS On-board, the ERTMS/ETCS On-board shall select the variant of Interface ‘G’ according to the NID_STM of the STM in state “hot standby” or “data available”.⁹

4.1.2.5 Command Tele-powering on/off

According to the current specification of the ERTMS/ETCS system, Tele-powering will be switched off by the On-board Transmission Equipment only based on an announcement for big metal masses (see Ref. [6]), since big metal masses on the track may lead to an indication of failure of the On-board Transmission Equipment. If this functionality is triggered in Level STM, this would cause a failure in the STM. The announcement of big metal masses should be avoided in KER areas.

In case the Tele-powering is unintentionally switched off, the ERTMS/ETCS On-board shall set ‘ERTMS Unavailability Data’ to logical ‘one’. The ERTMS/ETCS strategy that Tele-powering is not switched off during stand still at stations applies for systems equipped with Interface ‘K’.

⁹ As the On-board Transmission Equipment cannot read Balises from different KER STM’s at the same time, no direct transitions between KER STM’s using the Interface ‘K’ is possible.

4.1.2.6 Eurobalise Detection

The main lobe of a Eurobalise fulfils the requirements defined in section “Contact Volume Requirements” of UNISIG SUBSET-100 (Ref. [4]).

The herein defined start of Interface ‘K’ lobe is when there is at least three ‘zeros’ of BD data received within a floating window of 32 consecutive ASK bits. The last of these ‘zeros’ is the first bit of the lobe.

The Interface ‘K’ lobe has ended when 16 consecutive ASK ‘ones’ have been received. The last bit in the lobe is the ‘zero’ preceding the 16 ‘ones’.

The following applies:

- Eurobalise shall be indicated by ETRMS/ETCS, using the ‘Eurobalise Reception data’ (EB data), at the latest at a time corresponding to 32 ASK bits after the defined “start of Interface ‘K’ lobe”.
- The STM makes a preliminary decision on FSK at a time corresponding to 32 ASK bits after the ERTMS indicated “Eurobalise”.
- The STM normally makes a firm decision on FSK at a time corresponding to 80 ASK bits after the defined “start of Interface ‘K’ lobe”.
- The decision may be changed by the ERTMS/ETCS at any time before a time corresponding to 80 ASK bits after the defined “start of Interface ‘K’ lobe”, and data shall immediately be treated as ASK data by the STM after the instant the EB data is re-set to ‘zero’.
- Data received by the STM before a time corresponding to 80 ASK bits after the defined “start of Interface ‘K’ lobe” shall be used for ASK Balise Detection in case the decision is changed by the ERTMS/ETCS.
- If the decision made by the ERTMS/ETCS is changed after a time corresponding to 80 ASK bits after the defined “start of Interface ‘K’ lobe”, no change of decision for the entire lobe shall be performed by the STM when the speed is above 10 m/s. For speeds below 10 m/s, the STM shall change a decision on ASK data in case the ERTMS uninterruptedly indicated “Eurobalise” for a period of time exceeding 10 ms during the lobe. Such a potential change of decision from ASK to FSK during low speed conditions shall be irrevocable.
- A decision for the main lobe overrides potential decisions from side lobes.

Please observe that Eurobalise lobes with shorter duration than the definition of UNISIG SUBSET-100 may not be marked with EB data set to ‘one’. However, during specified conditions, all fault free Eurobalises provides main lobes that are longer than 1.6 ms. Side lobe properties for Eurobalises are in accordance with the notes associated with Table 5 on page 29.

4.1.2.7 Selection of Antenna due to the active cab

The active cab is reported to the STM's via the STM FFFIS (defined in Ref. [2] and [3]).

The ERTMS/ETCS On-board may need to transmit sporadic unavailability during the switch-over between the antennas for the different travel directions.

The ERTMS/ETCS Onboard shall be responsible for changing antennas. It is also responsible to inform the STM about the current Antenna/BTM function ID as specified in Ref. [2] section 10.15. The STM shall be responsible to check that the antenna/BTM function ID is suitable for the national system. In case the antenna/BTM function ID is not suitable, the transmission shall be regarded as failed.

It is not allowed to perform switching of antenna/BTM function except during stand still. Potential data transmitted during the switch shall be marked invalid (using the ERTMS Unavailability data), or the absence of link activity shall occur.

4.1.2.8 Selection of BTM function and/or antenna due to redundancy

In case the On-board Transmission Equipment implements redundant BTM functions and/or antennas for availability reasons, the ERTMS/ETCS On-board shall be responsible for the redundancy switch-over of the BTM function as well as of the antenna.

The ERTMS/ETCS On-board shall report to the STM's using the Antenna/BTM ID data whether the normal or the redundant antenna is currently being used.

The ERTMS/ETCS On-board may need to transmit sporadic unavailability during the redundancy switch-over.

Redundancy switch-over is only allowed in combination with a re-start of the transmission system (i.e., the train must be at stand still and a complete re-start and re-configuration of the transmission system shall be performed).

It is the responsibility of the ERTMS/ETCS to decide on the suitability of redundant antennas. A message shall be sent to the driver if the STM is not usable with the selected antenna.

- S** It not allowed to switch to a redundant antenna being positioned further ahead in the intended direction of travelling.

4.1.3 Odometer Requirements for Side Lobe Handling

The odometer data shall be good enough to allow the STM to distinguish between a distance of 1.7 m and 2.3 m under nominal conditions, assuming that the STM is using the formulas for distance confidence calculations in Ref. [2]. This is an availability requirement.¹⁰

The odometer data shall be good enough to allow the STM to positively distinguish between the distances defined in Table 5 on page 29 and enabling sufficient availability in the related evaluations.

4.1.4 Balise Separation

See UNISIG SUBSET-100 (Ref. [4]).

4.1.5 Balise Group Separation

- S In the Ebicab 700/900, and L10000 systems, the shortest distance between a KER Balise of one group and a Eurobalise of another group is 10.5 m in case KER marker Balises are involved.
- S In the RSDD system, the shortest distance between a KER Balise of one group and a Eurobalise of another group is 30 m in case KER marker Balises are involved.

¹⁰ The distance measurement accuracy should therefore be better than 0.3 m for distances around 2 m. Under the condition that tolerance contributions from relative and stochastic factors are ignored, this leads to Absolute Distance Accuracy N_D_Abs less than 0.3 m, and consequently Odometer Resolution Res_Odo less than 0.15 m.

4.2 Alternative 2

4.2.1 STM Functionality

4.2.1.1 Overview

See section 4.1.1.1 on page 26.

4.2.1.2 Detection of Balises

See section 4.1.1.2 on page 27.

4.2.1.3 Management of Side Lobe Effects

Assuming that the side lobes are short, relevant parts of section 4.1.1.3 on page 27 apply. It is required that the STM can correctly cope with side lobes that have shorter physical distance than 25 cm. This alternative 2 does not support any distribution of signal strength information. The lobe with the longest distance (between begin and end of lobe) shall be used for determining the main lobe of lobes concluded belonging to the same Balise. Please observe the constraint of section 4.2.2.9 on page 48.

Telegram contents and location data shall have the origin from the same lobe.

4.2.1.4 Checking of the Interface 'K' signals

S The requirement on Interface 'K' is a tolerable hazard rate of less than what is defined in section 5.3.2.1 on page 50 with respect to the ability to detect Balises. The quantitative target only concern failures in the supervision of data from Interface 'K'.

The data rate shall be checked to be 50 kbit/s. The data rate shall be evaluated such that maximum 0.5 ASK bit discrepancy is allowed over an evaluation period corresponding one full telegram.

The Interface 'K' channels must be checked periodically as they may normally be transmitting logical 'one' data for a long time. The STM shall perform evaluation of link tests transmitted by the BTM function. The STM shall in general verify that at least one link test is correct during a 500 ms period (sliding window).

The link test sequence will be the following. The Data signal shall be switched to logical 'zero' for the duration between 40 μ s and 600 μ s, while the CLK signal is active. Then, the Data signal will be switched to logical 'one' and CLK to logical 'zero' for the duration between 40 μ s and 600 μ s. The total sequence of the test shall be less than 640 μ s. Figure 11 illustrates the waveform at a link test.

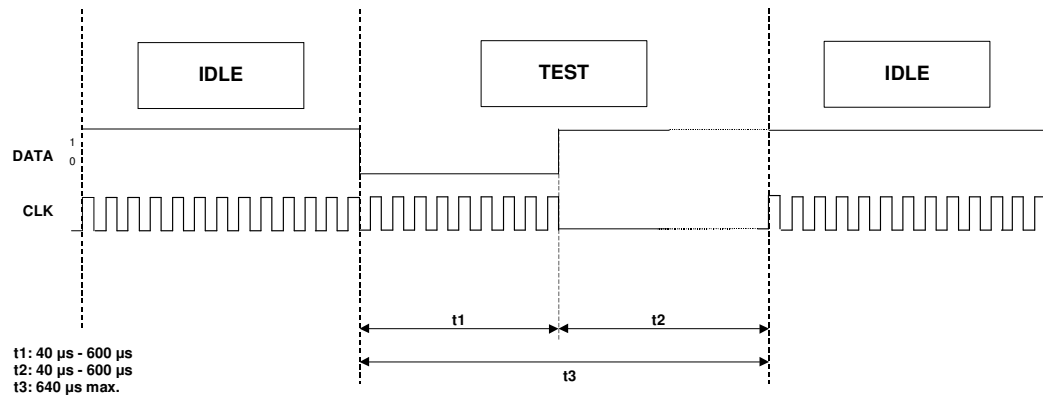

Figure 11: Waveform of the signals at a link test

A single failure in the STM should not create a situation such that identical information is erroneously produced in two or several channels.

In case the check of Interface 'K' indicates a fault, the STM may not go to Failure State, but may lose its supervision state. This is because there are several sporadic reasons for losing the supervision signal, such as changing antenna due to redundancy, changing antenna due to change of cab, excessive noise in the air-gap, and possibly deactivation of Tele-powering.

4.2.1.5 Detection of Bit Errors

See section 4.1.1.5 on page 31.

4.2.1.6 Checking of Data with respect to Coding Requirements

The On-board Transmission Equipment gives a consecutive sequence of error free bits with the minimum duration as defined in Ref. [4] (depending on the type of coding). The On-board Transmission Equipment shall have a reliable contact distance to facilitate sufficient number of repetitions of this minimum sequence to achieve sufficient reliability. In case of repetition of telegram in two Balise Groups, this shall be treated as a repetition for reliability. The STM shall be able to receive and buffer as many data bits as possible (dependent on duration of Balise passage), and in this sequence analyse all possible combinations such that a minimum length of correct sequence is not missed. In general, at least 2000 consecutive bits (if available) shall be analysed.

4.2.1.7 Extraction of User Data

See section 4.1.1.7 on page 33.

4.2.1.8 Telegram Filtering

See section 4.1.1.8 on page 33.

4.2.1.9 Management of Telegram Switching

See section 4.1.1.9 on page 33.

4.2.1.10 Time and Odometer Stamping of Output Data

See section 4.1.1.10 on page 33.

4.2.1.11 Support to Localisation

See section 4.1.1.11 on page 33.

4.2.1.12 Eurobalise Suppression

In order to make it possible for the STM to extract user data according to the applicable coding strategy, it is necessary to have knowledge of if Eurobalise crated bits are transmitted via Interface 'K'. In such a case, the information (including the related Balise Detect event) shall be ignored by the STM. See also section 4.2.2.6 on page 46.

S Please observe that it is a safety-related issue to not erroneously suppress also KER Balises.

In the Ebicab 700/900, L10000, and RSDD systems, it is an availability requirement not to report a Eurobalise passage as a KER Balise passage to the STM. However, please observe the constraints defined in section 4.2.5 on page 48.

S For KVB, there is a safety requirement on the combined event that the intended ASK Balise is not detected and that a nearby Eurobalise is erroneously reported as an ASK marker Balise. This combined situation shall not occur with a higher wrong side failure rate than 10^{-9} failures/hour.

4.2.1.13 Management of Antenna Distances

See section 4.1.1.13 on page 34.

4.2.1.14 Suppression of data during Interface 'K' and/or transmission tests

See section 4.1.1.14 on page 34.

4.2.1.15 Managing various Architectures

See section 4.1.1.15 on page 34.

4.2.2 ERTMS/ETCS Functionality

4.2.2.1 Overview

Table 7 below defines the Interface 'K' specific functionality of the ERTMS/ETCS.

ERTM/ETCS functionality:
Integrity of the BTM function
Command toggling mode on/off
Selection of the Interface 'G' variant to read KER Balises
Command Tele-powering on/off
Eurobalise Detection
Selection of antenna due to the active cab
Selection of BTM function and/or antenna due to redundancy
Side Lobe Suppression

Table 7: ERTMS/ETCS functionality

Since the Interface 'K' and its use is tightly related to the Interface 'G' and the system oriented functionality, Table 7 should be read with considerations to the On-board Transmission Equipment functionality defined in Ref. [4] and the STM functionality defined in section 4.1.1 on page 26.

4.2.2.2 Integrity of the BTM function

According to the current specification of the ERTMS/ETCS system, the ERTMS/ETCS On-board is responsible for the integrity of the ERTMS/ETCS On-board equipment that includes the On-board Transmission Equipment (BTM function and antenna(s)). In case the On-board Transmission Equipment implements Interface 'G' and Interface 'K', the integrity for operation in the corresponding modes for the KER STM's (defined in Ref. [4]) shall be included in the responsibility of the ERTMS/ETCS On-board for the integrity of the ERTMS/ETCS On-board equipment.

In case of a failure, permanent or sporadic, within the On-board Transmission Equipment, the CLK signal shall be at constant polarity for more than 500 ms. This is also the consequence of a power loss to the BTM.

If the STM is in state HS or DA and the CLK signal is at constant polarity for more than 500 ms, the STM shall treat it as a system failure within the On-board Transmission Equipment.

The On-board Transmission Equipment shall initiate regular tests of Interface 'K', see section 4.2.1.4 on page 42.

4.2.2.3 Command Toggling mode on/off

See section 4.1.2.3 on page 37.

4.2.2.4 Selection of the Interface ‘G’ variant to read KER Balises

See section 4.1.2.4 on page 38.

4.2.2.5 Command Tele-powering on/off

According to the current specification of the ERTMS/ETCS system, Tele-powering will be switched off by the On-board Transmission Equipment only based on an announcement for big metal masses (see Ref. [6]), since big metal masses on the track may lead to an indication of failure of the On-board Transmission Equipment. If this functionality is triggered in Level STM, this would cause a failure in the STM. The announcement of big metal masses should be avoided in KER areas.

In case the Tele-powering is intentionally or unintentionally switched off, this shall be regarded as a failure. See section 4.2.2.2 on page 45.

If the STM is in state HS or DA and the CLK signal is at constant polarity for more than 500 ms, the STM shall treat it as a system failure within the On-board Transmission Equipment.

The ERTMS/ETCS strategy that Tele-powering is not switched off during stand still at stations applies for systems equipped with Interface ‘K’.

4.2.2.6 Eurobalise Detection

The main lobe of a Eurobalise fulfils the requirements defined in section “Contact Volume Requirements” of UNISIG SUBSET-100 (Ref. [4]).

The herein defined start of Interface ‘K’ lobe is when there is at least three ‘zeros’ of data received within a floating window of 32 consecutive ASK bits. The last of these ‘zeros’ is the first bit of the lobe.

The Interface ‘K’ lobe has ended when 16 consecutive ASK ‘ones’ have been received. The last bit in the lobe is the ‘zero’ preceding the 16 ‘ones’.

The following applies:

- Eurobalise shall be indicated by ETRMS/ETCS, by forcing Data to ‘one’ and the CLK to ‘zero’, at the latest at a time corresponding to 32 ASK bits after the defined “start of Interface ‘K’ lobe”. Figure 12 below illustrates the waveform of all signals at Eurobalise passage.
- The STM makes a preliminary decision on FSK at a time corresponding to 32 ASK bits after the ERTMS indicated “Eurobalise”.
- The STM normally makes a firm decision on FSK at a time corresponding to 80 ASK bits after the defined “start of Interface ‘K’ lobe”.
- The decision may be changed by the ERTMS/ETCS at any time before a time corresponding to 80 ASK bits after the defined “start of Interface ‘K’ lobe”, and data shall immediately be treated as ASK data by the STM after the instant the EB data is re-set to ‘zero’.
- Data received by the STM before a time corresponding to 80 ASK bits after the defined “start of Interface ‘K’ lobe” shall be used for ASK Balise Detection in case the decision is changed by the ERTMS/ETCS.
- If the decision made by the ERTMS/ETCS is changed after a time corresponding to 80 ASK bits after the defined “start of Interface ‘K’ lobe”, no change of decision for the entire lobe shall be performed by the STM when the speed is above 10 m/s. For speeds below 10 m/s, the STM shall change a decision on ASK data in case the ERTMS uninterruptedly indicated “Eurobalise” for a period of time exceeding 10 ms during the lobe. Such a potential change of decision from ASK to FSK during low speed conditions shall be irrevocable.

- A decision for the main lobe overrides potential decisions from side lobes.

Please observe that Eurobalise lobes with shorter duration than the definition of UNISIG SUBSET-100 may not be marked with EB data set to 'one'. However, during specified conditions, all fault free Eurobalises provides main lobes that are longer than 1.6 ms. Side lobe properties for Eurobalises are in accordance with the notes associated with Table 5 on page 29.

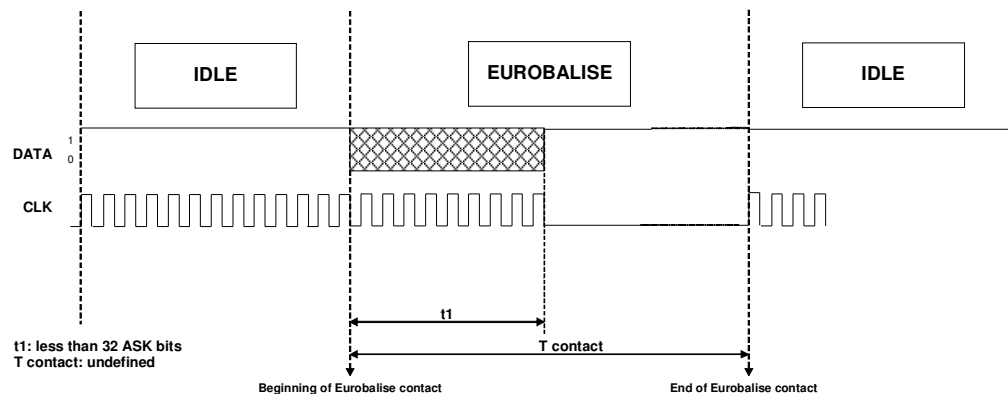

Figure 12: Waveform of the signals related to the “EUROBALISE” mode.

In the case of a train passing at low speed over a Eurobalise, the CLK signal shall be periodically reactivated for the duration less than 32 ASK bits in order to allow the failure management of the BTM to STM link on the STM side. This CLK reactivation cycle time shall be lower than 500 ms.

4.2.2.7 Selection of Antenna due to the active cab

The active cab is reported to the STM's via the STM FFFIS (defined in Ref. [2] and [3]).

The ERTMS/ETCS shall be responsible for changing antennas and to inform the STM about the current Antenna/BTM function ID.

It is not allowed to perform switching of antenna/BTM function except during stand still. Potential data transmitted during the switch-over shall be ignored by the STM.

4.2.2.8 Selection of BTM function and/or antenna due to redundancy

In case the On-board Transmission Equipment implements redundant BTM functions and/or antennas for availability reasons, the ERTMS/ETCS On-board shall be responsible for the redundancy switch-over of the BTM function as well as of the antenna.

Redundancy switchover is only allowed in combination with a re-start of the transmission system (i.e., the train must be at stand still and a complete re-start and re-configuration of the transmission system shall be performed).

It is the responsibility of the ERTMS/ETCS to decide on the suitability of redundant antennas. A message shall be sent to the driver if the STM is not usable with the selected antenna.

Potential data transmitted during the switchover shall be ignored by the STM

- S** It not allowed to switch to a redundant antenna being positioned further ahead in the intended direction of travelling.

4.2.2.9 Side Lobe Suppression

Potential side lobes shall not result in transmission that is longer than the transmission from the associated main lobe of the Balise.

4.2.3 Odometer Requirements for Side Lobe Handling

See section 4.1.3 on page 41.

4.2.4 Balise Separation

See section 4.1.4 on page 41.

4.2.5 Balise Group Separation

See section 4.1.5 on page 41.

5 RAMS Requirements

5.1 Transmission System Aspects

Aspects related to the entire transmission system are dealt with in Ref. [4], UNISIG SUBSET-100.

5.2 Balise Aspects

Aspects related to the Balise are dealt with in Ref. [4], UNISIG SUBSET-100.

5.3 On-board Transmission Equipment and STM Aspects

5.3.1 General

As KER Balise systems have less data available than the ERTMS/ETCS system using Eurobalises, some of the KER systems have less logical linking supervision (ability to find missing/faulty Balises). This requires strict supervision of proper operation of the BTM function, Interface 'G', and Interface 'K' to ensure that Balise groups are not missed because of failures in the On-board Transmission Equipment or the STM.

Supervision is not required and shall not be performed other than when the STM is in state HS (Hot Standby) state or DA (Data Available) state.

The combination of ERTMS/ETCS and On-board Transmission Equipment supervises that the transmission system is operational. If an error only related to STM, which can not be communicated via Interface 'K', is detected, the STM shall be shut down by being ordered to FA (Failure) state by the ERTMS/ETCS Kernel.

In UNISIG SUBSET-100 (see Ref. [4]), there are quantitative targets on the On-board Transmission Equipment concerning failures that can not be detected by the supervision functions of the STM.

Interface 'K' shall not manipulate data to the effect that any other correct telegram is produced. It should also not corrupt data, since that would reduce the availability of the STM operation.

The manipulation allowed can be generalised to memory-less delays and memorisation of less than complete telegrams, which can be as short as 32 bits. Data shall be sent on Interface 'K' in the same order as received from the Interface 'G'.

The consideration above is judged ensuring that the contributing THR from an Interface 'K' perspective is less than or equal to the level quantified via section 5.3.2.1 on page 50.

5.3.2 Safety Integrity Requirements related to Interface ‘K’

5.3.2.1 Quantification

Table 8 defines the requirements that shall be fulfilled for the STM functionality failure modes when assuming that the specified maintenance is fulfilled.

The quantitative targets of Table 8 below are system specific and are found in Annex A, Annex B, Annex C, and Annex D respectively. The targets only concern failures in the supervision of data from Interface ‘K’.

Additional measures beyond ERTMS/ETCS (either on the ERTMS/ETCS side or on the STM side) might be necessary to fulfil the requirements considering that the rate of failure for the ERTMS/ETCS On-board Equipment to detect a Balise Group, as defined in UNISIG SUBSET-036 (Ref. [1]), might be less demanding than the targets specified in the applicable annexes of this specification.

		Balise group
No.	Failure Mode Description	WSF rate [f/h]
FM1 _K	A Balise Group is not detected when indicating safe operation	System specific
FM2 _K	Storage of more than 31 bits of data, or data is not delivered in the same order as in the air-gap	System specific

Table 8: Targets for STM functionality

The figures might originate from a hardware failure, and are thus dependent on MTTR (including the detection time) and the actual failure frequency. The combination of these aspects is the sums quantified in Annex A, Annex B, Annex C, and Annex D respectively.¹¹

5.3.2.2 Independence of failure mode causes

Dependencies also have to be considered when calculating the figures of Table 8 on page 50.

¹¹ In which relation those failure modes are related to safety is determined by hazard analyses on higher system level.

5.3.2.3 Conditions/Assumptions

The apportionment of the figures of Table 8 on page 50 is based on the following presumptions:

- The Mean Time to Restore (MTTR) is irrelevant for the purpose of the quantification included via section 5.3.2.1 on page 50 (a faulty On-board Transmission Equipment or STM results in the vehicle being taken out of operation).
- The mean time for detection of On-board Transmission Equipment and STM failures is company specific, and might differ between the various failure modes of section 5.3.2.1 on page 50. The Mission Profile defined in higher system level documentation shall be considered in the company specific choices.
- Only random aspects are included.
- All figures are based on mean detection times. The analyses should be supported by sensitivity analyses wherever deemed necessary.
- For the purpose of failure mode FM2_K, it is assumed that a selection of continuous parts is sent in the same order as the data is received. Data must not be memorised in such a way that it can be sent more than once.

The following aspects are not within the scope of the quantification of Table 8 on page 50:

- Vandalism
- Exceptional occurrences (e.g., exceptional environmental conditions outside specification)
- Erroneous installation
- Erroneous maintenance
- Occupational Health
- Mechanical damage due to maintenance (causing conditions outside specification)

The quantification should, as far as possible, be based on data acquired by experience. If such data is not available, data from MIL-HDBK 217 or other similar recognised database should be used. Data may be tailored considering manufacturer experience (if available), but explicit justifications are required.

6 References

Ref. Number	Document number	Description
1	UNISIG SUBSET-036	FFFIS for Eurobalise
2	UNISIG SUBSET-035	Specific Transmission Module FFFIS
3	UNISIG SUBSET-058	FFFIS STM Application Layer
4	UNISIG SUBSET-100	Interface 'G' Specification
5	EN 50155 Issue August 2001	Railway applications, Electronic equipment used on rolling stock
6	UNISIG SUBSET-026	System Requirements Specification ERTMS/ETCS
7	EIA 485 Issue April 1983	Standard for Electrical Characteristics of Generators and Receivers for Use in Balanced Digital Multipoint Systems

Annex A, On-board Type 1 Specifics

A1 General

This annex applies to the Ebicab 700 and L 10000 systems only.

A2 Safety Integrity Requirements

No.	Failure Mode Description	Balise group
		WSF rate [f/h]
FM1 _K	A Balise Group is not detected when indicating safe operation ¹²	10 ⁻¹¹
FM2 _K	Storage of more than 31 bits of data, or data is not delivered in the same order as in the air-gap	10 ⁻¹¹

Table 9: Quantification for the Ebicab 700 and L 10000 systems

An SIL level of SIL 4 applies to the Ebicab 700 and L 10000 systems.

A3 Maximum number of consecutive ‘ones’

The maximum number of consecutive ‘ones’ allowed by the coding strategy for this system is 6.

¹² This target is more demanding than the corresponding ERTMS/ETCS requirement defined in SUBSET-036. This target might be based on other criteria than those defined in existing CENELEC standards (because CENELEC standards did not exist when the system was implemented). Specific justifications might be needed.

Annex B, On-board Type 2 Specifics

B1 General

This annex applies to the Ebicab 900 system only.

B2 Safety Integrity Requirements

No.	Failure Mode Description	Balise group
		WSF rate [f/h]
FM1 _K	A Balise Group is not detected when indicating safe operation ¹³	10 ⁻¹¹
FM2 _K	Storage of more than 31 bits of data, or data is not delivered in the same order as in the air-gap	10 ⁻¹¹

Table 10: Quantification for the Ebicab 900 system

An SIL level of SIL 4 applies to the Ebicab 900 system.

B3 Maximum number of consecutive ‘ones’

The maximum number of consecutive ‘ones’ allowed by the coding strategy for this system is 12.

¹³ This target is more demanding than the corresponding ERTMS/ETCS requirement defined in SUBSET-036. This target might be based on other criteria than those defined in existing CENELEC standards (because CENELEC standards did not exist when the system was implemented). Specific justifications might be needed.

Annex C, On-board Type 3 Specifics

C1 General

This annex applies to the RSDD system only.

C2 Safety Integrity Requirements

No.	Failure Mode Description	Balise group
		WSF rate [f/h]
FM1 _K	A Balise Group is not detected when indicating safe operation ¹⁴	10 ⁻¹¹
FM2 _K	Storage of more than 31 bits of data, or data is not delivered in the same order as in the air-gap	10 ⁻¹¹

Table 11: Quantification for the RSDD system

An SIL level of SIL 4 applies to the RSDD system.

C3 Maximum number of consecutive ‘ones’

The maximum number of consecutive ‘ones’ allowed by the coding strategy for this system is 6.

¹⁴ This target is more demanding than the corresponding ERTMS/ETCS requirement defined in SUBSET-036. This target might be based on other criteria than those defined in existing CENELEC standards (because CENELEC standards did not exist when the system was implemented). Specific justifications might be needed.

Annex D, On-board Type 4 Specifics

D1 General

This annex applies to the KVB system only.

D2 Safety Integrity Requirements

No.	Failure Mode Description	Balise group
		WSF rate [f/h]
FM1 _K	A Balise Group is not detected when indicating safe operation	10 ⁻⁹
FM2 _K	Storage of more than 31 bits of data, or data is not delivered in the same order as in the air-gap	10 ⁻⁹

Table 12: Quantification for the KVB system

An SIL level of SIL 2 applies to the KVB system.

D3 Maximum number of consecutive ‘ones’

The maximum number of consecutive ‘ones’ allowed by the coding strategy for this system is 6.